

# STEEL STRUCTURES

Practical  
design  
studies

SECOND EDITION



T. J. M a c G i n l e y

E & FN SPON  
An Imprint of Thomson Professional

**Also available as a printed book  
see title verso for ISBN details**

# **Steel Structures**

# **Steel Structures**

Practical design studies

Second edition

**T.J.MacGinley**

Formerly Associate Professor  
Nanyang Technological University  
Singapore

**E & FN SPON**

London and New York

**Published by E & FN Spon, an imprint of Thomson Professional, 2–6  
Boundary Row, London SE1 8HN, UK**

Thomson Science Professional, 2–6 Boundary Row, London SE1 8HN, UK

Thomson Science Professional, Pappelallee 3, 69469 Weinheim, Germany

Thomson Science Professional, 115 Fifth Avenue, New York, NY 10003,  
USA

Thomson Science Professional, ITP-Japan, Kyowa Building, 3F, 2–2–1  
Hirakawacho, Chiyoda-ku, Tokyo 102, Japan

Thomson Science Professional, 102 Dodds Street, South Melbourne,  
Victoria 3205, Australia

Thomson Science Professional, R.Seshadri, 32 Second Main Road, CIT  
East, Madras 600 035, India

First edition 1981

This edition published in the Taylor & Francis e-Library, 2005.

“To purchase your own copy of this or any of Taylor & Francis or Routledge’s collection of thousands of eBooks please go to [www.eBookstore.tandf.co.uk](http://www.eBookstore.tandf.co.uk).”

Second edition 1998

© 1998 G.MacGinley

ISBN 0-203-47428-7 Master e-book ISBN

ISBN 0-203-78252-6 (Adobe eReader Format)

ISBN 0 419 17930 5 (Print Edition)

Apart from any fair dealing for the purposes of research or private study, or criticism or review, as permitted under the UK Copyright Designs and Patents Act, 1988, this publication may not be reproduced, stored, or transmitted, in any form or by any means, without the prior permission in writing of the publishers, or in the case of reprographic reproduction only in accordance with the terms of the licences issued by the Copyright Licensing Agency in the UK, or in accordance with the terms of licences issued by the appropriate Reproduction Rights Organization outside the UK. Enquiries concerning reproduction outside the terms stated here should be sent to the publishers at the London address printed on this page.

The publisher makes no representation, express or implied, with regard to the accuracy of the information contained in this book and cannot accept any legal responsibility or liability for any errors or omissions that may be made.

A catalogue record for this book is available from the British Library

# Contents

Preface	xi
Preface to First Edition	xii
Acknowledgements	xiii
1 Steel structures—structural engineering	1
1.1 Need for and use of structures	1
1.2 Structural materials—types and uses	1
1.3 Types of structures	2
1.3.1 General types of structures	2
1.3.2 Steel structures	3
1.4 Foundations	4
1.5 Structural engineering	4
1.5.1 Scope of structural engineering	4
1.5.2 Structural designer's work	5
1.6 Conceptual design, innovation and planning	7
1.7 Comparative design and optimization	8
1.7.1 General considerations	8
1.7.2 Aims and factors considered in design comparison	8
1.7.3 Specific basis of comparisons for common structures	9
1.8 Load paths, structural idealization and modelling	11
1.8.1 Load paths	11
1.8.2 Structural idealization	12
1.8.3 Modelling	12
1.9 Drawings, specifications and quantities	12
1.9.1 Steelwork drawings	12
1.9.2 Specification	13
1.9.3 Quantities	15
1.10 Fabrication	15
1.11 Transport and erection	16
2 Structural steel design	17
2.1 Design theories	17
2.1.1 Development of design	17

2.1.2	Design from experience	17
2.1.3	Elastic theory	17
2.1.4	Plastic theory	18
2.1.5	Limit state theory and design codes	19
2.2	Limit states and design basis	20
2.3	Loads, actions and partial safety factors	20
2.3.1	Loads	20
2.3.2	Load factors/partial safety factors and design loads	21
2.4	Structural steels—partial safety factors for materials	21
2.5	Design methods from codes—ultimate limit state	21
2.5.1	Design methods from BS 5950	21
2.5.2	Analysis of structures—Eurocode 3	23
2.5.3	Member and joint design	23
2.6	Stability limit state	24
2.7	Design for accidental damage	24
2.7.1	Progressive collapse and robustness	24
2.7.2	Building Regulations 1991	25
2.7.3	BS 5950 requirements for structural integrity	25
2.8	Serviceability limit states	26
2.8.1	Deflection limits	26
2.8.2	Vibration	26
2.9	Design considerations	26
2.9.1	Fatigue	26
2.9.2	Brittle fracture	27
2.9.3	Corrosion protection	28
2.9.4	Fire protection	28
3	Preliminary design	31
3.1	General considerations	31
3.2	Need for and scope of preliminary design methods	31
3.3	Design concept, modelling and load estimation	31
3.3.1	Design concept	31
3.3.2	Modelling	32
3.3.3	Load estimation	32
3.4	Analysis	32
3.4.1	Statically determinate structures	32
3.4.2	Statically indeterminate structures	35
3.5	Element design	38

3.5.1	General comments	38
3.5.2	Ties and struts	39
3.5.3	Beams and girders	40
3.5.4	Beam-columns	41
3.5.5	Members in portal frames	42
3.6	Examples	43
3.6.1	Ribbed dome structure	43
3.6.2	Two pinned portal—plastic design	45
4	Single-storey, one-way-spanning buildings	48
4.1	Types of structures	48
4.2	Pinned-base portal—plastic design	48
4.2.1	Specification and framing plans	48
4.2.2	Dead and imposed loads	49
4.2.3	Wind loads	50
4.2.4	Design load cases	52
4.2.5	Plastic analysis and design	52
4.2.6	Dead and wind loads	54
4.2.7	Plastic design checks	55
4.2.8	Rafter under wind uplift	59
4.2.9	Portal joints	60
4.2.10	Serviceability check	62
4.3	Built-up tapered member portal	63
4.3.1	General comments	63
4.3.2	Design process	63
4.4	Two-pinned arch	63
4.4.1	General considerations	63
4.4.2	Specification	64
4.4.3	Loading	65
4.4.4	Analysis	65
4.4.5	Design	65
4.4.6	Construction	67
4.4.7	Lattice arch	67
5	Multistorey buildings	72
5.1	Outline of designs covered	72
5.1.1	Aims of study	72
5.1.2	Design to BS 5950	72
5.2	Building and loads	72

5.2.1	Specification	72
5.2.2	Loads	73
5.2.3	Materials	74
5.3	Simple design centre frame	75
5.3.1	Slabs	75
5.3.2	Roof beam	75
5.3.3	Floor beam	75
5.3.4	Outer column—upper length 7–10–13	75
5.3.5	Outer column—lower length 1–4–7	75
5.3.6	Centre column—upper length 8–11–14	76
5.3.7	Centre column—lower length 2–5–8	76
5.3.8	Joint design	77
5.3.9	Baseplate—centre column	77
5.4	Braced rigid elastic design	78
5.4.1	Computer analysis	78
5.4.2	Beam design	78
5.4.3	Column design	81
5.4.4	Joint design	82
5.5	Braced rigid plastic design	83
5.5.1	Design procedure	83
5.5.2	Design loads and moments	84
5.5.3	Frame design	85
5.6	Semirigid design	90
5.6.1	Code requirements	90
5.6.2	Joint types and performance	91
5.6.3	Frame analysis	91
5.6.4	Frame design	94
5.7	Summary of designs	100
6	Floor systems	101
6.1	Functions of floor systems	101
6.2	Layouts and framing systems	101
6.3	Types of floor construction	102
6.4	Composite floor slabs	103
6.4.1	General comments	103
6.4.2	Design procedure	103
6.5	Composite beam design	104
6.5.1	Design basis	104



6.5.2	Effective section	105
6.5.3	Plastic moment capacity	105
6.5.4	Construction	106
6.5.5	Continuous beam analysis	106
6.5.6	Design of members	106
6.5.7	Shear connectors	107
6.5.8	Longitudinal shear	108
6.5.9	Deflection	109
6.6	Simply supported composite beam	109
6.6.1	Specification	109
6.6.2	Moment capacity	110
6.6.3	Shear	110
6.6.4	Shear connectors	110
6.6.5	Longitudinal shear	110
6.6.6	Deflection	110
6.7	Continuous composite beam	111
6.7.1	Specification	111
6.7.2	Floor loads	112
6.7.3	Elastic analysis and redistribution	113
6.7.4	Section design checks	116
6.7.5	Shear connectors	118
6.7.6	Longitudinal shear	119
6.7.7	Deflection	120
7	Tall buildings	122
7.1	General considerations	122
7.2	Structural design considerations	123
7.3	Structural systems	123
7.3.1	All-steel braced structure	123
7.3.2	Rigid frame and mixed systems	124
7.3.3	All-steel outrigger and belt truss system	125
7.3.4	Composite structures	126
7.3.5	Suspended structures	127
7.3.6	Tube structures	128
7.3.7	SWMB structures	129
7.4	Construction details	129
7.4.1	Roofs and floors	129
7.4.2	Walls	131

7.4.3	Steel members	131
7.5	Multistorey building—preliminary design	131
7.5.1	Specification	131
7.5.2	Dead and imposed loads	132
7.5.3	Beam loads and design	133
7.5.4	Design of perimeter column PC1	136
7.5.5	Braced core wall—vertical loads	139
7.5.6	Wind loads	140
7.5.7	Stability, foundations and bracing	144
8	Wide-span buildings	146
8.1	Types and characteristics	146
8.2	Tie-stayed roof—preliminary design	147
8.2.1	Specification	147
8.2.2	Preliminary design	149
8.2.3	Stability and wind load	153
8.3	Space decks	155
8.3.1	Two-way spanning roofs	155
8.3.2	Space decks	157
8.3.3	Space deck analysis and design	157
8.4	Preliminary design for a space deck	158
8.4.1	Specification	158
8.4.2	Arrangement of space deck	158
8.4.3	Approximate analysis and design	158
8.4.4	Computer analysis	159
8.4.5	Computer results	162
8.4.6	Member design	162
8.5	Framed domes	163
8.5.1	Types	163
8.5.2	Dome construction	164
8.5.3	Loading	165
8.5.4	Analysis	166
8.5.5	Stability	166
8.6	Schwedler dome	166
8.6.1	Specification	166
8.6.2	Loading for statical analysis	167
8.6.3	Statical analysis	167
8.6.4	Member design	171

8.6.5	Membrane analysis	172
8.7	Retractable roof stadium	172
8.7.1	Introduction	172
8.7.2	Proposed structure	173
8.7.3	Preliminary section sizes	174
8.7.4	Problems in design and operation	175
	Bibliography	177
	Index	179

# Preface

The main purpose of the second edition is again to present principles, relevant considerations and sample designs for some of the major types of steel-framed buildings. All buildings can be framed in different ways with different types of joints and analysed using different methods. Member design for ultimate conditions is specified. Projects are selected to show alternative designs for the same structure.

Designs are now to conform to limit state theory—the British steel code and the new Eurocode. Design principles are set out briefly and designs made to the British code only. Reference is made to the Eurocode in one special case. Many more design calculations and checks are required for the limit state code than for the previous elastic code and thus not all load cases or detailed checks can be carried out for every design project. However, further necessary design work is indicated in these cases.

Though computer methods, mainly for analysis, but also increasingly used for member and connection design are now the design office procedural norm, approximate, manual methods are still of great importance. These are required mainly to obtain sections for computer analysis and to check final designs.

The book, as in the case of the first edition, is aimed at final year students, candidates on master's degree courses in structural engineering and young engineers in industry. Fundamental knowledge of the methods of structural analysis and design from a basic design course is assumed.

# Preface to the First Edition

The purpose of the book is to present the principles and practice of design for some of the main modern structures. It is intended for final year degree students to show the application of structural engineering theory and so assist them to gain an appreciation of the problems involved in the design process in the limited time available in college. In such a presentation many topics cannot be covered in any great detail.

Design is a decision-making process where engineering judgement based on experience, theoretical knowledge, comparative design studies etc., is used to arrive at the best solution for a given situation. The material in the book covers the following:

- (a) discussion of conceptual design and planning;
- (b) presentation of the principles and procedures for the various methods of analysis and design;
- (c) detailed analysis and design for selected structures. Preliminary design studies are made in other cases where the full treatment of the problem is beyond the scope of this book.

In detailed design, the results are presented in the form of sketches showing framing plans, member sizes and constructional details.

Although the book is primarily concerned with the design of steel structures, important factors affecting both the overall design and detail required are discussed briefly. These include the choice of materials, type of foundations used, methods of jointing, the fabrication process and erection methods. Other design considerations such as fatigue, brittle fracture, fire resistance and corrosion protection are also noted.

The use of computers in design is now of increasing importance. Where required, computer programs are used in the book for analysis. While examples of computer-aided design have not been included, a project on this topic is listed at the end of the book. It is felt that the student must thoroughly understand design principles before using design programs.

In college, the student is instructed through formal lectures backed by reading from textbooks and journals and by consultation with staff and fellow students. The acquisition of knowledge and the exchange of ideas help him to develop his expertise and judgement and to make sound decisions. However, the most important part of the learning process is the carrying out of practical design work where the students are given selected coursework exercises which cover the stages in the design process. Such exercises have been included at the end of most chapters. These, generally, consist of making designs for given structures including framing plans, computer analysis, design and details drawings.

In many first degree courses, the student is also required to undertake a project for which he may choose a topic from the structural engineering field. This gives him the opportunity to make a study in a particular area of interest in greater depth than would be possible through the normal lectures. Some suggestions for projects are given at the end of the book. These may be classified as follows:

- (a) comparative design studies;
- (b) computer-aided design projects;
- (c) construction and testing of structural models and presentation of results in report form.

The intention of the book is to help equip the young engineer for his role in structural engineering in industry. It is important to foster interest in structural engineering in industry. It is important to foster interest in structural design where this is shown by a student. It is hoped that this book will go some way towards this goal.

# Acknowledgements

Extracts from British Standard BS 5950: Parts 1, 3 and 4 are reproduced by permission of the British Standards Institution, 2 Park Street, London W1A 2BS, from whom copies can be obtained.

# CHAPTER 1

## Steel structures—structural engineering

### 1.1

#### NEED FOR AND USE OF STRUCTURES

Structures are one of mankind's basic needs next to food and clothing, and are a hallmark of civilization. Man's structural endeavours to protect himself from the elements and from his own kind, to bridge streams, to enhance a ruling class and for religious purposes go back to the dawn of mankind. Fundamentally, structures are needed for the following purposes:

- to enclose space for environmental control;
- to support people, equipment, materials etc. at required locations in space;
- to contain and retain materials;
- to span land gaps for transport of people, equipment etc.

The prime purpose of structures is to carry loads and transfer them to the ground.

Structures may be classified according to use and need. A general classification is:

- residential—houses, apartments, hotels;
- commercial—offices, banks, department stores, shopping centres;
- institutional—schools, universities, hospitals, gaols;
- exhibition—churches, theatres, museums, art galleries, leisure centres, sports stadia, etc.;
- industrial—factories, warehouses, power stations, steelworks, aircraft hangers etc.

Other important engineering structures are:

- bridges—truss, girder, arch, cable suspended, suspension;
- towers—water towers, pylons, lighting towers etc.;
- special structures—offshore structures, car parks, radio telescopes, mine headframes etc.

Each of the structures listed above can be constructed using a variety of materials, structural forms or systems. Materials are discussed first and then a general classification of structures is set out, followed by one of steel structures. **Though the subject is steel structures, steel is not used in isolation from other materials. All steel structures must rest on concrete foundations and concrete shear walls are commonly used to stabilize multistorey buildings.**

### 1.2

#### STRUCTURAL MATERIALS—TYPES AND USES

From earliest times, naturally occurring materials such as timber, stone and fibres were used structurally. Then followed brickmaking, rope-making, glass and metalwork. From these early beginnings the modern materials manufacturing industries developed.

The principal modern building materials are masonry, concrete (mass, reinforced and prestressed), structural steel in rolled and fabricated sections and timber. All materials listed have particular advantages in given situations, and construction of a particular building type can be in various materials, e.g. a multistorey building can be loadbearing masonry, concrete shear wall or frame or steel frame. One duty of the designer is to find the best solution which takes account of all requirements — economic, aesthetic and utilitarian.

The principal uses, types of construction and advantages of the main structural materials are as follows.

- Masonry—loadbearing walls or columns in compression and walls taking in-plane or transverse loads. Construction is very durable, fire resistant and aesthetically pleasing. Building height is moderate, say to 20 storeys.
- Concrete—framed or shear wall construction in reinforced concrete is very durable and fire resistant and is used for the tallest buildings. Concrete, reinforced or prestressed, is used for floor construction in all buildings, and concrete foundations are required for all buildings.
- Structural steel—loadbearing frames in buildings, where the main advantages are strength and speed of erection. Steel requires protection from corrosion and fire. Claddings and division walls of other materials and concrete foundations are required. Steel is used in conjunction with concrete in composite and combined frame and shear wall construction.

Structural steels are alloys of iron, with carefully controlled amounts of carbon and various other metals such as manganese, chromium, aluminium, vanadium, molybdenum, niobium and copper. The carbon content is less than 0.25%, manganese less than 1.5% and the other elements are in trace amounts. The alloying elements control grain size and hence steel properties, giving high strengths, increased ductility and

**Table 1.1** Strengths of steels used in structures

Steel type and use	Yield stress (N/mm <sup>2</sup> )
Grade 43—structural shapes	275
Grade 50—structural shapes	355
Quenched and self-tempering	500
Quenched tempered-plates	690
Alloy bars—tension members	1030
High carbon hard-drawn wire for cables	1700

fracture toughness. The inclusion of copper gives the corrosion resistant steel Cor-ten. High-carbon steel is used to manufacture hard drawn wires for cables and tendons.

The production processes such as cooling rates, quenching and tempering, rolling and forming also have an important effect on the micro structure, giving small grain size which improves steel properties. The modern steels have much improved weldability. Sound full-strength welds free from defects in the thickest sections can be guaranteed.

A comparison of the steels used in various forms in structures is given in Table 1.1. The properties of hot-rolled structural steels are given Chapter 2 (Table 2.3).

Structural steels are hot-rolled into shapes such as universal beams and columns. The maximum size of universal column in the UK is 356×406 UC, 634 kg/m, with 77 mm-thick flanges. Trade-ARBED in Luxembourg roll a section 360×401 WTM, 1299 kg/m, with 140 mm-thick flanges. The heavy rolled columns are useful in high-rise buildings where large loads must be carried. Heavy built-up H, I and box sections made from plates and lattice members are needed for columns, transfer girders, crane and bridge girders, etc. At the other end of the scale, light weight cold-rolled purlins are used for roofing industrial buildings. Finally, wire, rope and high-strength alloy steel bars are required for cable-suspended and cable-girder roofs and suspended floors in multistorey buildings.

## 1.3

### TYPES OF STRUCTURES

#### 1.3.1

##### General types of structures

The structural engineer adopts a classification for structures based on the way the structure resists loads, as follows.

1. Gravity masonry structures—loadbearing walls resist loads transmitted to them by floor slabs. Stability depends on gravity loads.
2. Framed structures—a steel or concrete skeleton collects loads from plate elements and delivers them to the foundations.
3. Shell structures—a curved surface covers space and carries loads.
4. Tension structures—cables span between anchor structures carrying membranes.
5. Pneumatic structures—a membrane sealed to the ground is supported by internal air pressure.



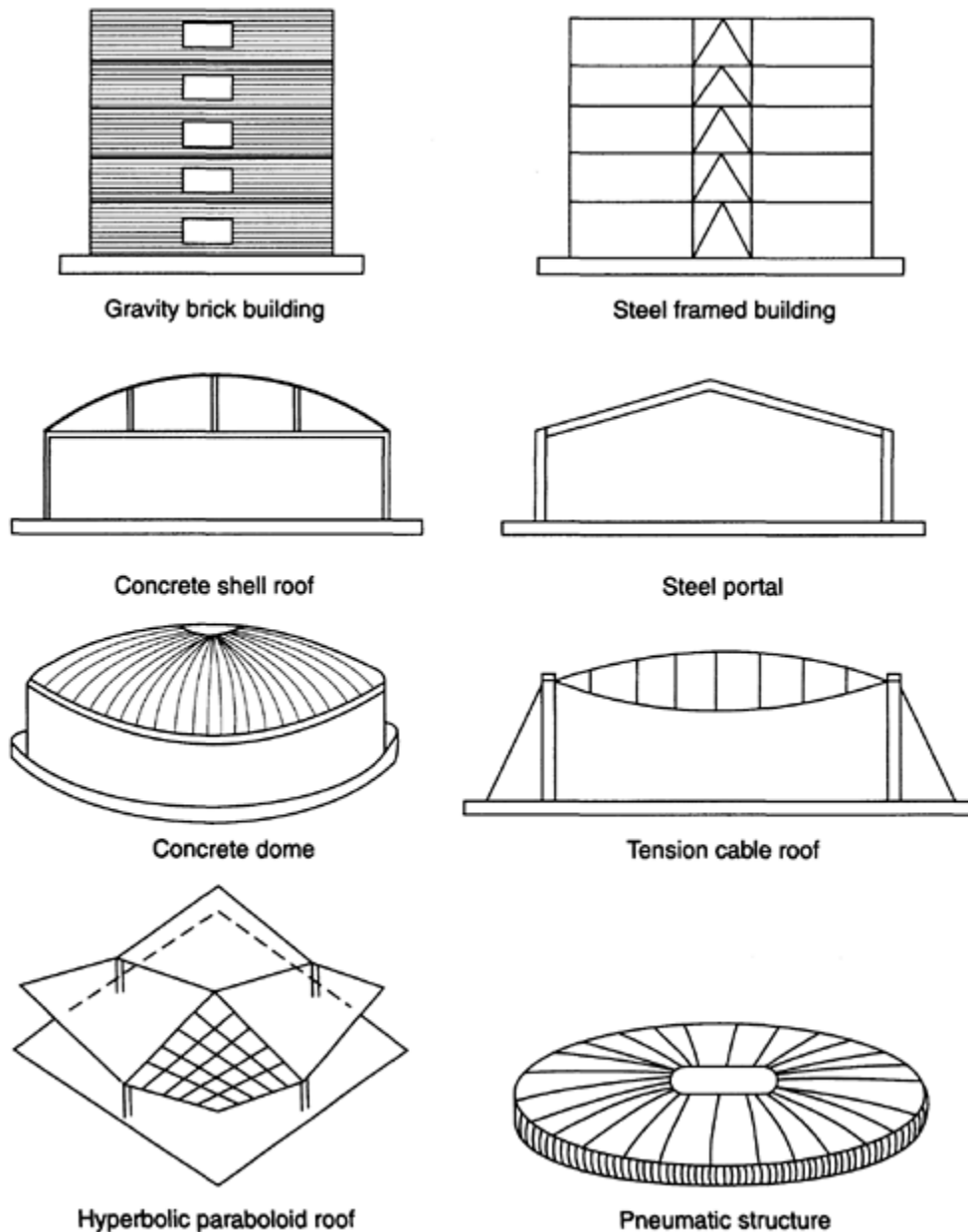

Fig. 1.1 General types of structures.

Examples of the above structures are shown in [Figure 1.1](#)

### 1.3.2 Steel structures

Steel-framed structures may be further classified into the following types:

1. single-storey, single- or multibay structures which may be of truss or stanchion frames or rigid frame of solid or lattice members;
2. multistorey, single- or multibay structures of braced or rigid frame construction—many spectacular systems have been developed;
3. space structures (space decks, domes, towers etc.)—space decks and domes (except the Schwedler dome) are redundant structures, while towers may be statically determinate space structures;
4. tension structures and cable-supported roof structures;

## 5. stressed skin structures, where the cladding stabilizes the structure.

As noted above, combinations with concrete are structurally important in many buildings. Illustrations of some of the types of framed steel structures are shown in Figure 1.2. Braced and rigid frame and truss roof and space deck construction are shown in the figure for comparison. Only framed structures are dealt with in the book. Shell types, e.g. tanks, tension structures and stressed skin structures are not considered.

For the framed structures the main elements are the beam, column, tie and lattice member. Beams and columns can be rolled or built-up I, H or box. Detailed designs including idealization, load estimation, analysis and section design are given for selected structures.

## 1.4 FOUNDATIONS

Foundations transfer the loads from the building structure to the ground. Building loads can be vertical or horizontal and cause overturning and the foundation must resist bearing and uplift loads. The correct choice and design of foundations is essential in steel design to ensure that assumptions made for frame design are achieved in practice. If movement of a foundation should occur and has not been allowed for in design, it can lead to structural failure and damage to finishes in a building. The type of foundation to be used depends on the ground conditions and the type of structure adopted

The main types of foundations are set out and discussed briefly, as follows.

1. Direct bearing on rock or soil. The size must be sufficient to ensure that the safe bearing pressure is not exceeded. The amount of overall settlement may need to be limited in some cases, and for separate bases differential settlement can be important. A classification is as follows:
  - pad or spread footing used under individual columns;
  - special footings such as combined, balanced or tied bases and special shaped bases;
  - strip footings used under walls or a row of columns;
  - raft or mat foundations where a large slab in flat or rubbed construction supports the complete building;
  - basement or cellular raft foundations; this type may be in one or more storeys and form an underground extension to the building that often serves as a carpark.
2. Piled foundations, where piles either carry loads through soft soil to bear on rock below or by friction between piles and earth. Types of piles used vary from precast driven piles and cast-in-place piles to large deep cylinder piles. All of the above types of foundations can be supported on piles where the foundation forms the pile cap.

Foundations are invariably constructed in concrete. Design is covered in specialist books. Some types of foundations for steel-framed buildings are shown in Figure 1.3. Where appropriate, comments on foundation design are given in worked examples.

## 1.5 STRUCTURAL ENGINEERING

### 1.5.1 Scope of structural engineering

Structural engineering covers the conception, planning, design, drawings and construction for all structures. Professional engineers from a number of disciplines are involved and work as a team on any given project under the overall control of the architect for a building structure. On engineering structures such as bridges or powerstations, an engineer is in charge.

Lest it is thought that the structural engineer's work is mechanical or routine in nature, it is useful to consider his/her position in building construction where the parties involved are:

- the client (or owning organization), who has a need for a given building and will finance the project;
- the architect, who produces proposals in the form of building plans and models (or a computer simulation) to meet the client's requirements, who controls the project and who engages consultants to bring the proposals into being;
- consultants (structural, mechanical, electrical, heating and ventilating etc.), who carry out the detail design, prepare working drawings and tender documents and supervise construction;

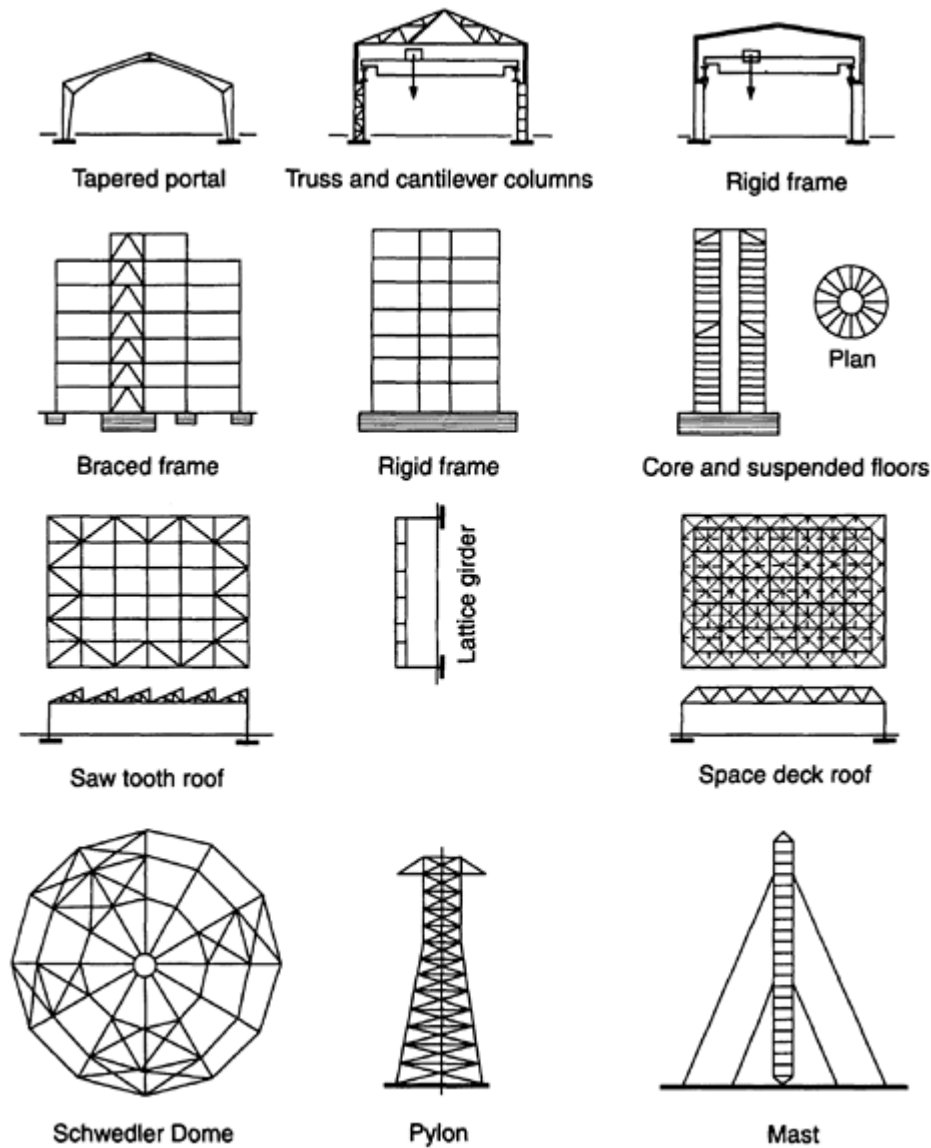

**Fig. 1.2** Examples of steel-framed structures.

- contractors, who carry out fabrication and erection of the structural framework, floors, walls, finishes and installation of equipment and services.

The structural engineer works as a member of a team and to operate successfully requires flair, sound knowledge and judgement, experience and the ability to exercise great care. His or her role may be summarized as planning, design preparation of drawings and tender documents and supervision of construction. He/she makes decisions about materials, structural form and design methods to be used. He/she recommends acceptance of tenders, inspects, supervises and approves fabrication and construction. He/she has an overall responsibility for safety and must ensure that the consequences of failure due to accidental causes are limited in extent.

The designer's work, which is covered partially in this book, is one part of the structural engineer's work.

### 1.5.2 Structural designer's work

The aim of the structural designer is to produce the design and drawings for a safe and economical structure that fulfils its intended purpose. The steps in the design process are as follows.

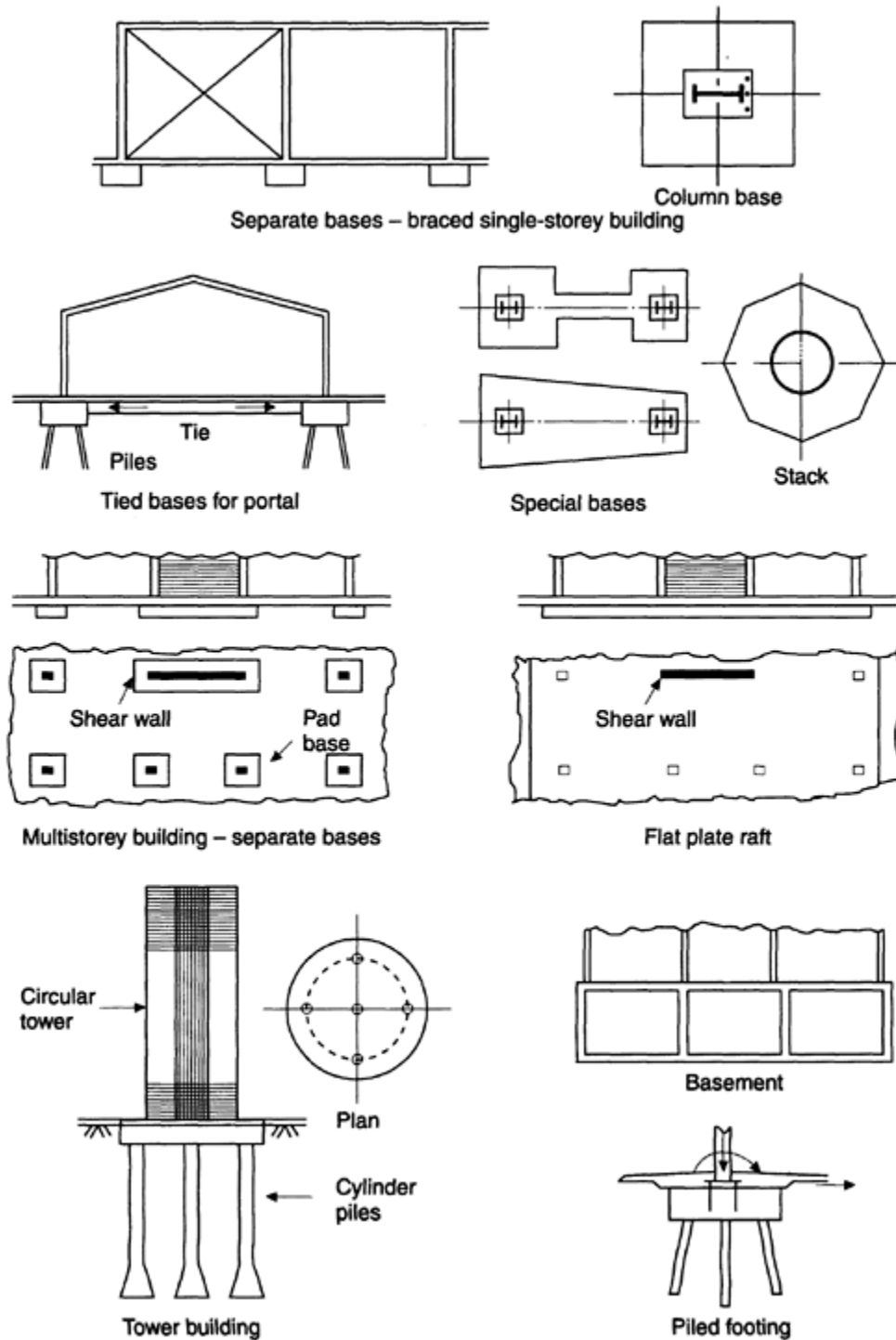

Fig. 1.3 Types of foundations.

1. Conceptual design and planning. This involves selecting the most economical structural form and materials to be used. Preliminary designs are often necessary to enable comparisons to be made. Preliminary design methods are discussed in [Chapter 3](#).
2. Detailed design for a given type and arrangement of structure, which includes:
  - idealization of the structure for analysis and design;
  - estimation of loading;
  - analysis for the various load cases and combinations of loads and identification of the most severe design actions;

- design of the foundations, structural frames, elements and connections;
- preparation of the final arrangement and detail drawings.

The materials list, bill of quantities and specification covering welding, fabrication erection corrosion protection and fire protection may then be prepared. Finally the estimates and tender documents can be finalized for submission to contractors.

The structural designer uses his/her knowledge of structural mechanics and design, materials, geotechnics and codes of practice and combines this with his/her practical experience to produce a satisfactory design. He/she takes advice from specialists, makes use of codes, design aids, handbooks and computer software to help him/her in making decisions and to carry out complex analysis and design calculations.

## 1.6

### CONCEPTUAL DESIGN, INNOVATION AND PLANNING

Conceptual design in the structural engineering sense is the function of choosing a suitable form or system or framing arrangement to bring the architectural solution into being. The building layout, limits and parameters have often been determined solely by the architect. In such cases the structural engineer may not be able to select the optimum structural solution. Ideally, conceptual design should result from a team effort, where architect, structural engineer and service engineers contribute to the final solution. Modern architectural practices take this multidisciplinary approach.

The architectural decisions are based on functional, aesthetic, environmental and economic considerations. Any of these factors may control in a given case. For example, for an industrial plant it is the functional requirement, whereas for an exhibition building it is the aesthetic aspect. Financial control is always of paramount importance and cost over-runs lead to many legal and other problems.

Novelty and innovation are always desirable and we seem to strive after these goals. Architects, engineers and builders always push existing forms of construction to the limits possible with materials available and within the state of knowledge at the time. Structural failures determine when limits are reached and so modifications are made and new ideas developed. Often it is not a new solution that is required, but the correct choice and use of a well proven existing structural system that gives the best answer. The engineer continually seeks new and improved methods of analysis, design and construction, and the materials scientist continually seeks to improve material properties and protection systems through research and development. These advances lead to safer and more economical structures. Much of recent structural research has centred on the use of computers in all aspects of the work from architectural and structural modelling and design for construction and building finishing control.

The following are instances of recent structural engineering innovation:

1. analysis—elastic matrix and finite element analysis, second order analysis, cable net analysis, plastic analysis;
2. design—plastic design, limit state design, computer-aided design, structural optimization;
3. construction—space decks, geodesic domes, tension structures, box girder bridges, high-rise tube buildings etc.

Planning may be described as the practical expression of conceptual design. The various proposals must be translated from ideas and sketches into drawings consisting of plans and elevations to show the layout and functions and perspective views to give a realistic impression of the finished concept. Computer drafting software is now available to make this work much quicker than the older manual methods. Three-dimensional computer simulation with views possible from all directions gives great assistance in the decision-making process. A scale model of the complete project is often made to show clearly the finished form. The preparation and presentation of planning proposals are very important because the final approval for a scheme often rests with non-technical people such as city councillors or financiers.

The engineer must also consider construction in any of the major materials—masonry, concrete, steel or timber, or again some combination of these materials for his/her structures, and then make the appropriate selection. A list of factors that need to be considered at the conceptual and planning stage would include:

1. location of the structure and environmental conditions;
2. site and foundation conditions;
3. weather conditions likely during construction;
4. availability of materials;
5. location and reputation of fabrication industry;
6. transport of materials and fabricated elements to site;
7. availability and quality of labour for construction;
8. degree of supervision needed for construction;

9. measures needed to give protection against corrosion and fire;
10. likelihood of damage or failure due to fatigue or brittle fracture;
11. possibility of accidental damage;
12. maintenance required after completion;
13. possibility of demolition in the future.

The final decision on the form and type of structure and construction method depends on many factors and will often be taken on grounds other than cost, though cost often remains the most important.

## 1.7 COMPARATIVE DESIGN AND OPTIMIZATION

### 1.7.1 General considerations

Preliminary designs to enable comparisons and appraisals to be made will often be necessary during the planning stage in order to establish which of the possible structural solutions is the most economical. Information from the site survey is essential because foundation design will affect the type of superstructure selected as well as the overall cost.

Arrangement drawings showing the overall structural system are made for the various proposals. Then preliminary analyses and designs are carried out to establish foundation sizes, member sizes and weights so that costs of materials, fabrication, construction and finishes can be estimated. Fire and corrosion protection and maintenance costs must also be considered. However, it is often difficult to get true comparative costs and contractors are reluctant to give costs at the planning stage. Preliminary design methods are given in the book and worked examples have been selected to show design comparisons using different structural systems or design methods.

By optimization is meant the use of mathematical techniques to obtain the most economical design for a given structure. The aim is usually to determine the topology of the structure, arrangement of floors, spacing of columns or frames or member sizes to give the minimum weight of steel or minimum cost. Though much research has been carried out and sophisticated software written for specific cases, the technique is not of general practical use at present. Many important factors cannot be satisfactorily taken into account.

The design of individual elements may be optimized, e.g. plate girders or trusses. However, with optimum designs the depths are often some 50% greater than those normally adopted and the effect of this on the total building cost should be considered. Again, in optimizing member costs it is essential to rationalize sizes, even if this may lead to some oversized items. Floor layouts and column spacings should be regular and as a consequence, fabrication and erection will be simplified and cost reduced.

### 1.7.2 Aims and factors considered in design comparison

The aim of the design comparison is to enable the designer to ascertain the most economical solution that meets the requirements for the given structure. All factors must be taken into consideration. A misleading result can arise if the comparison is made on a restricted basis. **Factors to be taken into account include:**

1. materials to be used;
2. arrangement and structural system and flooring system to be adopted;
3. fabrication and type of jointing;
4. method of erection of the framework to be used;
5. type of construction for floor, walls, cladding and finishes;
6. installation of ventilating/heating plant, lifts, water supply, power etc.;
7. Corrosion protection required;
8. Fire protection required;
9. Operating and maintenance costs.

Aesthetic considerations are important in many cases and the choice of design may not always be based on cost alone.

Most structures can be designed in a variety of ways. The possible alternatives that may be used include:

1. the different methods of framing that will achieve the same structural solution;
2. selection of spacing for frames and columns;
3. flooring system to be used, e.g. *in situ* concrete, precast concrete or profile steel sheeting
4. the various methods that may be used to stabilize the building and provide resistance to horizontal loading;
5. the different design methods that may be applied to the same structural form, e.g. simple design or semirigid design, or rigid design using either elastic or plastic theory.
6. design in different materials, e.g. mild steel or high strength steels. The weight saving may be offset by the higher cost of the stronger material.

It should be noted that often no one solution for a given structure ever appears to dominate to the exclusion of all other alternatives. Though the rigid pinned base portal has almost entirely replaced the truss and stanchion frame for single-bay buildings, lattice girder roofs are used in many single-storey multibay buildings.

### 1.7.3

#### Specific basis of comparisons for common structures

In the following sections a classification is given on which design comparisons for some general purpose structures may be made. More detailed design comparisons are given in later chapters.

(a)

*Single-storey, single-bay buildings*

For a given plan size the designer can make the following choices.

#### (i) Type of building and design method (Figure 1.4(a))

The alternatives are:

1. truss and stanchion frame with cantilever columns on knee-braces with pinned or fixed bases using simple design;
2. three-pinned portal of I-section or lattice construction using simple design;
3. rigid portal with pinned or fixed base constructed in:
  - rolled I—or hollow section designed using elastic or plastic theory;
  - built-up I-tapered or haunched sections designed using elastic theory.
  - lattice construction designed using elastic theory.

The design may be fully welded or with rigid joints made using high-strength bolts.

#### (ii) Design variables

The basic variable is column spacing which governs the size of purlins, sheeting rails, main frame members and foundations. Designs may be made with various column spacings to determine which gives the most economical results. Various roof shapes are possible such as flat, ridge, sawtooth, monitor or mansard (Figure 1.4 (a)). The roof slope is a further variable; the present practice is to use flatter slopes. In the longitudinal direction these buildings are in braced simple design. The gable ends are normally simple design.

(b)

*Single-storey, multibay buildings*

Three common types of single-storey, multibay buildings are the lattice girder roof, multibay portal and cable suspended roof (Figure 1.4 (b)). The comments from (a) above apply. For wide-span buildings the sawtooth or space deck roof shown in Figure 1.2 is used.

(c)

*Multistorey buildings*

Many different systems are used and many parameters can be varied in design. Some important aspects of the problem are as follows.

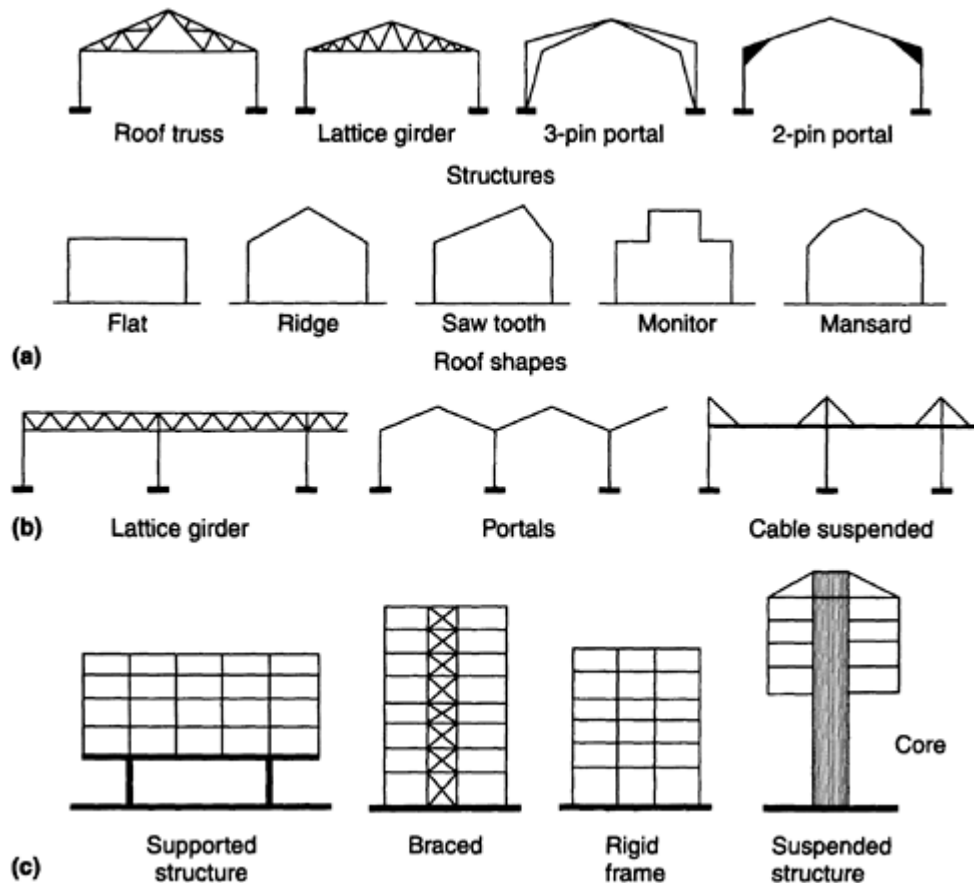

**Fig. 1.4** Comparison of designs for various structures: (a) single-storey, single-bay structures; (b) single-storey, multibay structures; (c) multistorey structures.

#### (i) Overall framing

The column spacing can be varied in both directions. The locations of the liftshaft/staircase can be varied. Not all columns may be continuous throughout the building height. Plate girders can be used to carry upper columns over clear areas. Economy can be achieved if the bottom storey columns are set in, allowing girders to cantilever out. All columns can carry load, or the outer ends of floor beams can be suspended from an umbrella girder supported by the core (Figure 1.2).

#### (ii) Flooring

The type of flooring and arrangement of floor framing affect the overall design. The main types of flooring used are cast-*in situ* concrete in one- or two-way spanning slabs or precast one-way floor slabs. The cast-*in situ* slabs can be constructed to act compositively with the steel floor beams. Flat slab construction has also been used with steel columns where a special steel shear head has been designed.

#### (iii) Stability

Various systems or framing arrangements can be used to stabilize multistorey buildings and resist horizontal loads. The building may be braced in both directions, rigid one way and braced the other or rigid in both directions. Alternatively, concrete shear walls or liftshafts can be used to provide stability. Tube construction is used for very tall buildings (Chapter 7).

#### (iv) Design method

For a given framing system various design methods can be used. The methods given in BS 5950 are simple, semirigid or rigid design. Rigid design can be carried out using either elastic or plastic methods. More accurate methods taking secondary effects into account are possible with elastic analysis. Analysis and design methods are discussed more fully in the next chapter.

#### (v) Fire protection



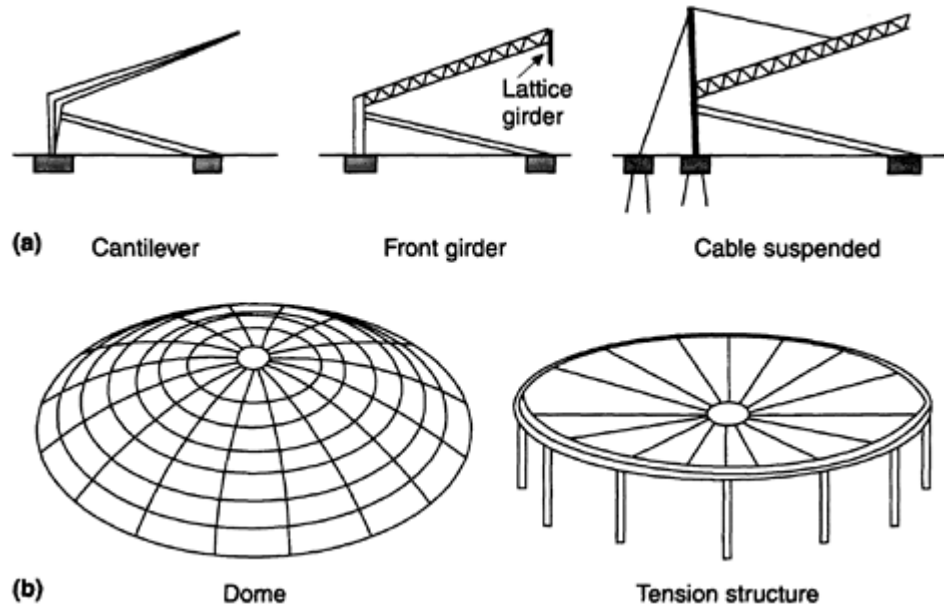

Fig. 1.5 Special purpose structures: (a) grandstand structures; (b) covered areas.

This is necessary for all steel-framed buildings, and solid casing of beams and columns may be taken into account in design. However, lightweight hollow or sprayed-on casing is generally used in modern practice. Methods have been developed for assessment of fire resistance for steel members.

#### (vi) Foundations

Types of foundations used for steel-framed buildings were set out above. The type selected for prevailing soil conditions can affect the choice of superstructure. One common case is to use pinned bases in poor soil conditions because fixity would be expensive to achieve. Again, where provision must be made for differential settlement, buildings of simple design perform better than those of rigid design. If a monolithic raft or basement foundation is provided, the super structure can be designed independently of the foundation.

(d)

#### *Special purpose structures*

In some structures there may be two or more entirely different ways of framing or forming the structure while complying with all requirements for the finished project. One such structure is the sports grandstand. Three solutions for the structure are as follows.

1. Cantilever construction is used throughout.
2. End columns support a lattice girder which carries the front of the roof.
3. The roof is suspended on cables.

Another example is the dome and circular suspended roof structure. (Figure 1.5).

## 1.8

### LOAD PATHS, STRUCTURAL IDEALIZATION AND MODELLING

#### 1.8.1

##### Load paths

Loads are applied to surfaces, along members and to points along members. Surfaces, that is roof and floor slabs and walls, transfer loads to members in skeletal structures. Transfer of load from surface to member and member to member, such as slab to beam, wall to column, beam to beam and beam to column to foundation, are the load paths through the structure. Each individual slab, member or frame must be strong enough to carry its loads. Members and frames must be spaced and arranged

to carry their loads in the most efficient manner. Standard framing arrangements have been developed for all types of buildings.

### 1.8.2 Structural idealization

Structures support loads and enclose space and are of three-dimensional construction. Idealization means breaking the complete structure down into single elements (beams, columns, trusses, braced or rigid frames) for which loads carried are estimated and analysis and design made. It is rarely possible to consider the three-dimensional structure in its entirety. Examples of idealization are as follows.

1. Three-dimensional structures are treated as a series of plane frames in each direction. The division is made by vertical planes. For example, a multistorey building (Figure 1.6 (a)) readily divides into transverse rigid frames and longitudinal braced frames. The tower structure in Figure 1.6(b) could be analysed, using software, as a space frame. Alternatively it is more commonly treated as a series of plane frames to resist horizontal loads and torsion due to wind.
2. The structure is divided into vertically separated parts by horizontal planes into say, roof, walls, and foundations. These parts are designed separately. The reactions from one part are applied as loads to the next part. The horizontal division of a truss and stanchion frame is shown in Figure 1.6(c), while a portal frame is treated as a complete unit. A domed-roof stadium similarly divided is shown in Figure 1.6(d). The domed roof may be designed as a three-dimensional unit or, in the case of specially framed domes, as a series of arched ribs.

### 1.8.3 Modelling

Another idealization method is modelling for analysis. In this case the structure is changed so that the analysis of a different form of structure that is more convenient to carry out can be made. This often means modelling the structure for analysis using a plane frame program. Two examples shown in Figure 1.7(a) and (b) are:

- a ribbed deck idealized as a grid;
- connected concrete shear walls modelled as a plane frame.

These examples can also be modelled for more accurate finite element analysis.

The modelling problem with steel structures also often includes composite action of steel and concrete elements. Examples are as follows.

- *In situ* concrete slab and steel beams in a steel rigid frame. For analysis the elastic transformed section can be used for the composite beams (Figure 1.7(c)). Design is based on plastic theory.
- Concrete shear wall in a rigid steel frame (Figure 1.7(d)). If there is compression over the whole section the slab can be transformed into equivalent steel. If compression occurs over part of the section, use the transformed section in bending including reinforcement in tension. The shear wall is to be connected to steel sections.
- A three-dimensional steel rigid frame building with concrete core (Figure 1.7(e)). This can be modelled for plane frame analysis for horizontal wind loads by linking frames and replacing the shear wall by stiff vertical and horizontal members. Alternatively the structure can be analysed as a space frame.

Great care is needed in interpreting results for design. Finite element analysis will give more accurate results.

## 1.9 DRAWINGS, SPECIFICATIONS AND QUANTITIES

### 1.9.1 Steelwork drawings

Steelwork drawings show the detail for fabrication and arrangement of the structure for erection. They are also used for taking off the materials list and preparing the bill of quantities and estimates of cost. It is essential that drawings are presented

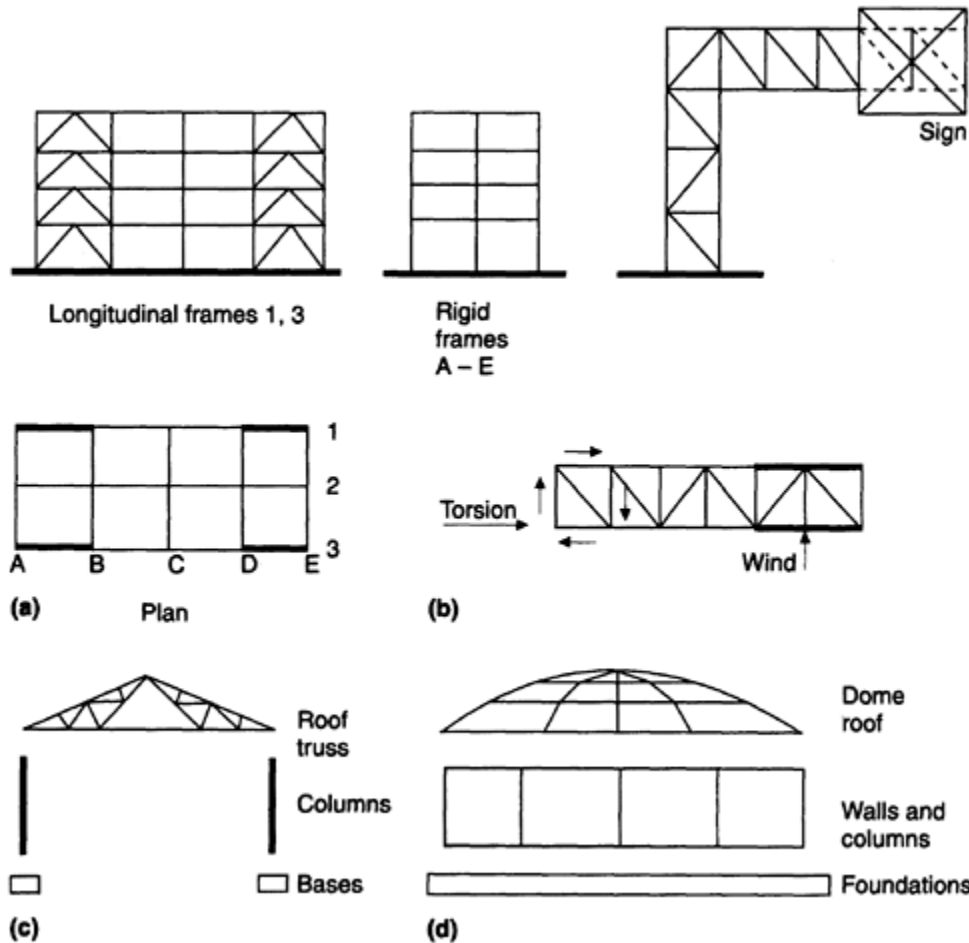

**Fig. 1.6** Idealization of structures: (a) multistorey building; (b) tower structure; (c) truss and stanchion frame; (d) dome roof stadium. correctly and are carefully checked for accuracy. Drawing is an essential part of the design process. The designer must ensure that the detail is such that the structure acts in the way he/she has idealized it for design. He/she must also ensure that all the detailed construction is possible, will not lead to failure and can be painted, inspected and properly maintained.

Steelwork drawings may be classified into:

- general arrangement—showing the function and arrangement of the structure;
- making plans—showing the location of separate numbered members for erection;
- detail drawings—giving details of separate members for fabrication.

Many consulting engineering practices carry out the overall analysis and design only, preparing arrangement drawings showing the member sections required. Special joint types must be carefully specified to achieve the designer’s assumptions in practice. The fabricator then prepares the detail drawings for joints and shop fabrication. This enables the firm to use details and processes with which they are familiar and have the necessary equipment. Computer software is increasingly used to produce arrangement and detail drawings and take off quantities.

The present book is mainly concerned with design. Sketches showing framing arrangements, main loadbearing frames and members and details of important joints are given where appropriate. The purpose is to show the translation of the output of the analysis and design into the practical structure.

### 1.9.2 Specification

The specification and drawings are complementary, each providing information necessary for the execution of the work. In general terms the specification for fabrication and erection includes:

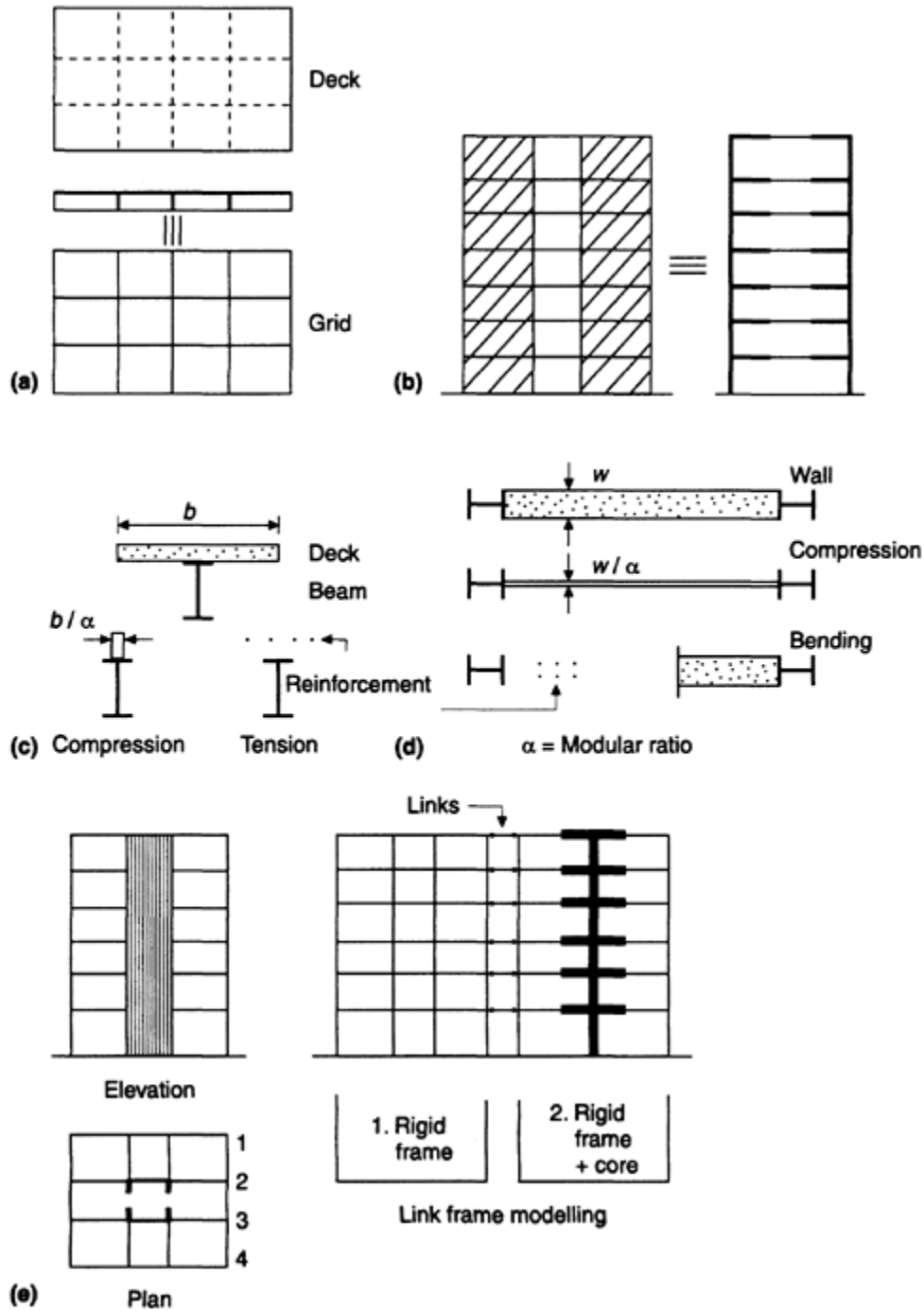

**Fig. 1.7** Modelling for analysis: (a) ribbed deck; (b) connected shear walls; (c) composite beam; (d) shear wall and columns; (e) rigid frame and core building.

1. general description of building, its location, access to site, etc.;
2. description of the structural steelwork involved;
3. types and quality of materials to be used;
4. standard of workmanship required;
5. in some cases the order in which the work is to be carried out and the methods to be used.

Particular clauses in the steelwork specification cover:

1. grades of steel required;

2. workmanship and fabrication process required and the acceptance limits for dimensional accuracy, straightness, drilling etc.;
3. welding, methods and procedures required to eliminate defects and cracking and reduce distortion, testing to be carried out and permissible limits of defects;
4. types and quality of bolts to be used;
5. inspection practice and marking;
6. erection, giving the tolerance permissible for out-of-verticality, procedures for assembly and testing for high-strength friction grip bolt joints and site-welded joints;
7. fire protection methods to be used for the finished steel-framed building;
8. corrosion protection for exposed steelwork where the surface preparation, protection system and testing required are described.

In all cases the specification set out above must comply with the relevant British Standards. The designer must write clauses in the specification to cover special features in the design, fabrication or erection not set out in general clauses in codes and conditions of contract.

The aim is to ensure that the intentions in the design as to structural action, behaviour of materials, robustness and durability etc. are met. Experience and great care are needed in writing the specification.

### 1.9.3 Quantities

Quantities of materials required are taken from the arrangement and detail drawings. The materials required for fabrication and erection are listed for ordering. The list comprises the separate types, sizes and quantities of hot- and cold-rolled sections, flats, plates, slabs, rounds and bolts. It is in the general form:

- mark number
- number off
- description
- weight per metre/square metre/unit length/area
- total weight.

The quantities are presented on standard sheets printed out by computer.

The bill of quantities is a schedule of the materials required and work to be carried out. It provides the basis on which tenders are to be obtained and payment made for work completed. The steelwork to be fabricated and erected is itemized under rolled and built-up beams, girders and columns, trusses and lattice girders, purlins and sheeting rails, bases, grillages, splice plates, bolts etc. The bill requests the rate and amount for each item from which the total cost is estimated.

### 1.10 FABRICATION

Fabrication covers the process of making the individual elements of the steel-framed building from rolled steel sections and plates. The general process is set out briefly as follows:

1. The fabricator prepares the materials lists and drawings showing the shop details.
2. Rolled members are cut to length and drilled by numerically controlled plant.
3. Shapes of gussets, cleats, endplates, stiffeners etc. are marked out and flame or plasma-arc cut and edges are ground. Hole locations are marked and holes drilled.
4. For built-up members, plates are flame or plasma-arc cut, followed by machining for edges and weld preparation.
5. Main components and fittings are assembled and positioned and final welding is carried out by automatic submerged-arc or gas-shielded process. Appropriate measures are taken to control distortion and cracking.
6. Members are cleaned by grit blasting, primed and given their mark number.

Careful design can reduce fabrication costs. Some points to be considered are as follows.

1. Rationalize the design so that as many similar members as possible are used. This will result in extra material being required but will reduce costs.

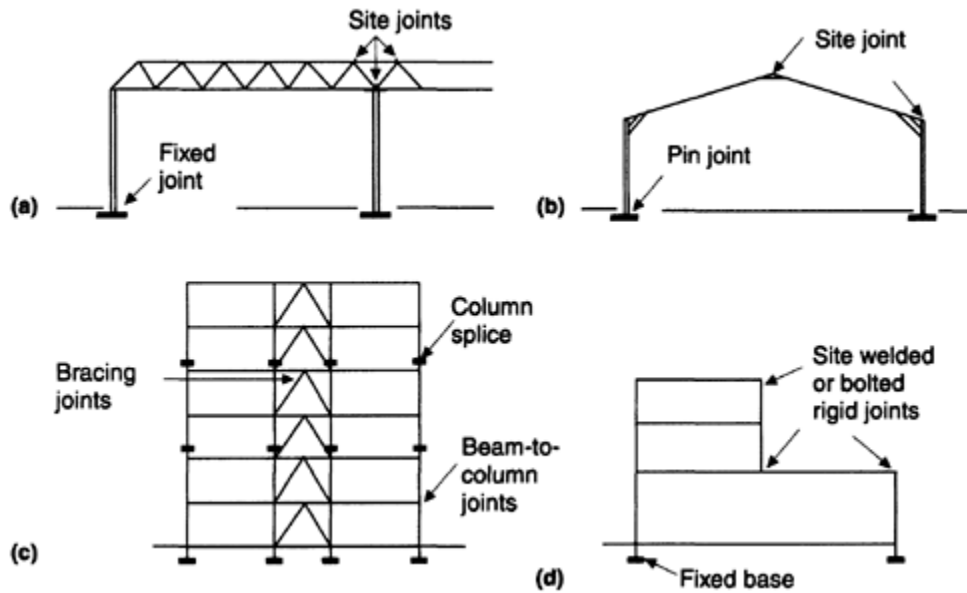

**Fig. 1.8** Types of joints: (a) lattice girder roof building; (b) pinned-base portal—high-grade bolts; (c) simple joints—ordinary bolts; (d) rigid frame.

2. The simplest detail should be used so that welding is reduced to a minimum, sound welds can be assured and inspection and testing carried out easily.
3. Standard bolted connections should be used throughout.

The above is readily achieved in multistorey and standard factory building construction.

### 1.11 TRANSPORT AND ERECTION

Some brief comments are given regarding the effect of transport and erection on design.

1. The location of the site and method of transport may govern the largest size of member. Large members may be transported if special arrangements are made.
2. The method of erection and cranes to be used require careful selection. Mobile cranes can be used for single-storey buildings, while tower cranes or cranes climbing on the steelwork are required for multistorey buildings. Economies are achieved when building components are of similar size and weight, and cranes are used to capacity. Special provisions have to be made to erect large heavy members.

The above considerations affect the number and location of the site joints.

Factors considered in selecting the type of site joint are ease of assembly, appearance and cost. In general, welding is used in shop fabrication and bolts are used for site joints. Ordinary bolts in clearance holes make the cheapest joints and are used generally in all types of construction. Higher grades of ordinary bolts and friction grip fasteners are used for joints in rigid design and where strong joints are needed in simple design. Site welding is the most expensive form of jointing but gives the best appearance, though quality may be difficult to control under site conditions. Welding is essential with heavy rigid construction to achieve full strength joints. Care is needed in design to ensure that welding and inspection can be carried out easily.

Ideally, joints should be located near to points of contraflexure, but such positions may not be convenient for fabrication or erection. Site joints on some types of structures are shown in [Figure 1.8](#).

# CHAPTER 2

## Structural steel design

### 2.1 DESIGN THEORIES

#### 2.1.1 Development of design

The specific aim of structural design is, for a given framing arrangement, to determine the member sizes to support the structure's loads. The historical basis of design was trial and error. Then with development of mathematics and science the design theories—elastic, plastic and limit state—were developed, which permit accurate and economic designs to be made. The design theories are discussed; design methods given in BS 5950: Part 1 are set out briefly. Reference is also made to Eurocode 3 (EC3). The complete codes should be consulted.

#### 2.1.2 Design from experience

Safe proportions for members such as depth/thickness, height/width, span/depth etc. were determined from experience and formulated into rules. In this way, structural forms and methods of construction such as beam-column, arch-barrel vault and domes in stone, masonry and timber were developed, as well as cable structures using natural fibres. Very remarkable structures from the ancient civilizations of Egypt, Greece, Rome and the cathedrals of the middle ages survive as a tribute to the ingenuity and prowess of architects using this design basis. The results of the trial-and-error method still survive in our building practices for brick houses. An experimental design method is still included in the steel code.

#### 2.1.3 Elastic theory

Elastic theory was the first theoretical design method to be developed. The behaviour of steel when loaded below the yield point is much closer to true elastic behaviour than that of other structural materials ([Figure 2.1](#)). All sections and the complete structure are assumed to obey Hooke's law and recover to their original state on removal of load if not loaded past yield. Design to elastic theory was carried out in accordance with BS 449, *The Use of Structural Steel in Building*.

For design the structure is loaded with the working loads, that is the maximum loads to which it will be subjected during its life. Statically determinate structures are analysed using simple theory of statics. For statically indeterminate structures, linear or first-order elastic theory is traditionally used for analysis. The various load cases can be combined by superposition to give the worst cases for design. In modern practice, second-order analysis taking account of deflections in the structure can be performed, for which computer programs and code methods are available. In addition, analysis can be performed to determine the load factor which will cause elastic instability where the influence of axial load on bending stiffness is considered. Dynamic analyses can also be carried out. Elastic analysis continues to form the main means of structural analysis.

In design to elastic theory, sections are sized to ensure permissible stresses are not exceeded at any point in the structure. Stresses are reduced where instability due to buckling such as in slender compression members, unsupported compression flanges of slender beams, deep webs etc. can occur. Deflections under working loads can be calculated as part of the analysis and checked against code limits. The loading, deflection and elastic bending moment diagram and elastic stress distribution for a fixed base portal are shown in [Figure 2.2\(a\)](#).

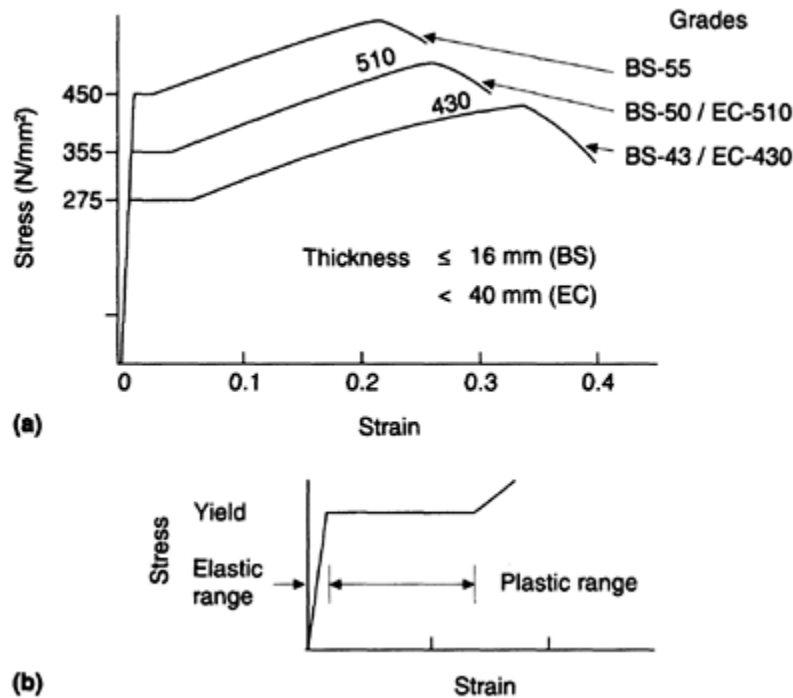

**Fig. 2.1** Stress-strain diagrams: (a) structural steels—BS 5950 and EC3; (b) plastic design.

The permissible stresses are obtained by dividing the yield stress or elastic critical buckling stress where stability is a problem by a factor of safety. The one factor of safety takes account variations in strengths of materials, inaccuracies in fabrication, possible overloads etc. to ensure a safe design.

#### 2.1.4 Plastic theory

Plastic theory was the next major development in design. This resulted from work at Cambridge University by the late Lord Baker, Professors Horne, Heyman etc. The design theory is outlined.

When a steel specimen is loaded beyond the elastic limit the stress remains constant while the strain increases, as shown in [Figure 2.1\(b\)](#). For a beam section subjected to increasing moment this behaviour results in the formation of a plastic hinge where a section rotates at the plastic moment capacity.

Plastic analysis is based on determining the least load that causes the structure to collapse. Collapse occurs when sufficient plastic hinges have formed to convert the structure to a mechanism. The safe load is the collapse load divided by a load factor.

In design the structure is loaded with the collapse or factored loads, obtained by multiplying the working loads by the load factor, and analysed plastically. Methods of rigid plastic analysis have been developed for single-storey and multistorey frames where all deformation is assumed to occur in the hinges. Portals are designed almost exclusively using plastic design. Software is also available to carry out elastic-plastic analysis where the frame first acts elastically and, as the load increases, hinges form successively until the frame is converted to a mechanism. More accurate analyses take the frame deflections into account. These secondary effects are only of importance in some slender sway frames. The plastic design methods for multistorey rigid non-sway and sway frames are given in BS 5950.

The loading, collapse mechanism and plastic bending moment diagram for a fixed-base portal are shown in [Figure 2.2\(b\)](#). Sections are designed using plastic theory and the stress distributions for sections subjected to bending only and bending and axial load are also shown in the figure. Sections require checking to ensure that local buckling does not occur before a hinge can form. Bracing is required at the hinge and adjacent to it to prevent overall buckling.



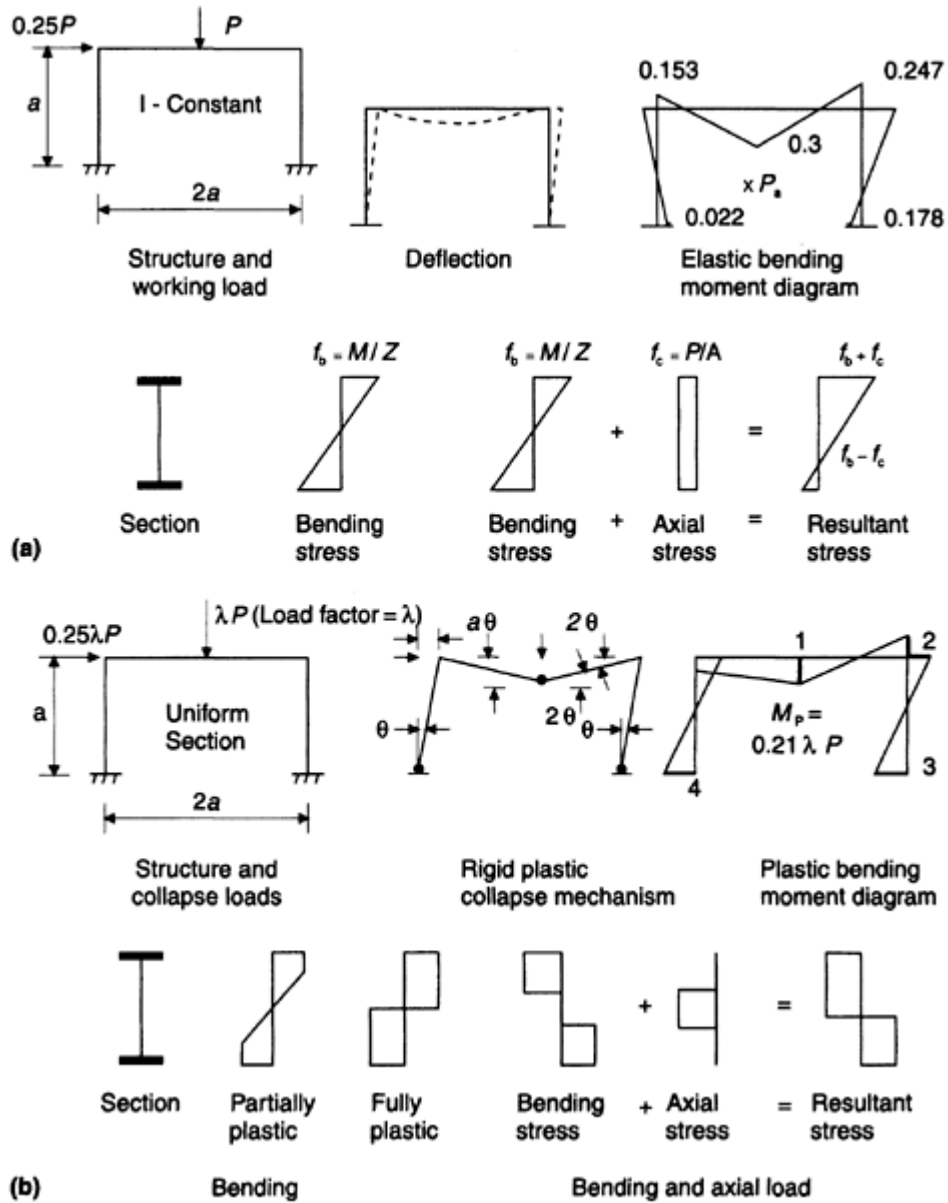

Fig. 2.2 Loading, deflection, bending and stress distributions: (a) elastic analysis; (b) plastic analysis.

### 2.1.5

#### Limit state theory and design codes

Limit state theory was developed by the Comité Européen Du Béton for design of structural concrete and has now been widely accepted as the best design method for all materials. It includes principles from the elastic and plastic theories and incorporates other relevant factors to give as realistic a basis for design as possible. The following concepts are central to limit state theory.

1. Account is taken in design of all separate conditions that could cause failure or make the structure unfit for its intended use. These are the various limit states and are listed in the next section.
2. The design is based on the actual behaviour of materials in structures and performance of real structures established by tests and long-term observations. Good practice embodied in clauses in codes and specifications must be followed in order that some limit states cannot be reached.
3. The overall intention is that design is to be based on statistical methods and probability theory. It is recognized that no design can be made completely safe; only a low probability that the structure will not reach a limit state can be achieved. However, full probabilistic design is not possible at present and the basis is mainly deterministic.

4. Separate partial factors of safety for loads and materials are specified. This permits a better assessment to be made of uncertainties in loading, variations in material strengths and the effects of initial imperfections and errors in fabrication and erection. Most importantly, the factors give a reserve of strength against failure.

The limit state codes for design of structural steel now in use are BS 5950: Part 1 (1990) and Eurocode 3 (1993). All design examples in the book are to BS 5950. Eurocode 3 is not discussed. However, references are made in some cases.

In limit state philosophy, the steel codes are Level 1 safety codes. This means that safety or reliability is provided on a structural element basis by specifying partial factors of safety for loads and materials. All relevant separate limit states must be checked. Level 2 is partly based on probabilistic concepts and gives a greater reliability than a Level 1 design code. A Level 3 code would entail a fully probabilistic design for the complete structure.

## 2.2 LIMIT STATES AND DESIGN BASIS

BS 5950 states in Clause 1.01 that:

The aim of structural design is to provide with due regard to economy a structure capable of fulfilling its intended function and sustaining the design loads for its intended life.

In Clause 2.1.1 the code states:

Structures should be designed by considering the limit states at which they become unfit for their intended use by applying appropriate factors for the ultimate limit state and serviceability limit state.

The limit states specified for structural steel work on BS 5950 are in two categories:

**Table 2.1** Limit states specified in BS 5950

<i>Ultimate</i>	<i>Serviceability</i>
1. Strength including yielding rupture, buckling and transformation into a mechanism	5. Deflection
2. Stability against overtwining and sway	6. Vibration, e.g. wind-induced oscillation
3. Fracture due to fatigue	7. Repairable damage due to fatigue
4. Brittle fracture	8. Corrosion and durability

- ultimate limit states which govern strength and cause failure if exceeded;
- serviceability limit states which cause the structure to become unfit for use but stopping short of failure.

The separate limit states given in Table 1 of BS 5950 are shown in [Table 2.1](#).

## 2.3 LOADS, ACTIONS AND PARTIAL SAFETY FACTORS

The main purpose of the building structure is to carry loads over or round specified spaces and deliver them to the ground. All relevant loads and realistic load combinations have to be considered in design.

### 2.3.1 Loads

BS 5950 classifies working loads into the following traditional types.

1. Dead loads due to the weight of the building materials. Accurate assessment is essential.
2. Imposed loads due to people, furniture, materials stored, snow, erection and maintenance loads. Refer to BS 6399.
3. Wind loads. These depend on the location, the building size and height, openings in walls etc. Wind causes external and internal pressures and suctions on building surfaces and the phenomenon of periodic vortex shedding can cause vibration of structures. Wind loads are estimated from maximum wind speeds that can be expected in a 50-year period. They are to be estimated in accordance with CP3: Chapter V, Part 2. A new wind load code BS 6399: Part 2 is under preparation.

4. Dynamic loads are generally caused by cranes. The separate loads are vertical impact and horizontal transverse and longitudinal surge. Wheel loads are rolling loads and must be placed in position to give the maximum moments and shears. Dynamic loads for light and moderate cranes are given in BS 6399: Part 1.

**Table 2.2** BS 5950 design loads for the ultimate limit state

<i>Load combination</i>	<i>Design load<sup>a</sup></i>
Dead load	1.4 $G_K$
Dead load restraining overturning	1.0 $G_K$
Dead and imposed load	1.4 $G_K$ +1.6 $Q_K$
Dead, imposed and wind load	1.2 ( $G_K$ + $Q_K$ + $W_K$ )

<sup>a</sup> $G_K$ =dead load;  $Q_K$ =imposed load;  $W_K$ =wind load.

Seismic loads, though very important in many areas, do not have to be considered in the UK. The most important effect is to give rise to horizontal inertia loads for which the building must be designed to resist or deform to dissipate them. Vibrations are set up, and if resonance occurs, amplitudes greatly increase and failure results. Damping devices can be introduced into the stanchions to reduce oscillation. Seismic loads are not discussed in the book.

### 2.3.2

#### Load factors/partial safety factors and design loads

Load factors for the ultimate limit state for various loads and load combinations are given in Table 2 of BS 5950. Part of the code table is shown in [Table 2.2](#).

In limit state design,

Design loads=characteristic or working loads  $F_K$  × partial factor of safety  $\gamma$

### 2.4

#### STRUCTURAL STEELS—PARTIAL SAFETY FACTORS FOR MATERIALS

Some of the design strengths,  $p_y$ , of structural steels used in the book, taken from Table 6m in BS 5950, are shown in [Table 2.3](#).

Design strength is given by

$$\text{Design strength} = \frac{\text{Yield on characteristic strength}}{\text{Partial factor of safety } \gamma_m}$$

**Table 2.3** BS 5950 design strength  $p_y$

<i>Grade</i>	<i>Thickness (mm)</i>	<i><math>p_y</math> (N/mm)</i>
43	≤16	275
	≤40	265
50	≤16	355
	≤40	345

In BS 5950, the partial safety factor for materials  $\gamma_m$ =1.0. In Eurocode 3 the partial safety factors for resistance are given in [Section 5.1.1](#). The value for member design is normally 1.1.

### 2.5

#### DESIGN METHODS FROM CODES—ULTIMATE LIMIT STATE

### 2.5.1

#### Design methods from BS 5950

The design of steel structures may be made to any of the following methods set out in Clause 2.1.2 of BS 5950:

- simple design;

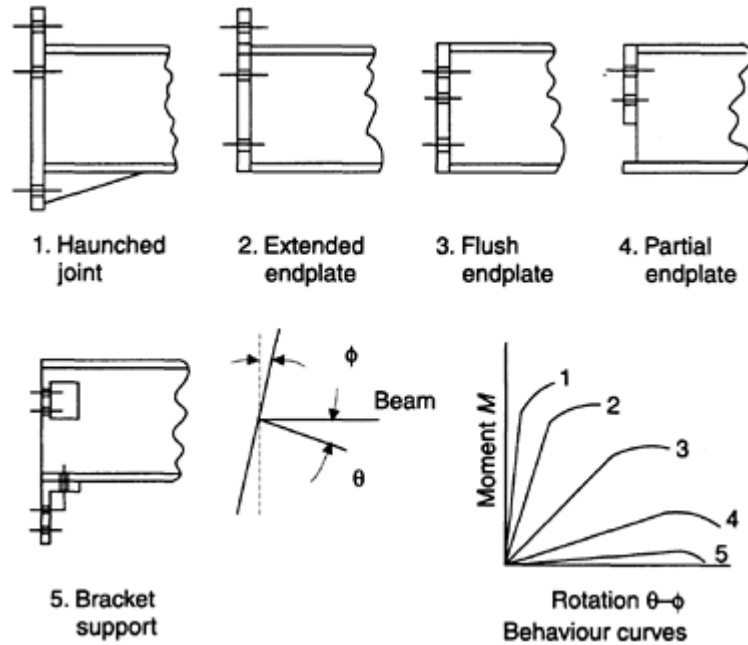

Fig. 2.3 Beam-column joint behaviour curves.

- rigid design;
- semirigid design;
- experimental verification.

The clause states that:

the details of members and connections should be such as to realize the assumptions made in design without adversely affecting other parts of the structure.

(a)  
*Simple design*

The connections are assumed not to develop moments that adversely affect the member or structure. The structure is analysed, assuming that it is statically determinate with pinned joints. In a multistorey beam-column frame, bracing or shear walls acting with floor slabs are necessary to provide stability and resistance to horizontal loading.

(b)  
*Rigid design*

The connections are assumed to be capable of developing actions arising from a fully rigid analysis, that is, the rotation is the same for the ends of all members meeting at a joint.

The analysis of rigid structures may be made using either elastic or plastic methods. In Section 5 of the code, methods are given to classify rigid frames into non-sway, i.e. braced or stiff rigid construction and sway, i.e. flexible structures. The non-sway frame can be analysed using first-order linear elastic methods including subframe analysis. For sway frames, second-order elastic analysis or methods given in the code (extended simple design or the amplified sway method) must be used. Methods of plastic analysis for non-sway and sway frames are also given.

(c)  
*Semirigid design*

The code states that in this method some degree of joint stiffness short of that necessary to develop full continuity at joints is assumed. The relative stiffnesses of some common bolted joints are shown in the behaviour curves in [Figure 2.3](#). Economies

in design can be achieved if partial fixity is taken into account. The difficulty with the method lies in designing a joint to give a predetermined stiffness and strength.

The code further states that the moment and rotation capacity of the joint should be based on experimental evidence which may permit some limited plasticity. However, the ultimate tensile capacity of the fastener is not to be the failure criterion. Computer software where the semirigid joint is modelled by an elastic spring is available to carry out the analyses. The spring constant is taken from the initial linear part of the behaviour curve. Plastic analysis based on joint strength can also be used.

The code also gives an empirical design method. This permits an allowance to be made in simple beam-column structures for the inter-restraint of connections by an end moment not exceeding 10% of the free moment. Various conditions that have to be met are set out in the clause. Two of the conditions are as follows.

- The frame is to be braced in both directions.
- The beam-to-column connections are to be designed to transmit the appropriate restraint moment in addition to the moment from eccentricity of the end reactions, assuming that the beams are simply supported.

(d)

#### *Experimental verification*

The code states that where the design of a structure or element by the above methods is not practicable, the strength, stability and stiffness may be confirmed by loading tests as set out in Section 7 of the code.

### **2.5.2**

#### **Analysis of structures—Eurocode 3**

The methods of calculating forces and moments in structures given in Eurocode 3, [Section 5.2](#) are set out briefly.

1. Statically determinate structures—use statics.
2. Statically indeterminate structures—elastic global analysis may be used in all cases. Plastic global analysis may be used where specific requirements are met.
3. Elastic analysis—linear behaviour may be assumed for first- and second-order analysis where sections are designed to plastic theory. Elastic moments may be redistributed.
4. Effects of deformation—elastic first-order analyses is permitted for braced and non-sway frames. Second-order theory taking account of deformation can be used in all cases.
5. Plastic analysis—either rigid plastic or elastic-plastic methods can be used. Assumptions and stress-strain relationships are set out. Lateral restraints are required at hinge locations.

### **2.5.3**

#### **Member and joint design**

Provisions for member design from BS 5950 and are set out briefly.

1. Classification of cross-sections—in both codes, member cross-sections are classified into plastic, compact, semicompact and slender. Only the plastic cross-section can be used in plastic analysis ((d) below).
2. Tension members—design is based on the net section. The area of unconnected angle legs is reduced.
3. Compression members:
  - Short members—design is based on the squash resistance;
  - Slender members—design is based on the flexural buckling resistance.
4. Beams—bending resistances for various cross-section types are:
  - plastic and compact—design for plastic resistance;
  - semicompact—design for elastic resistance;
  - slender—buckling must be considered;
  - biaxial bending—use an interaction expression.
  - bending with unrestrained compression flange—design for lateral torsional buckling.

Shear resistance and shear buckling of slender webs to be checked. Tension field method of design is given in both codes.

Combined bending and shear must be checked in beams where shear force is high.

Webs checks—check web crushing and buckling in both codes.

A flange-induced buckling check is given in Eurocode No. 3.

5. Members with combined tension and moment—checks cover single axis and biaxial bending.

- interaction expression for use with all cross-sections;
- more exact expression for use with plastic and compact cross-sections where the moment resistance is reduced for axial load.

6. Members with combined compression and moment—checks cover single axis and biaxial bending:

- local capacity check—interaction expression for use with all cross-sections; more exact expression for use with plastic and compact cross-sections where the moment resistance is reduced for axial load;
- overall buckling check—simplified and more exact interaction checks are given which take account of flexural and lateral torsional buckling.

7. Members subjected to bending shear and axial force—design methods are given for members subjected to combined actions.

8. Connections—procedures are given for design of joints made with ordinary bolts, friction grip bolts, pins and welds.

## 2.6

### STABILITY LIMIT STATE

Design for the ultimate limit state of stability is of the utmost importance. Horizontal loading is due to wind, dynamic and seismic loads and can cause overturning and failure in a sway mode. Frame imperfections give rise to sway from vertical loads.

BS 5950 states that the designer should consider stability against overturning and sway stability in design.

1. Stability against overturning—to ensure stability against overturning, the worst combination of factored loads should not cause the structure or any part to overturn or lift off its seating. Checks are required during construction.
2. Sway stability—the structure must be adequately stiff against sway. The structure is to be designed for the applied horizontal loads and in addition a separate check is to be made for notional horizontal loads. The notional loads take account of imperfections such as lack of verticality. The loads applied horizontally at roof and floor level are taken as the greater of:
  - 1% of the factored dead loads;
  - 0.5% of the factored dead plus imposed load.

Provisions governing their application are given.

## 2.7

### DESIGN FOR ACCIDENTAL DAMAGE

#### 2.7.1

##### **Progressive collapse and robustness**

In 1968, a gas explosion near the top of a 22-storey precast concrete building blew out side panels, causing building units from above to fall onto the floor of the incident. This overloaded units below and led to collapse of the entire corner of the building. A new mode of failure termed ‘progressive collapse’ was identified where the effects from a local failure spread and the final damage is completely out of proportion to the initial cause. New provisions were included in the Building Regulations at that time to ensure that all buildings of five stories and over in height were of sufficiently robust construction to resist progressive collapse as a result of misuse or accident.

### 2.7.2 Building Regulations 1991

In Part A, *Structure of the Building Regulations*, Section 5, A3/A4 deals with disproportionate collapse. The Regulations state that all buildings must be so constructed as to reduce the sensitivity to disproportionate collapse due to an accident. The main provisions are summarized as follows.

1. If effective ties complying with the code are provided, no other action is needed ([Section 2.7.3\(a\)](#)).
2. If ties are not provided, then a check is to be made to see if loadbearing members can be removed one at a time without causing more than a specified amount of damage.
3. If in (2), it is not possible in any instance to limit the damage, the member concerned is to be designed as a 'protected' or 'key' member. It must be capable of withstanding  $34 \text{ kN/m}^2$  from any direction.
4. Further provisions limit damage caused by roof collapse.

The Building Regulations should be consulted.

### 2.7.3 BS 5950 Requirements for structural integrity

Clause 2.4.5 of BS 5950 ensures that design of steel structures complies with the Building Regulations. The main provisions are summarized. The complete clause should be studied.

#### (a) *All buildings*

Every frame must be effectively tied at roof and floors and columns must be restrained in two directions at these levels. Beam or slab reinforcement may act as ties, which must be capable of resisting a force of 75 kN at floor level and 40 kN at roof level.

#### (b) *Certain multistorey buildings*

To ensure accidental damage is localized the following recommendations should be met.

- Sway resistance—no substantial part of a building should rely solely on a single plane of bracing in each direction.
- Tying—ties are to be arranged in continuous lines in two directions at each floor and roof. Design forces for ties are specified. Ties anchoring columns at the periphery should be capable of resisting 1% of the vertical load at that level.
- Columns—column splices should be capable of resisting a tensile force of two-thirds of the factored vertical load.
- Integrity—any beam carrying a column should be checked for localization of damage ((c) below).
- Floor units should be effectively anchored to their supports.

#### (c) *Localization of damage*

The code states that a building should be checked to see if any single column or beam carrying a column could be removed without causing collapse of more than a limited portion of the building. If the failure would exceed the specified limit the element should be designed as a key element. In the design check the loads to be taken are normally dead load plus one-third wind load plus one-third imposed load; the load factor is 1.05. The extent of damage is to be limited.

#### (d) *Key element*

A key element is to be designed for the loads specified in (c) above plus the load from accidental causes of  $34 \text{ kN/m}^2$  acting in any direction.

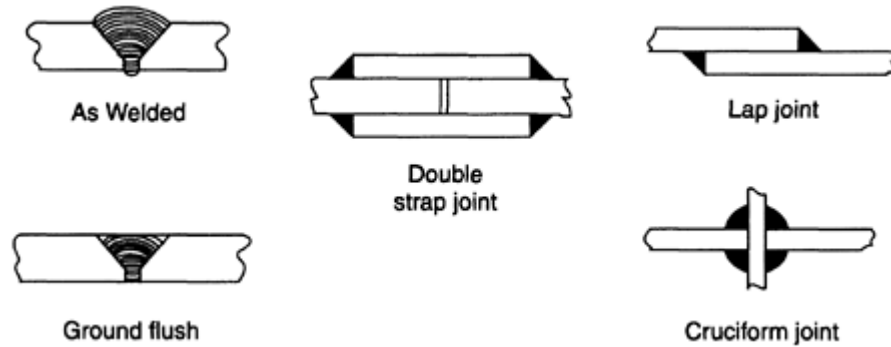

Fig. 2.4 Load-carrying welds.

## 2.8

### SERVICEABILITY LIMIT STATES

The serviceability limit states are listed in BS 5950 as deflection, vibration, repairable damage due to fatigue and corrosion. Deflection limits and vibration will be discussed in this section. Fatigue and corrosion are treated in Section 2.10.

Breaching serviceability limit states renders the structure visually unacceptable, uncomfortable for occupants or unfit for use without causing failure. Exceeding limits can also result in damage to glazing and finishes.

#### 2.8.1

##### Deflection limits

Deflection is checked for the most adverse realistic combination of serviceability loads. The structure is assumed to be elastic. Deflection limits are given in Table 5 of BS 5950. Some values are:

- Beams carrying plaster—span/360;
- Horizontal deflection of columns in each storey of a multistorey building—storey height/300.

#### 2.8.2

##### Vibration

Design for vibration is outside the scope of the book. Some brief notes are given.

Vibration is caused by wind-induced oscillation, machinery and seismic loads. People walking on slender floors can also cause vibration. Resonance occurs when the period of the imposed force coincides with the natural period of the structure when the amplitude increases and failure results. Damping devices can be installed to reduce the amplitude.

Wind loading can cause flexible tall buildings and stacks to vibrate at right angles to the wind direction due to vortex shedding. Gust-induced vibration occurs in the wind direction. Designs are made to ensure that resonance does not occur or devices to break up vortices are installed. Long-span flexible roofs such as cable, girder or net are prone to aerodynamic excitation.

## 2.9

### DESIGN CONSIDERATIONS

Other considerations listed as limit states in BS 5950 are discussed.

#### 2.9.1

##### Fatigue

In BS 5950, fatigue failure is an ultimate limit state, but, if repairable, a serviceability limit state failure occurs in members subjected to variable tensile stress, which may be at values well below failure stress. There is virtually no plastic deformation. Bridges, crane girders, conveyor gantries etc. are subject to fatigue.

Fatigue tests are carried out to determine endurance limits for various joints and members. Failure usually occurs at welded joints. Tests subjecting joints to pulsating loads are made. Some types of welded joints tested are shown in Figure 2.4.

The joint giving the least disturbance to stress flow gives the best results. Some comments on welded construction are as follows.



1. Butt welds give the best performance. Fatigue strength is increased by grinding welds flush.
2. Fillet-welded joints do not perform well. The joints in order of performance are shown in [Figure 2.4](#). The effect of non-loadbearing fillet welds is also significant.
3. For plate girders the best results are given when the web flange weld is continuous and made by an automatic process. Intermittent welds give low fatigue strength.

Structures are usually subjected to widely varying or random stress cycles. Methods are available for estimating the cumulative damage for a given load spectrum. The life expectancy of the structure can be estimated if the maximum stress is specified.

Some 'good practice' provisions in design are as follows.

1. Avoid stress concentrations in regions of tensile stress, e.g. taper thicker plates to meet thinner plates at joints, locate splices away from points of maximum tensile stress, and use continuous automatic welding in preference to intermittent or manual welding.
2. Reduce working stresses depending on the value of the maximum tensile stress, the ratio of maximum to minimum stress, the number of cycles and the detail.
3. No reduction in ability to resist fatigue is needed for bolted joints. Sound, full penetration butt welds give the best performance.
4. Cumulative damage must be considered.

BS 5950 states that fatigue need only be considered when the structure or element is subjected to numerous stress fluctuations. Wind-induced oscillation should be considered. Fatigue must be taken into account in some heavy crane structures.

## 2.9.2

### Brittle fracture

Brittle fracture starts in tensile stress areas at low temperatures and occurs suddenly with little or no prior deformation. It can occur at stresses as low as one-quarter of the yield stress and it propagates at high speed with the energy for crack advance coming from stored elastic energy.

The mode of failure is by cleavage, giving a rough surface with chevron markings pointing to the origin of the crack. A ductile fracture occurs by a shear mechanism. The change from shear to cleavage occurs through a transition zone at 0°C or lower. The Charpy V-notch test, where a small beam specimen with a specified notch is broken by a striker is the standard test. The energy to cause fracture is measured at various temperatures. The fracture becomes more brittle and energy lower at lower temperatures. Steels are graded A-E in order of increasing notch ductility or resistance to brittle fracture.

The likelihood of brittle fracture occurring is difficult to predict with certainty. Important factors involved are as follows.

- Temperature—fractures occur more frequently at low temperatures.
- Stress—fractures occur in regions of tensile stress.
- Plate thickness—thick plates, which are more likely to contain defects, have a higher risk of failure.
- Materials—alloys included and production processes produce small grain size in steels which improves fracture toughness at low temperatures.

Precautions necessary to reduce the likelihood of brittle fracture occurring are as follows.

- Materials—select steels with high Charpy value and use thin plate.
- Design detail—some obvious 'don'ts' are:
  - avoid abrupt changes of section; taper a thick plate to meet a thin one;
  - do not locate welds in tension in high stress areas;
  - fillet welds should not be made across tension flanges;
  - avoid intermittent welds.

Detailing should be such that inspection and weld testing can be readily carried out.

- Fabrication—flame cut edges should be ground off. Welding practice should be of highest quality and adequate testing carried out.
- Erection—no bad practices such as burning holes or tack-welding temporary fixings should be permitted.

Brittle fracture is an ultimate limit state in BS 5950. Maximum thickness of sections and plates for various grades of steels are given in Table 4 in the code.

### 2.9.3 Corrosion protection

Corrosion and durability is a listed serviceability limit state in BS 5950. Steels are particularly susceptible to corrosion, an electrochemical process where iron is oxidized in the presence of air, water and other pollutants. Corrosion is progressive and leads to loss of serviceability and eventual failure. It is very necessary to provide steelwork with suitable protection against corrosion. The choice of system depends on the type and degree of pollution and length of life required. A long maintenance-free life is assured if the correct system is used and applied correctly (BS 5493, 1977).

Surface preparation is the most important single factor in achieving successful protection against corrosion. All hot-rolled steel products are covered with a thin layer of iron oxide termed mill scale. If this is not removed, it will break off under flexure or abrasion and expose the steel to rusting. All mill scale, rust and slag spatter from welding must be removed before paint is applied. Methods of surface preparation are:

- manual cleaning using scrapers and brushes etc.;
- flame cleaning using a torch to loosen the scale, which may be removed by brushing;
- pickling in a tank of acid, used as a preparation for galvanizing;
- blast cleaning, where iron grit or sand is projected against the steel surface; manual and automatic processes are used.

BS 5493 defines cleanliness quality and the desirable surface profile for the cleaned steel.

Two types of protective coatings used are:

- metallic—metal spraying and galvanizing;
- non-metallic—paint systems.

Metal spraying is carried out by atomizing metal wire or powder by oxyacetylene flame in a gun and projecting the molten droplets onto the surface of the steel part. Zinc and aluminium coatings are used.

In hot-dip galvanizing, rust and mill scale are removed by pickling and the cleaned metal is immersed in a bath of molten zinc. The thickness of coating depends on the time of immersion and speed of withdrawals.

A common paint system consists of a primer of zinc chromate or phosphate and under coat and finish coat of micaceous iron oxide paint. Many other paint types are used (chlorinated rubber, epoxy, urethane, bituminous paints etc.).

The design and details can greatly influence the life of a paint coating. Some important points are as follows.

- Use detail that sheds water, and avoid detail which provides places where water can be trapped, such as in upturned channel sections. If such sections are unavoidable, they should have drain holes.
- Box sections should be sealed.
- Access for maintenance should be provided.

BS 5493 gives recommendations for design and detail.

Weathering steels containing copper, nickel and chromium can also be used. The alloying elements form a dense self-healing rust film which protects the steel from further corrosion. These steels are used in exposed skeletal structures.

### 2.9.4 Fire protection

(a)

#### *General considerations*

Fire causes injury and loss of life, damage to and destruction of finishes, furnishings and fittings and damage to and failure of the structure itself. Design must aim at the prevention or minimization of all of the above effects. Injury and loss of life are caused by toxic gases generated by combustion of furnishings etc., as well as by heat. Destruction of property and structural damage and failure are caused by heat and burning of combustible material.

The means of prevention and control of damage may be classified as:

- early detection by smoke and heat detectors or manual sighting followed by extinction of the fire by automatic sprinklers, manual application of water, foams etc.;
- containment by dividing the building into fireproof compartments to prevent fire spread and smoke travels, and provision of fireproof escape routes;
- fire protection of loadbearing structural members to ensure collapse does not occur before people can escape or the fire be extinguished and that the building can be subsequently repaired.

The last two control methods form an essential part of the design considerations for steel structures. All multistorey commercial and residential buildings require fire protection of structural members, but single-storey and some other industrial buildings do not need protection.

(b)

*Fire and structural steelwork, fire resistance*

Structural steelwork performs badly in fire. Temperatures commonly reach 1200°C at the seat of the fire, while the critical temperature for steel is about 550°C. At this temperature the yield stress of steel has fallen to about 0.7 of its value at ambient temperatures that is to the stress level in steel at working loads.

The Fire Research Station carries out tests to determine the behaviour of steel members in fire and the efficiency of protective measures. The ability of a structural element to continue to support load is termed the fire resistance and this is stated in terms of time (½, 1, 2, 4 h). Fire resistance is determined by testing elements and protection systems in furnaces heated to various temperatures up to 1100°C. The resistance required depends on the type and height of buildings, contents and the type and location of the structural member and whether a fire extinguishing system is provided. This is given in the Building Regulations.

(c)

*Type of fire protection*

Examples of fire protection for columns and floor beams in steel-framed buildings are shown in [Figure 2.5](#). Fire resistance periods for various types of protection have been established by tests on loaded structural members (details in BS 476). Some notes on the various types of protection used are given below.

- Solid protection for columns, where the concrete assists in carrying the load, is not much used in modern construction. Beams can also be cased in concrete. A concrete thickness of 50 mm will give 2 h protection.
- Brick-clad steel-framed buildings, where brick provides the walling and fire protection, are a popular building system.
- Hollow casing can be applied in the form of pre-fabricated casing units or vermiculite gypsum plaster placed on metal lathing.
- Profile casing, where vermiculite cement is sprayed on to the surface of the steel member, is the best system to use for large plate and lattice girders and is the cheapest protection method. A thickness of 38 mm of cement lime plaster will give 2 h protection.
- Intumescent coatings inflate into foam under the action of heat to form the protective layer.
- Fire resistant ceilings are used to protect floor steel.

Another system of fire protection that can be used with frames of box sections is to fill these with water, which is circulated through the members. This method has been used in Europe and the United States. The aim of the method is to ensure the steel temperature does not reach a critical level.

Concrete-filled hollow sections also have increased fire resistance.

(d)

*Fire engineering*

A scientific study of fires and behaviour of structures in fire has led to the development of fire engineering. Most of the work has been carried out in Sweden. The aims of the method are to determine fire load and predict the maximum temperatures in the steel frame and its resistance to collapse. The method can be used to justify leaving steelwork unprotected in certain types of building.

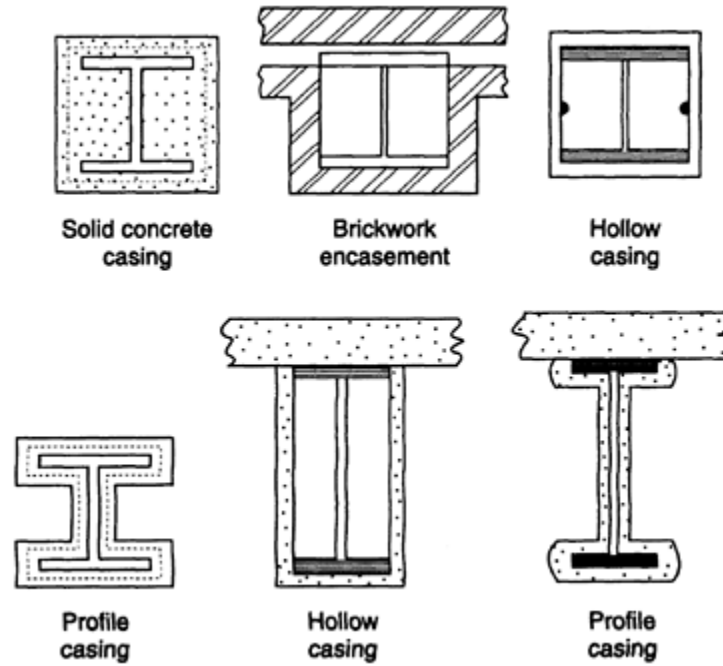

Fig. 2.5 Types of fire protection for columns and beams.

(e)  
*Building Regulations*

The statutory requirements for fire protection are set out in the Building Regulations, Part B, *Fire Safety*. A brief summary of the main provisions is as follows.

- Buildings are classified according to use, which takes account of the risk, severity of possible fire or danger to occupants. Assembly and recreational, industrial and storage buildings carry the highest risk.
- Large buildings must be divided into fireproof compartments to limit fire spread. The compartment size depends on the use, fire load, ease of evacuation, height and availability of sprinklers.
- Minimum periods of fire resistance are specified for all buildings. These depend on the purpose group, building height, and whether a sprinkler system is installed.
- Every loadbearing element, that is frame, beam, column or wall, must be so constructed as to have the fire resistance period specified.

The complete Building Regulations should be consulted.

(f)  
*BS 5950 Part 8: Fire Protection*

BS 5950: Part 8 sets out data and procedures for checking fire resistance and designing protection for members in steel-framed buildings. Some of the main provisions in the code are summarized below.

- Strength reduction factors for steel members at elevated temperatures are given.
- Methods for determining the strength of members at high temperatures which depend on the limiting temperatures of protected and unprotected members are given. These can be used to establish if loadbearing steelwork can be left unprotected.
- Procedures to be followed to determine the thickness of fire protection required by testing, or from calculations using specified material properties, are given.

The code also has provisions for portal frames, slabs, walls, roofs, concrete-filled hollow sections, water-filled hollow sections etc. The code should be consulted.

# CHAPTER 3

## Preliminary design

### 3.1 GENERAL CONSIDERATIONS

Preliminary design may be defined as a rapid approximate manual method of designing a structure as opposed to carrying out rigorous analysis and detailed design. The overall aim for a given structure is to identify critical loads, estimate design actions and select sections. The problem is bound up with conceptual design, alternative systems, idealization, identification of critical members and rationalization. The process depends greatly on the designer's experience and use of appropriate design aids. The term is also often applied to manual design.

### 3.2 NEED FOR AND SCOPE OF PRELIMINARY DESIGN METHODS

Preliminary design is needed for the following reasons:

- to obtain sections and weights for cost estimation;
- to compare alternative proposals;
- to obtain initial sections for computer analysis;
- to check a completed design.

The need for approximate manual methods is more important than ever because a 'black box' design era is taking over. It is necessary to know if output is right, wrong or complete nonsense. Preliminary design must not replace normal rigorous design and certified checking must still be carried out.

Methods of preliminary analysis that are not dependent on member sizes are set out for both elastic and plastic theories. Redundant structures are treated as statically determinate by approximately locating points of contraflexure by use of subframes or by assigning values of actions at critical positions. Handbooks give solutions to commonly used members and frames such as continuous beams and portals.

Design aids for sizing members are given in many handbooks in tabular and chart form (*Steel Designers Manual* 1986, 1994; Steel Construction Institute, 1987). These give load capacities for a range of sections taking account of buckling where appropriate.

### 3.3 DESIGN CONCEPT, MODELLING AND LOAD ESTIMATION

#### 3.3.1 Design concept

Alternative designs should be considered. Some implications are set out. Two examples are:

- single-storey industrial buildings ([Figure 1.4](#))
  - lattice girders and cantilever columns;
  - portal frames;

- circular multistorey buildings (Figure 1.2)
  - core and perimeter columns;
  - core, umbrella girder and perimeter hangers.

In both examples, all systems have been used. It is not clear which gives the most economical solution. Often steel weights are nearly the same for each system. In multistorey buildings the steel frame is only about 15% of the total cost, so a small weight saving indicated by a preliminary design is of doubtful value. Decisions are often made on grounds other than cost.

The design concept should express clear force paths. It should include, where possible, repetition of members, floor panel sizes, column stacks, frames and bracing, so only a small number of separate members or frames need be designed.

### 3.3.2 Modelling

Some points relevant to modelling for preliminary design are set out.

- In a new structure the designer can model it such that it is statically determinate. The sections from this design could be used as input for a redundant structure. The simple structure will give indicative sizes for costing.
- In checking a finished design or evaluating an existing structure, the design concept and model must be established and loadbearing elements and frames identified. The approximate design check can then proceed.

### 3.3.3 Load estimation

Typical dead load values for various types of construction are required. These are available from hand books. Imposed loads are given the code. Some comments on load estimation are as follows.

- Most loads are distributed. Beam and column reactions are point loads. Floor loading is expressed as equivalent uniform loads.
- Loads are assessed on the tributary floor area supported by the member.
- Loads are cumulative from roof down. Imposed loads are reduced depending on the number of floors involved.
- Wind loads generally act horizontally, but uplift due to suction is important in some cases.
- The structure is taken to be pin jointed for load estimation.

## 3.4 ANALYSIS

The purpose of analysis is to determine the critical actions for design. Some methods that can be used in preliminary analysis are given.

### 3.4.1 Statically determinate structures

Figure 3.1 shows some common types of statically determinate construction.

#### (a) *Floor systems*

The floor system (Figure 3.1 (a)) consists of various types of simply supported beams. For uniform loads the maximum moment is  $WL^2/8$  where  $W$  is the design load and  $L$  is the span. This gives a safe design whether the beams are continuous or not or some two-way action in the slab is considered.

(b)

*Columns in multistorey buildings*

Columns are designed for axial load and moment due to eccentric floor beams [Figure 3.1\(a\)](#). Loads are estimated as set out in [section 3.3.3](#). Beam reactions act at a nominal 100 mm from the column face. The resulting moment may be divided equally between upper and lower lengths as an approximation.

(c)

*Lattice girders, trusses and bracing*

For lattice girders ([Figure 3.1\(b\)](#)), the critical actions are

$$\text{Chord at mid-span} = WL/8d$$

$$\text{Web member at support} = WS/2d$$

where  $W$  is the design load;  $d$  is the depth of girder;  $S$  is the length of web member.

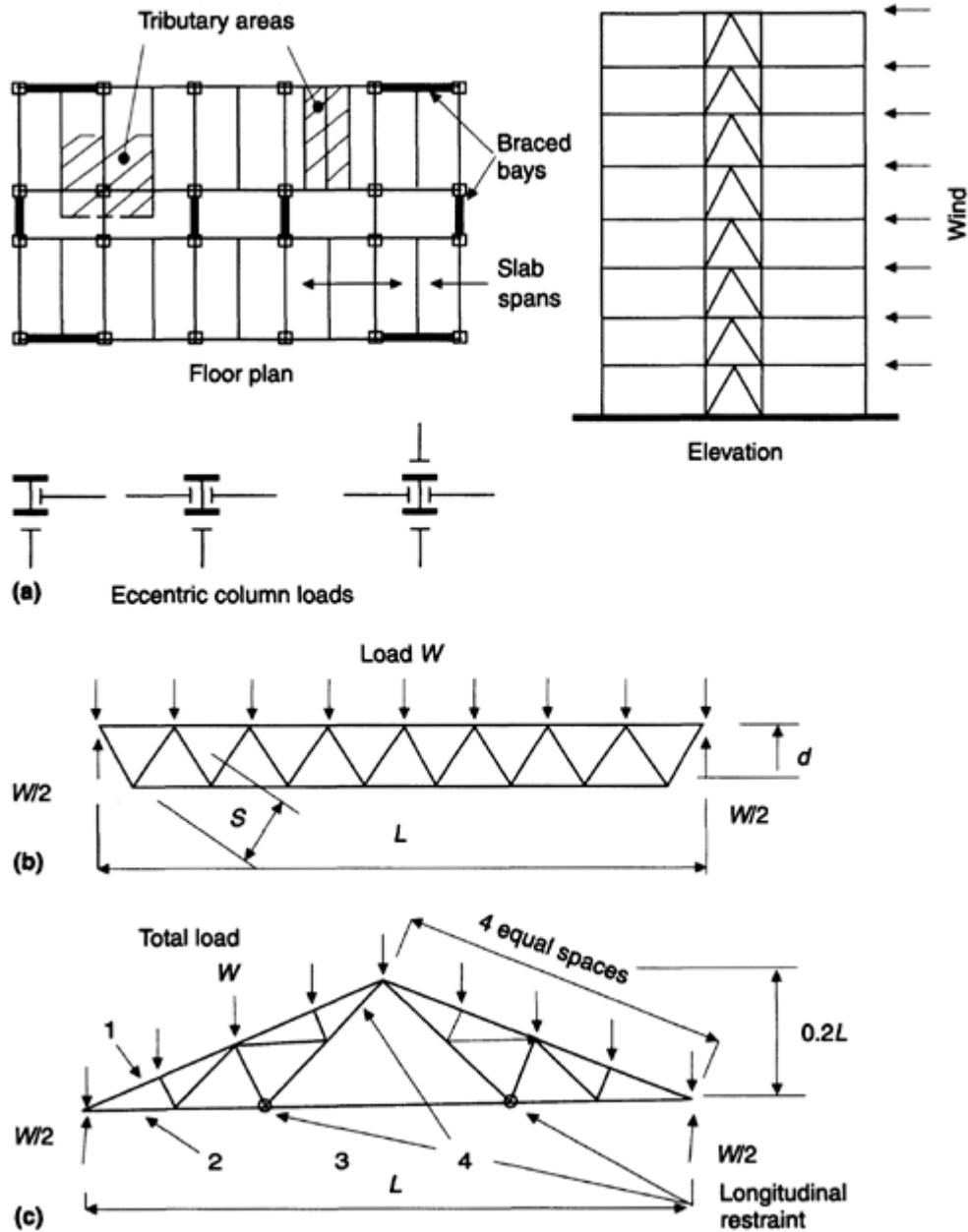

Fig. 3.1 Statically determinate structures: (a) multistorey building; (b) lattice girder; (c) roof truss.

For a Pitched roof truss (Figure 3.1(c)), force coefficients can be determined for a given truss such as the Fink truss shown. The axial forces are

Top chord, member 1:  $F = -1.18W$  max. Bottom chord, member 2:  $F = 1.09W$  max. Web members 3, 4:  $F = -0.23W, +0.47W$  where  $W$  is the total load. Tension is negative, compression positive.

(d)  
Three-pinned portal

For the three-pinned portal (Figure 3.2),

$$\text{Horizontal reaction } H = WL/8h$$

$$\text{Eaves moment } M_x = Ha$$

where  $W$  is the vertical load;  $L$  is the span;  $h$  is the height to crown;  $a$  is the height of columns.



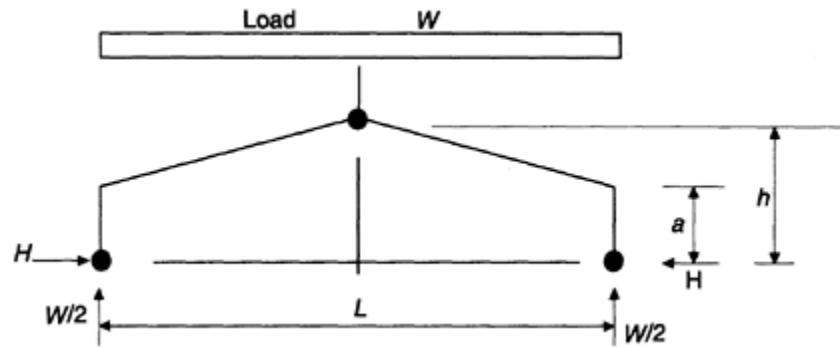

Fig. 3.2 Three-pinned portal.

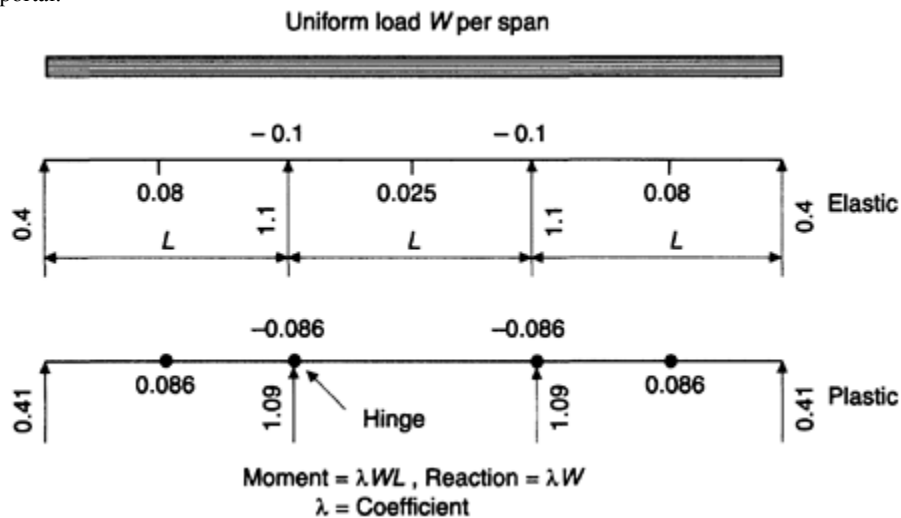

Fig. 3.3 Continuous beam.

### 3.4.2

#### Statically indeterminate structures

(a)

*General comments*

For elastic analysis, if the deflected shape under load is drawn, the point of contraflexure may be located approximately and the structure analysed by statics. The method is generally not too accurate.

For plastic analysis, if sufficient hinges are introduced to convert the structure to a mechanism, it is analysed by equating external work done by the loads to internal work in the hinge rotations. The plastic moment must not be exceeded outside the hinges.

Design aids in the form of formulae, moment and shear coefficients, tables and charts are given in handbooks (*Steel Designers Manual*, 1986, 1994). Some selected solutions are given.

(b)

*Continuous beams*

The moment coefficients for elastic and plastic analysis for a continuous beam of three equal spans are shown in [Figure 3.3](#).

(c)

*Pitched roof pinned-base portal*

Portal design is usually based wholly on plastic theory ([Figure 3.4](#)). As a design aid, solutions are given in chart form for a range of spans. A similar chart could be constructed for elastic design ([Chapter 4](#) gives detailed designs).

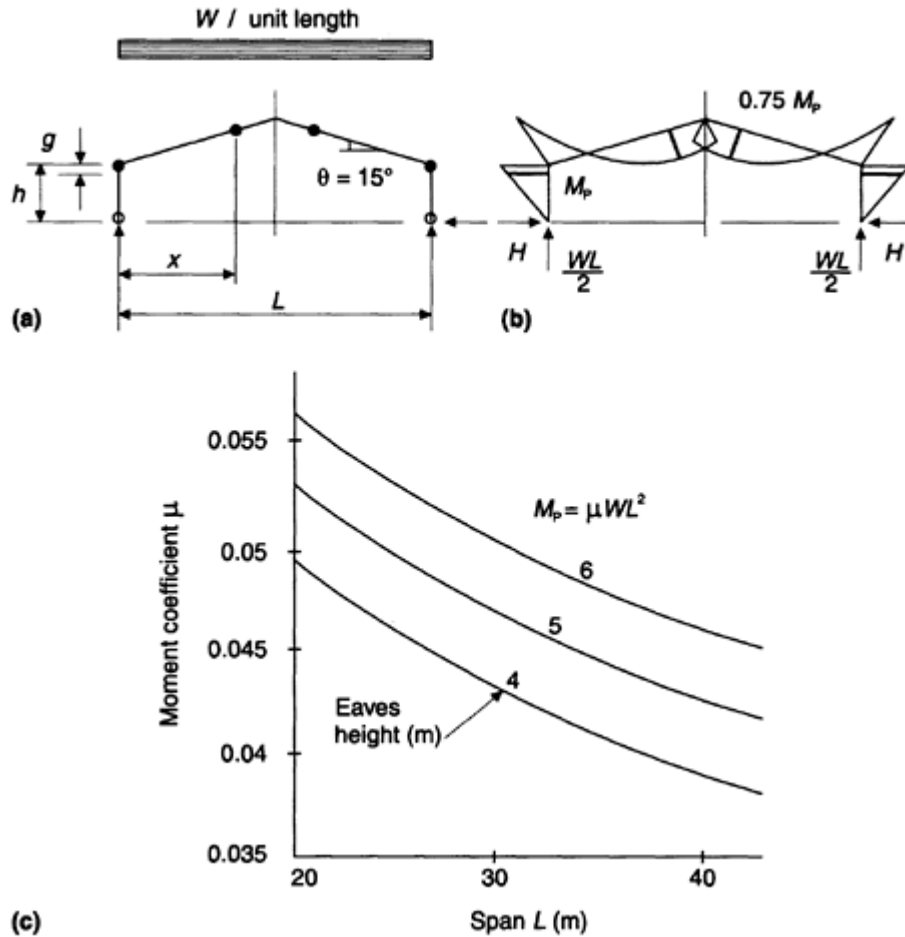

Fig. 3.4 Plastic analysis: (a) frame load and hinges; (b) plastic bending moments; (c) analysis chart.

It is more economical to use a lighter section for the rafter than for the column, rather than a uniform section throughout. The rafter is haunched at the eaves. This permits use of a bolted joint at the eaves and ensures that the hinge there forms in the column.

Let  $M_p$  be the plastic moment of resistance of the column and  $qM_p$  be the plastic moment of resistance of the rafter, where  $q=0.75$  for chart. Then

$$\begin{aligned} \text{Column hinge } M_p &= H(h - g) \\ \text{Rafter hinge } qM_p &= qH(h - g) \\ &= \frac{wLx}{2} - wx^2 - H(h + x \tan \phi) \end{aligned}$$

where

$w$ =roof load per unit length;

$L$ =span;

$H$ =horizontal reaction;

$h$ =eaves height;

$g$ =depth of column hinge below intersection of column and rafter centrelines (0.3–0.5 m for chart);

$\Phi$ =roof slope ( $15^\circ$  for chart);

$x$ =distance of rafter hinge from support.

Equate  $dH/dx=0$ , solve for  $x$  and obtain  $H$  and  $M_p$ .

A chart is given in Figure 3.4(c) to show values of the column plastic moment  $M_p$  for various values of span  $L$  and eaves height  $h$ .

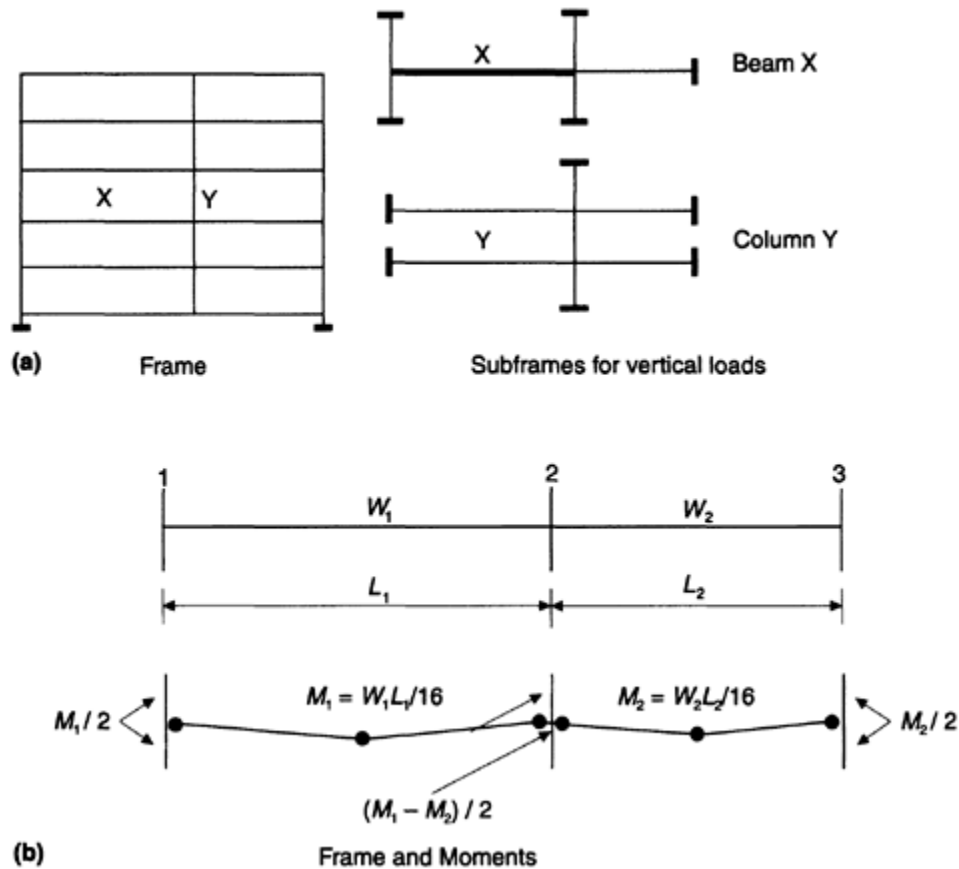

Fig. 3.5 Multistorey frames: (a) elastic analysis; (b) plastic analysis.

(d)

*Multistorey frames subjected to vertical loads*

Elastic and plastic methods are given.

- Elastic analysis—the subframes given in Clause 5.6.4.1 and Figure 11 of BS 5950 can be used to determine actions in particular beams and columns (Figure 3.5(a)). The code also enables beam moments to be determined by analysing the beam as continuous over simple supports.
- Plastic analysis—the plastic moments for the beams are  $\pm WL/16$ . The column moments balance the moment at the beam end as shown in Figure 3.5(b) and hinges do not form there. This analysis applies to a braced frame.

(e)

*Multistorey frames subjected to horizontal loads*

The following two methods were used in the past for analysis of multistorey buildings.

#### (i) Portal method

The portal method is based on two assumptions.

- The points of contraflexure are located at the centres of beams and columns.
- The shear in each storey is divided between the bays in proportion to their spans. The shear in each bay is then divided equally between the columns.

The column end moments are given by the product of the shear by one-half the storey height. Beam moments balance the column moments. External columns only resist axial force, which is given by dividing the overturning moment at the level by the building width. The method is shown in Figure 3.6.

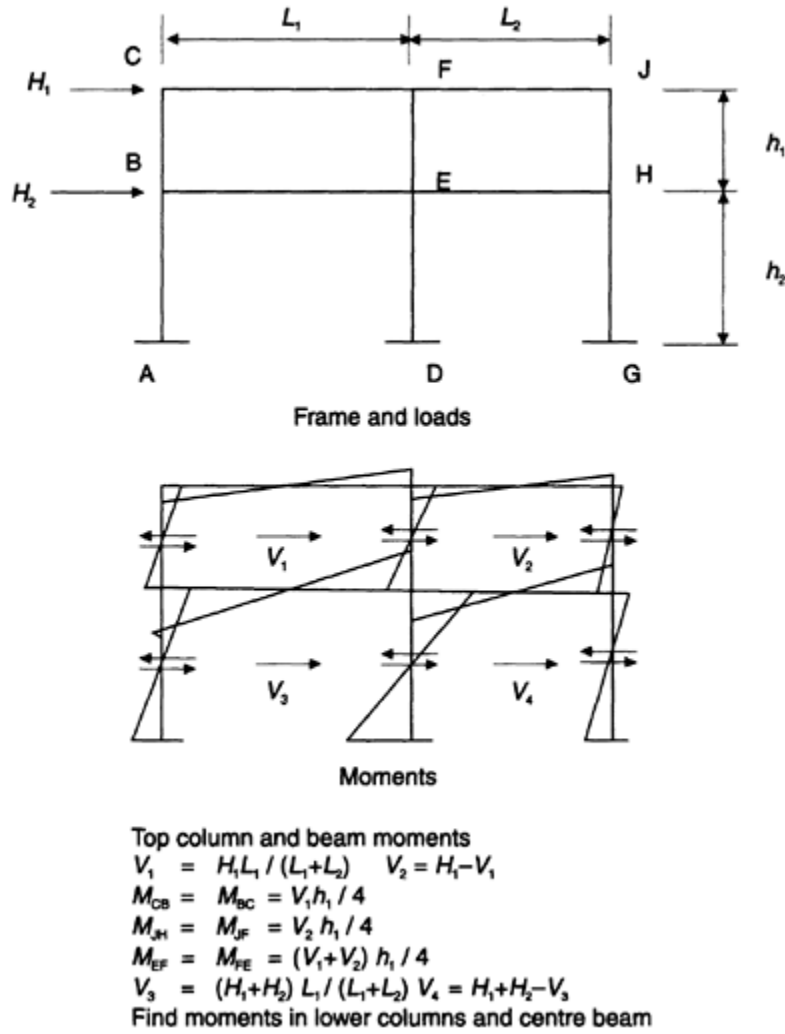

Fig. 3.6 Portal method.

**(ii) Cantilever method**

In the cantilever method, two assumptions are also made.

- The axial forces in the columns are assumed to be proportional to the distance from the centre of gravity of the frame. The columns are to be taken to be of equal area.
- The points of contraflexure occur at the centres of the beams and columns.

The method is shown in [Figure 3.7](#).

3.5  
ELEMENT DESIGN

**3.5.1  
General comments**

Element design is the process of sizing sections to resist actions obtained from analysis. Member design is required for members subjected to:

- axial load—ties, struts;
- bending and shear—beams with fully supported and unsupported compression flanges (universal beams, built-up sections, lattice girders and composite sections);

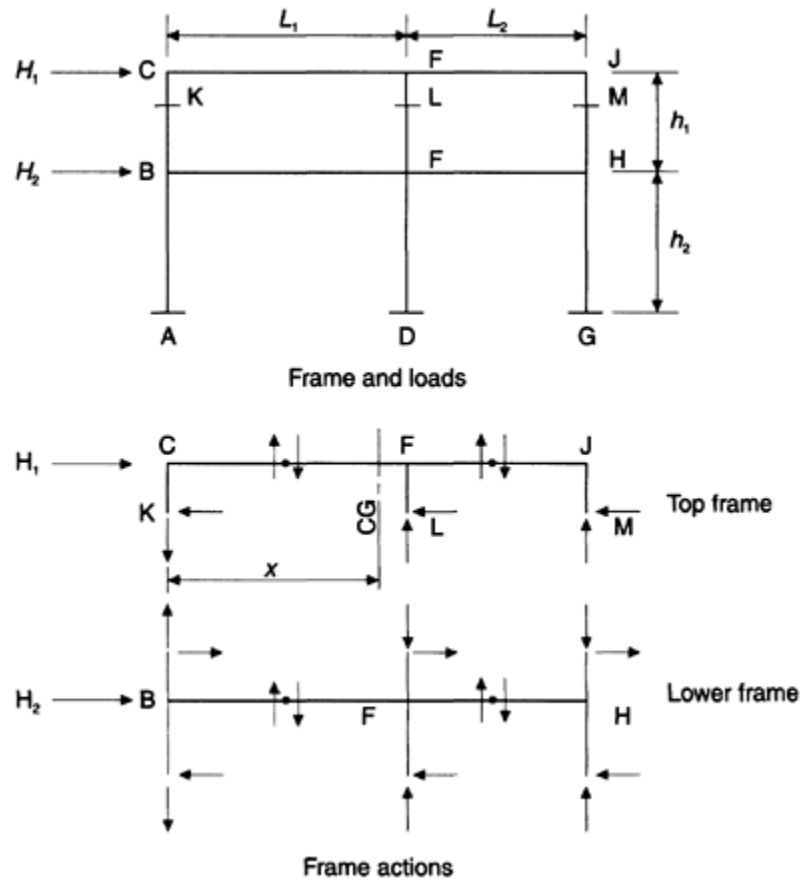

Actions in top frame  
 Calculate centre of gravity of columns  $x$   
 Express column forces in terms of  $R$ , e.g. at  $K=xR$   
 Take moments about  $K$ ,  $\Sigma M=0$ , solve for  $R$   
 Obtain column forces and beam shears  
 Take moments about beam centres, obtain column shears  
 Calculate top frame moments  
 Similarly find actions in lower frame

Fig. 3.7 Cantilever method.

- axial load and bending—beam-columns to be designed for local capacity and overall buckling.

### 3.5.2 Ties and struts

#### (a) Ties

Section size is based on the effective area allowing for bolt holes, defined in Clause 3.3.3 of BS 5950. Certain commonly used sections may be selected from load capacity tables (Steel Construction Institute, 1987).

#### (b) Struts and columns

The load capacity depends on the cross-sectional area, effective length and least radius of gyration. Certain commonly used sections may be selected directly from capacity tables in the handbook cited above.

Estimation of effective length of a member is important. This depends on whether ends are held in position or sway can occur and how effectively the ends are restrained in direction (BS 5950, Table 24 and Appendices D and E).

If sway is prevented, the effective length ( $l$ ) is equal to or less than the actual length ( $L$ ). If sway occurs, it is greater. The effective lengths for members in some common situations are shown in Figures 3.8 and 3.9.

The following applies for a rectangular multistorey building:

- frame braced in both directions, simple design  $-l=0.85L$ ;
- frame braced in both directions—rigid in transverse direction, simple in longitudinal direction  $-l_x=0.7L$ ,  $l_y=0.85L$ ;
- frame unbraced in transverse direction, braced in longitudinal direction  $-l_x>L$ ,  $l_y=0.85L$ .

Here  $l_x$  is the transverse effective length (X–X axis buckling);  $l_y$  is the longitudinal effective length (Y–Y axis buckling);  $L$  is the column length.

The capacities in axial load for some commonly used universal column sections are shown in Figure 3.10. Capacities for sections at upper and lower limits of serial sizes only are shown.

### 3.5.3 Beams and girders

#### (a) Universal beams

If the compression flange of the beam is fully restrained or the unsupported length is less than  $30r_y$  where  $r_y$  is the radius of gyration about the minor axis, the beam will reach its full plastic capacity. Lateral torsional buckling reduces the capacity for longer unsupported compression flange lengths.

For a beam with unsupported compression flange, the effective length depends on:

- spacing of effective lateral restraints;
- end conditions, whether the end is torsionally restrained or the compression flange is laterally restrained or if it is free to rotate in plan;
- whether the load is destabilizing; if so, the effective length is increased by 20%.

Refer to BS 5950, Section 4.3.

The *Steel Designers Manual* (1986, 1994) gives tables of buckling resistance moments for beams for various effective lengths. A design chart giving buckling resistance moments for some sections is shown in Figure 3.11.

#### (b) Plate girders

The simplified design method given in BS 5950, Section 4.4.4.2, is used where the flanges resist moment and the web shear. For a restrained compression flange (Figure 3.12):

$$\text{Flange area } bT = M/Dp_y$$

$$\text{Web thickness } t = V/q_{cr}d$$

where

$M$ ,  $V$ =applied moment, shear;

$D$ ,  $d$ =overall depth, web depth;

$T$ ,  $t$ =flange thickness, web thickness;

$b$ =flange width;

$p_y$ =design strength;

$q_{cr}$ =critical shear strength (depends on  $d/t$  and stiffener spacing—see Table 19 of BS 5950)

#### (c) Lattice girders

Suitable members can be selected from load capacity tables (Steel Construction Institute, 1987). Lattice girders are analysed in Section 3.4.1 (C) (Figure 3.1(b)).

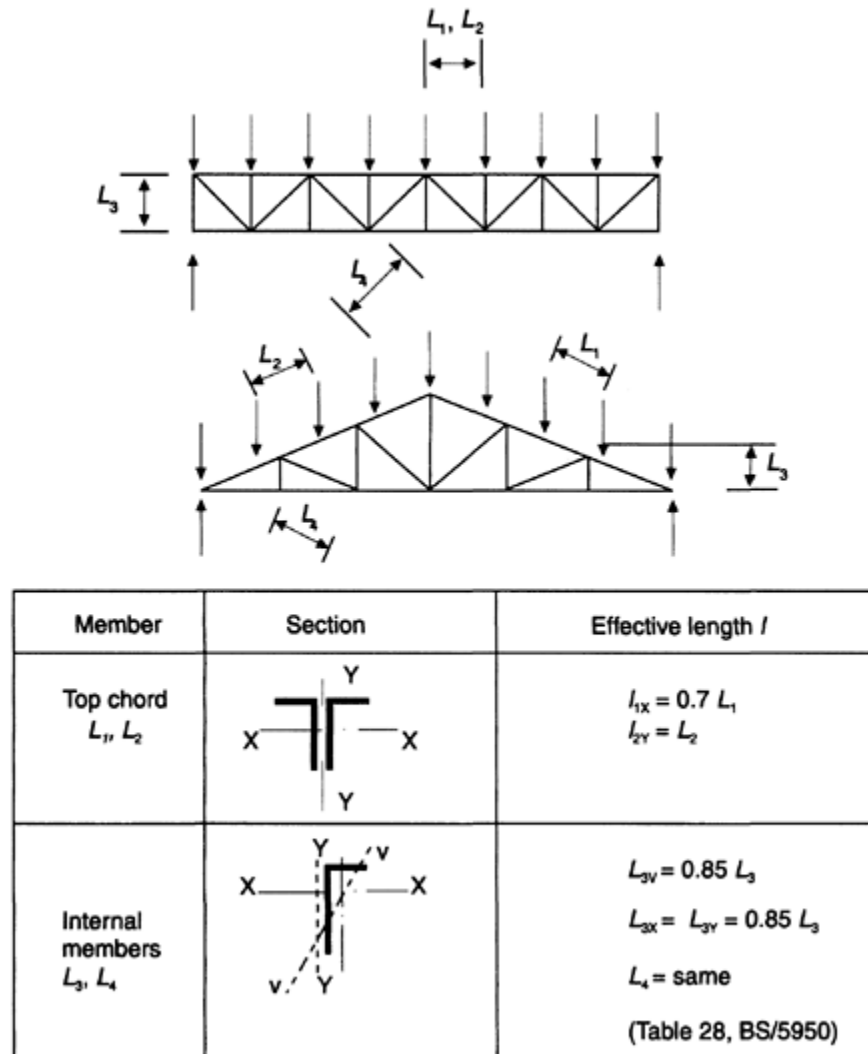

Fig. 3.8 Effective length for lattice girder and truss members.

### 3.5.4

#### Beam-columns

The beam-column in a multistorey rigid frame building is normally a universal column subjected to thrust and moment about the major axis. A section is checked in accordance with BS 5950, Section 4.8.3, using the simplified approach.

- Local capacity at support:

$$\frac{F}{A_g p_y} + \frac{M_x}{M_{cx}} \leq 1$$

- Overall buckling:

$$\frac{F}{A_g p_c} + \frac{m M_x}{M_b} \leq 1$$

where

$F, M_x$ =applied load, applied moment;

$A_g$ =gross area;

$p_y, p_c$ =design strength, compressive strength;

$M_{cx}$ =plastic moment capacity;

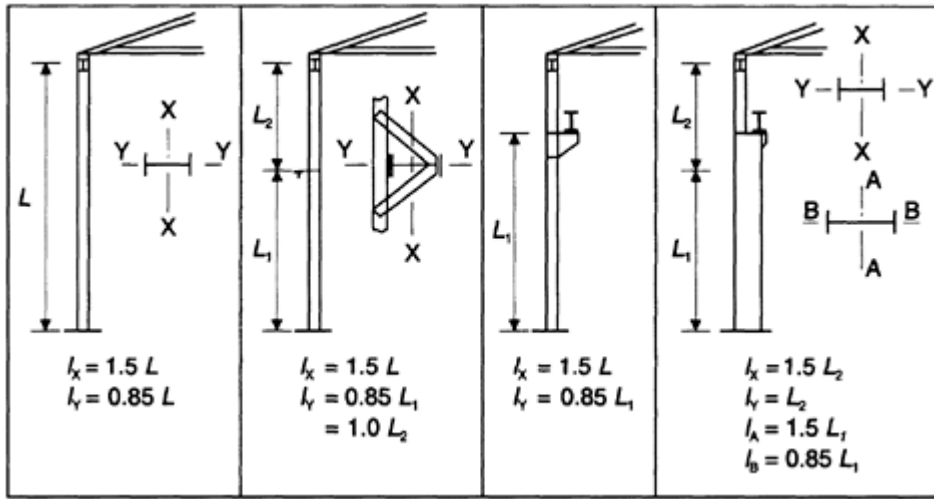

Fig. 3.9 Effective lengths for side stanchions in single-storey buildings.

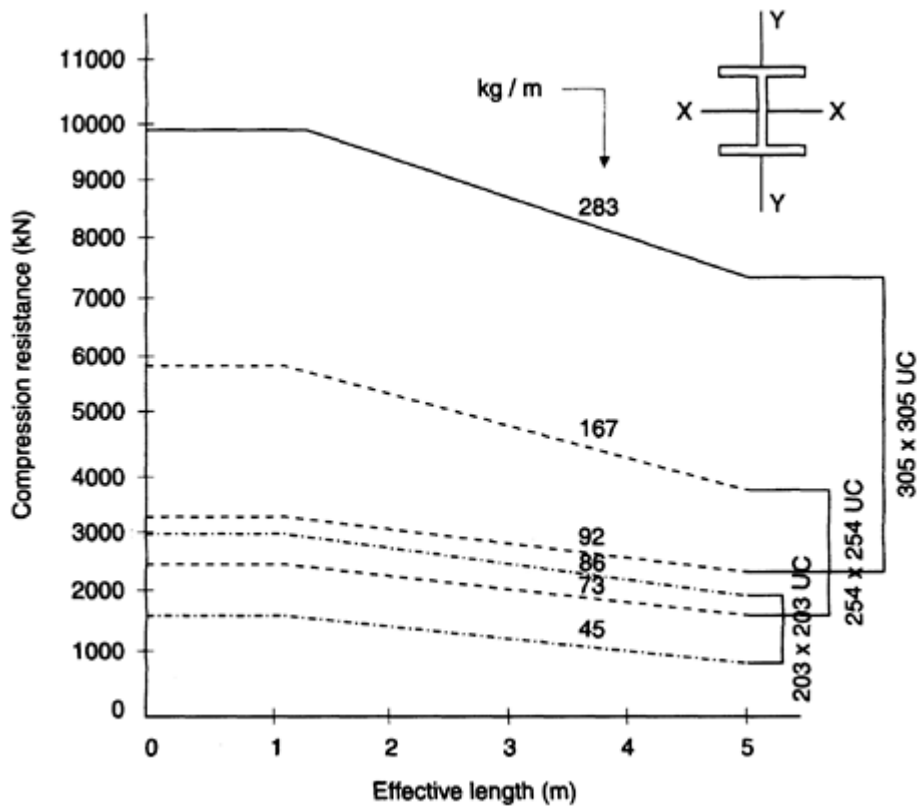

Fig. 3.10 Compression resistance—Y-Y axis buckling.

$M_b$ =buckling resistance moment;  
 $m$ =equivalent uniform moment factor.

Resistance and capacity tables are given in Steel Construction Institute (1987). Interaction charts for local capacity and overall buckling can be constructed for various sections for particular values of effective length (Figure 3.13).

### 3.5.5 Members in portal frames

Members in portal frames designed to plastic theory are discussed. The column is sized for the plastic hinge moment and axial load at the eaves. About 90% of capacity is required to resist moment. Lateral restraints must be provided at the hinge and within a specified distance to ensure that the hinge can form.



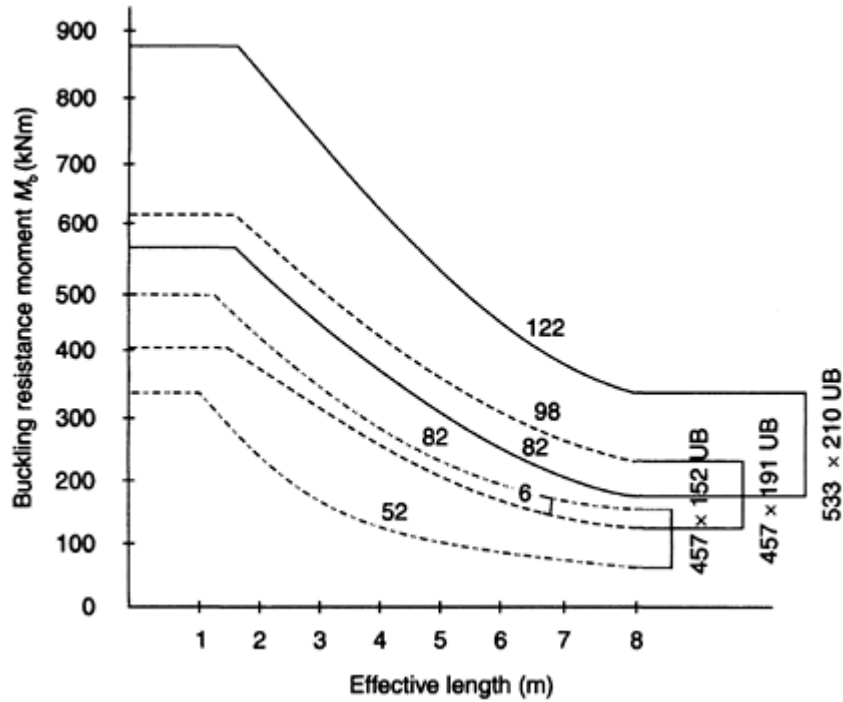

Fig. 3.11 Buckling resistance moment—conservative approach.

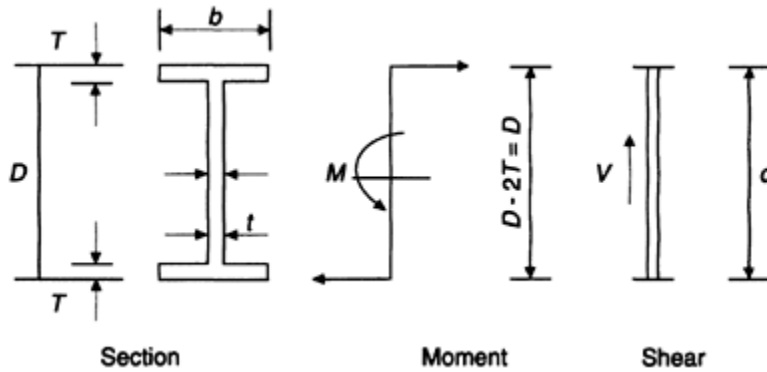

Fig. 3.12 Plate girder.

In the rafter, a haunch at the eaves ensures that part remains elastic. The hinge forms near the ridge, and restraints to the top flange are provided by the purlins.

Provisions for plastic design of portals are shown in Figure 3.14 detailed design is given in Section 4.2.

### 3.6 EXAMPLES

#### 3.6.1 Ribbed dome structure

##### (a) Specification

A kiosk required for a park is to be hexagonal in plan on a 16 m diameter base, 3 m high at the eaves and 5 m at the crown (Figure 3.15). There are to be three braced bays with brick walls. The roof is felt on timber on purlins with ceiling.

Deal load=1.0 kN/m<sup>2</sup> on slope

Imposed load=0.75 kN/m<sup>2</sup> on plan

Design using 3 No. three-pinned arches as shown in the figure, steel grade 50. For thickness <16 mm,  $p_y=355 \text{ N/mm}^2$ .

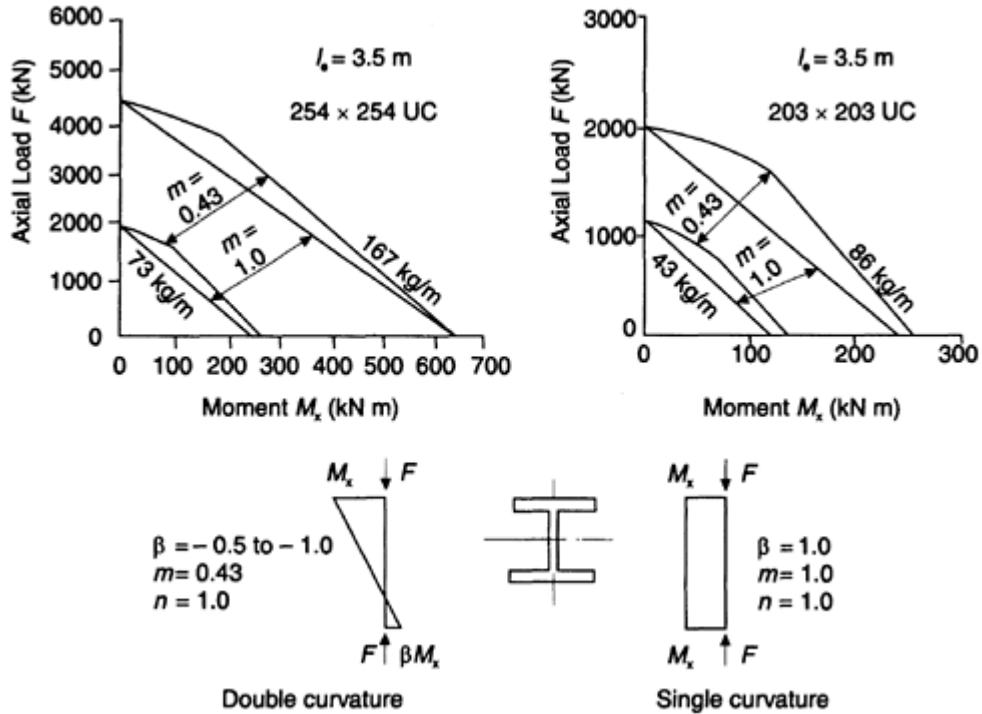

Fig. 3.13 Beam-column interaction charts for local capacity/overall buckling.

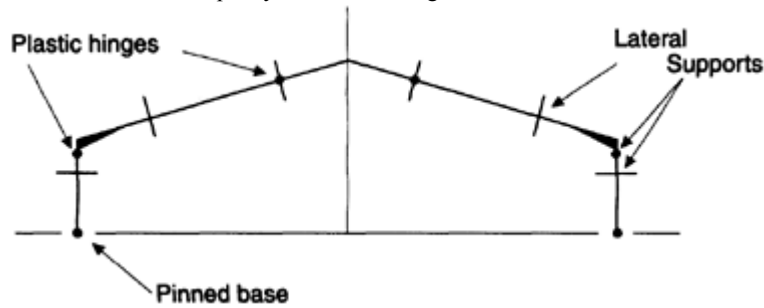

Fig. 3.14 Plastic-designed portal.

(b)  
Analysis and design

Design load =  $1.4/\cos 14^\circ + 1.6 \times 0.75 = 2.64 \text{ kN/m}^2$       Roof load on half portal =  $8^2(\cos 30^\circ) \frac{2.64}{2} = 73.2 \text{ kN}$       Reaction  $H = 73.2 \times 8 / 3 \times 5 = 39 \text{ kN}$       Moment  $M_B = 39 \times 3 = 117 \text{ kNm}$       Axial load in BC =  $73.2 \sin 14^\circ + 39 \cos 14^\circ = 55.5 \text{ kN}$

The maximum sagging moment is shown.

Assume eaves moment to be 85% of section capacity  $S_x$ :

$$S_x \text{ required} = 117 \times 10^3 / (355 \times 0.85) = 387 \text{ cm}^3$$

Select  $250 \times 150 \times 6.3 \text{ RHS}$ , for which  $S_x = 405 \text{ cm}^3$ .

A rigorous check can be made using Lee *et al.* (1981). This gives the out-of-plane effective lengths for the column as  $2.6 L_{BA}$  and for the rafter as  $1.4 L_{BC}$ . The moment is 81% of section capacity and the axial load in the rafter is 9%. The section must be adequately supported laterally.

### 3.6.2 Two-pinned portal—plastic design

(a)  
Specification (Figure 3.16(a))

Span 30 m, eaves height 5 m, roof slope 15°, spacing 6 m. Dead load 0.5 kN/m<sup>2</sup>, imposed load 0.75 kN/m<sup>2</sup>. Steel grade 43. Determine sections for the portal.

(b)  
Analysis and design

$$\text{Design load} = (1.4 \times 0.5 + 1.6 \times 0.75) \times 6 = 11.4 \text{ kN/m}$$

The portal rafter is to have 75% of the moment capacity of the columns. From Figure 3.4,

$$\text{Column: moment } M_{pc} = 0.047 \times 11.4 \times 30^2 = 482.2 \text{ kNm} \quad \text{axial load } F = 11.4 \times 15 = 171 \text{ kNm}$$

$$\text{Rafter: moment } M_{pR} = 0.75 \times 482.2 = 361 \text{ kNm}$$

For moment resistance of 90% of moment capacity,

$$\text{Section resistance} = 482.2 / 0.9 = 536.1 \text{ kNm}$$

Try 533 × 210 UB 82, where  $A = 104 \text{ cm}^2$ ,  $S_x = 2060 \text{ cm}^3$ . Check:

$$\frac{171 \times 10}{275 \times 104} + \frac{482.2 \times 10^3}{275 \times 2060} = 0.91$$

Rafter:

$$S_x = 361.7 \times 10^3 / 275 = 1315 \text{ cm}^3$$

For

$$457 \times 191 \text{ UB } 67, S_x = 1470 \text{ cm}^3.$$

The lateral support system must be designed. Section 4.2 gives a complete design.

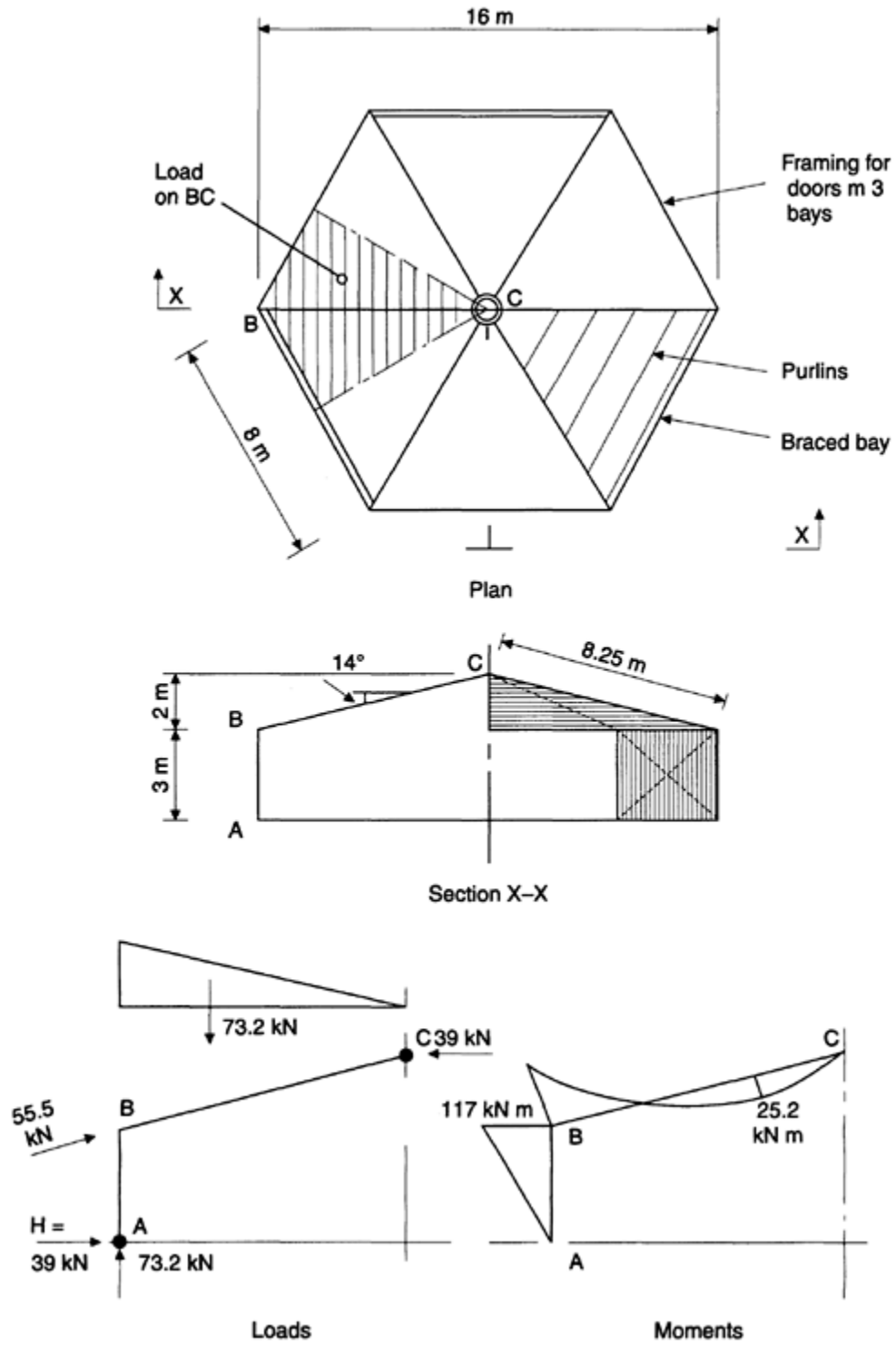

Fig. 3.15 Ribbed dome.

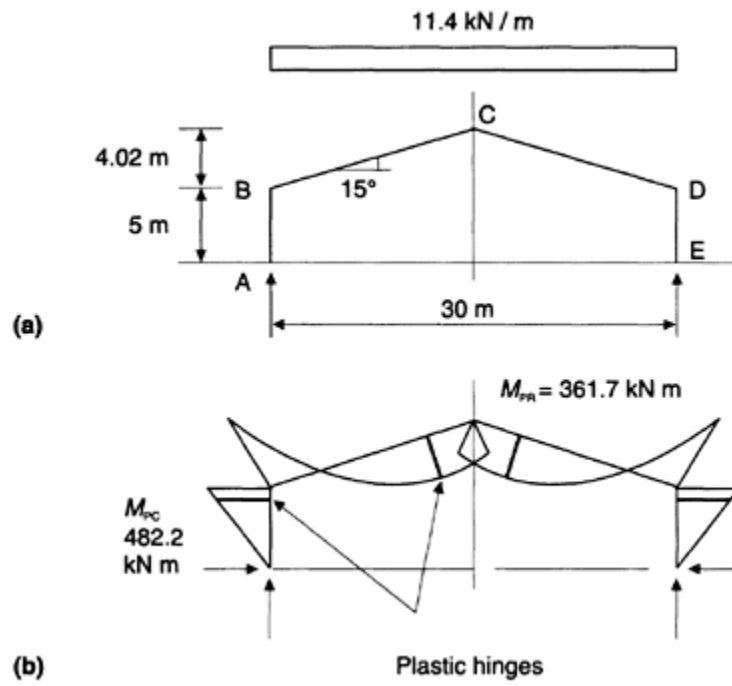

Fig. 3.16 Two-pinned portal: (a) elevation; (b) plastic moment diagram.

# CHAPTER 4

## Single-storey, one-way-spanning buildings

### 4.1 TYPES OF STRUCTURES

Some of the most important steel-framed buildings fall in the classification of single-storey, one-way-spanning structures. Types shown in [Figure 4.1](#) include:

- truss or lattice girder and stanchion frames;
- portals in various types of construction—
  - universal beams
  - built-up tapered sections
  - lattice;
- arches in single section or lattice construction.

The first type with pitched roof truss and cantilever columns included the historical mill building. It is still favoured for flat-roofed buildings using lattice girders. Portals now form the most popular building type for single-storey factories and warehouses. The pinned-base portal designed using plastic theory is almost exclusively adopted in the UK. In the USA, the built-up tapered section portal is commonly used. Arches are an architecturally pleasing and structurally efficient form of construction with a wide use including exhibition buildings and sports halls, warehouses etc.

Detailed designs are given for a pinned-base portal using plastic theory and a two-pinned arch using elastic theory. The portal is designed using universal beam sections. Two designs are given for the arch—one using rectangular hollow sections and one lattice construction.

The design of a portal constructed from built-up tapered sections is outlined briefly.

### 4.2 PINNED-BASE PORTAL—PLASTIC DESIGN

#### 4.2.1 Specification and framing plans

The portal has a span of 40m, height at eaves 5m and roof slope  $15^\circ$ . The portal spacing is 6 m and the building length is 60 m. The location is an industrial estate on the outskirts of a city in the north-east of the UK. The framing plans are shown in [Figure 4.2](#). The material is Grade 43 steel.

Standard universal beam portal construction is adopted. The haunched front at the eaves is shown in the figure. The frame is of simple design longitudinally with braced bays at each end. Purlins and sheeting rails are cold-rolled sections.

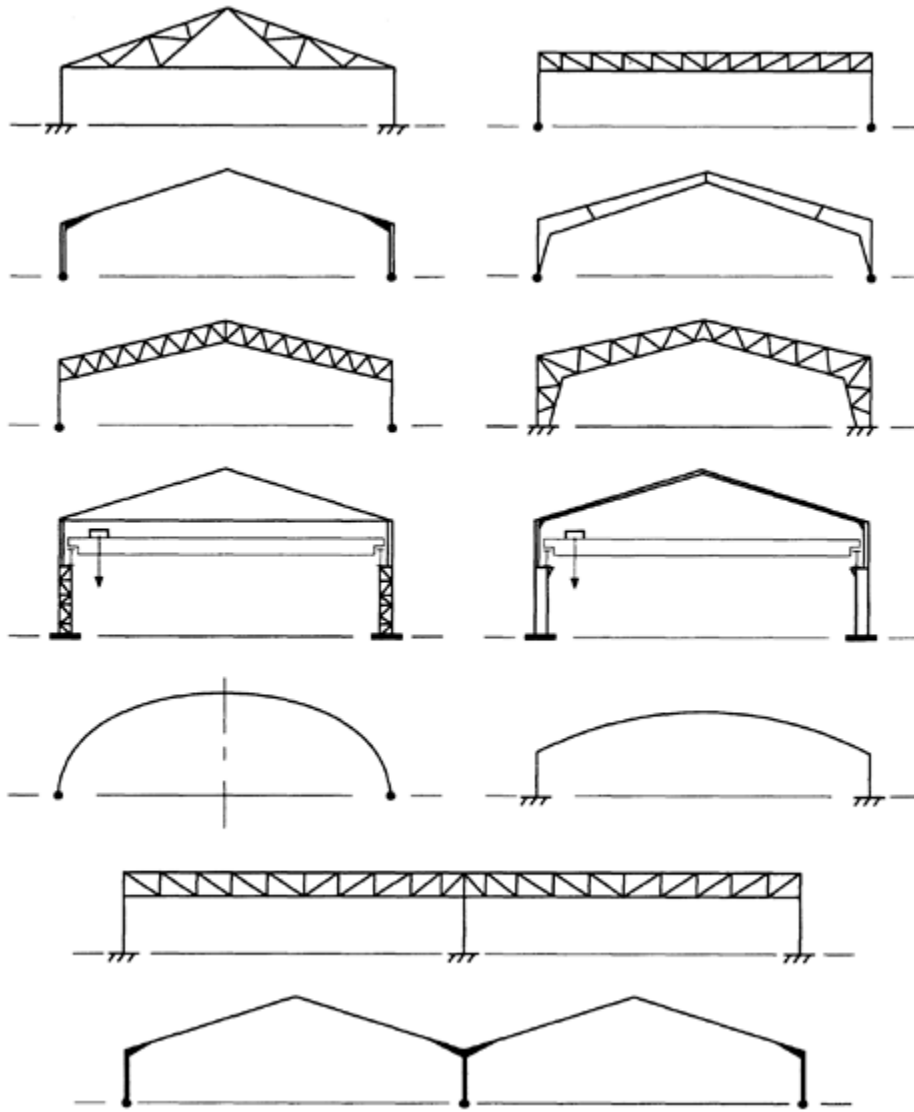

Fig. 4.1 Single-storey, one-way spanning buildings.

#### 4.2.2 Dead and imposed loads

(a)  
Dead load

Sheeting	= 0.1 kN/m <sup>2</sup>
Insulation	= 0.1
Purlins	= 0.05
Rafter	= 0.15
<hr/>	
Total	= 0.4 kN/m <sup>2</sup> on slope
	= 0.41 kN/m <sup>2</sup> on plan

Therefore

$$\text{Load on roof} = 0.41 \times 6 = 2.46 \text{ kN/m}$$

$$\text{Walls} = 0.4 \times 5 \times 6 = 12 \text{ kN}$$

The dead load is shown in Figure 4.3(a).

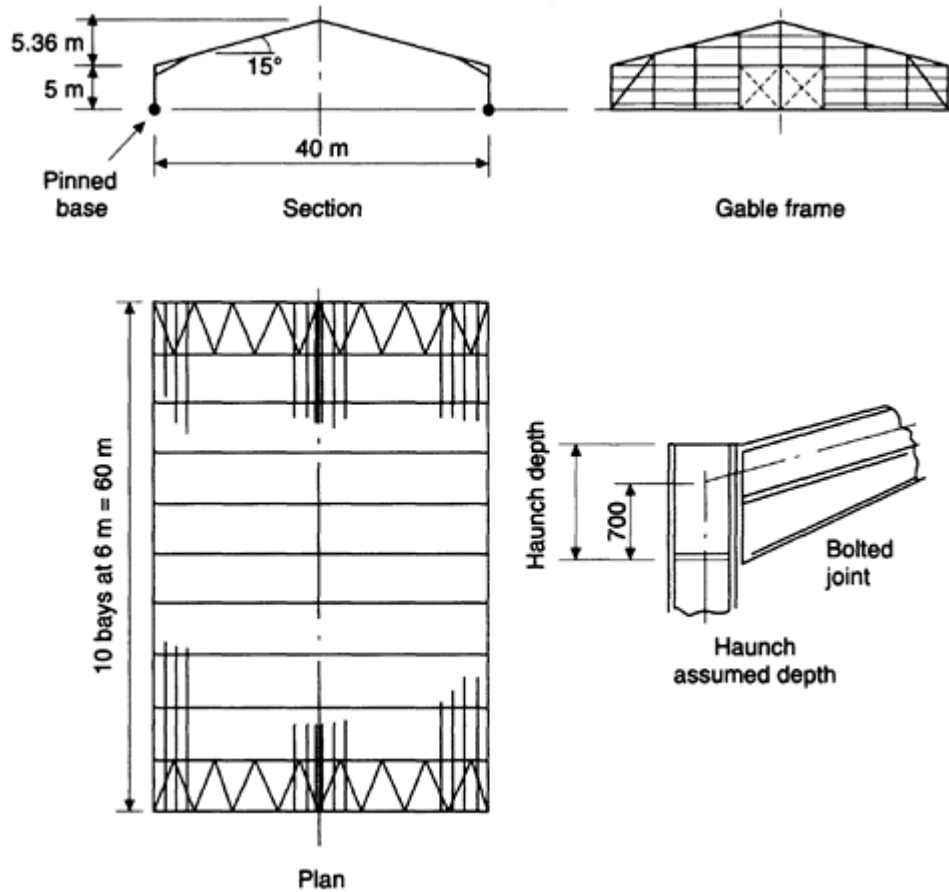

Fig. 4.2 Framing plans.

(b)

Imposed load

Imposed load from BS 6399: Part 1 =  $0.75 \text{ kN/m}^2 = 4.5 \text{ kN/m}$  on roof This is shown in Figure 4.3 (b).

Note that the purlin load is  $0.95 \text{ kN/m}^2$ . For purlin centres 1.5 m, select Wara Multibeam A170/170 purlins with a safe load of  $1.19 \text{ kN/m}^2$ .

### 4.2.3

#### Wind loads

The wind load is in accordance with BS 6399: Part 2.

(a)

Location of buildings

Outskirts of city in NE England on an industrial estate with clear surroundings, 10 km to sea and 75 m above sea level.

(b)

Building dimensions

Plan  $60 \text{ m} \times 40 \text{ m}$ ; height to eaves 5 m, to rooftop 10.36 m (Figure 4.2).

(c)

Building data—Sections 1.6 and 1.7 of code

Building type factor: for portal sheet,  $k_b = 2$  (Table 1).



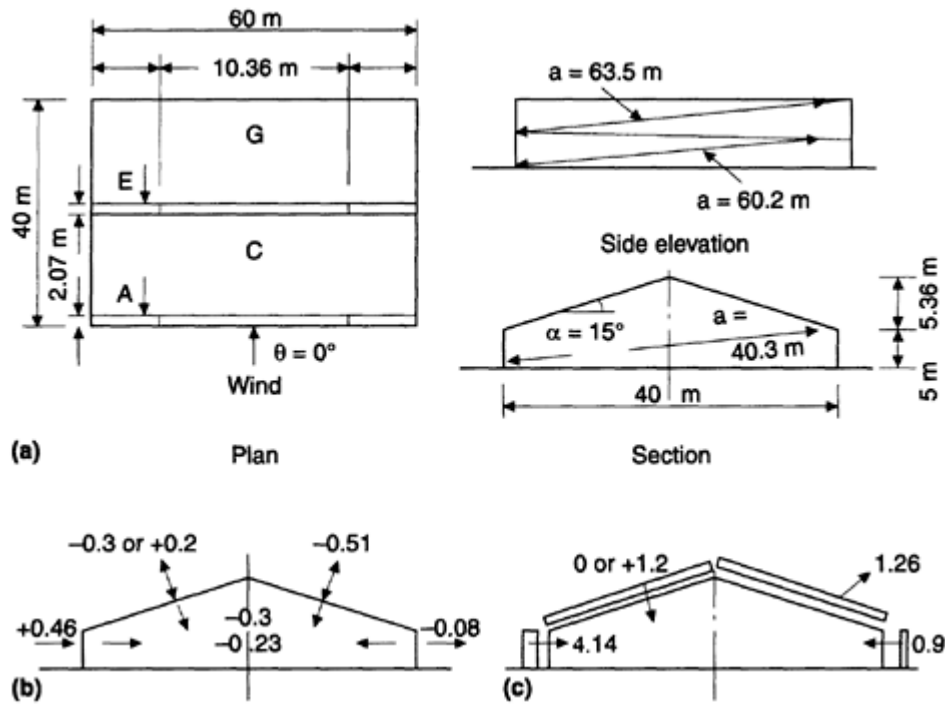

Fig. 4.3 Transverse wind loads: (a) dimensions; (b) external and internal pressures (kN/m<sup>2</sup>); (c) net member loads (kN/m<sup>2</sup>).

Reference height  $H_r = 10.36 \text{ m} = H$

Dynamic augmentation factor  $C_r = 0.05$  (Figure 3)

(d)

Wind speed—Section 2.2 of code

Basic wind speed  $V_b = 25 \text{ m/s}$  (Figure 6)

Site wind speed  $V_s = V_b S_a S_d S_s S_p$

where

Sea-altitude factor  $= 1.001 \Delta_s = 1.075$ ,  $\Delta_s = 75 \text{ m}$

$S_d = 1.0$  (Table 3)

$S_s = S_p = 1.0 =$  Seasonal and probability factors

Therefore

$V_s = 1.075 \times 25 = 26.9 \text{ m/s}$

Effective wind speed  $V_e = V_s S_b$

where

$S_b =$  terrain and building factor (Table 4)

$= 1.45$  for walls,  $1.7$  for roof

$V_e = 39 \text{ m/s}$  for walls,  $45.7 \text{ m/s}$  for roof

(e)

Transverse wind load—Section 2.1 of code

Dynamic pressure  $q_s = 0.613 V_e^2 / 10^3 \text{ kN/m}^2$

Walls:  $q_s = 0.93 \text{ kN/m}^2$ ; roof:  $q_s = 1.25 \text{ kN/m}^2$

External pressure coefficients  $C_{pe}$  are as follows.

- Wall (code, Section 2.4, Table 5),  $D/H = 40/874$ . For windward wall,  $C_{pe} = +0.6$ ; leeward wall,  $C_{pe} = -0.1$ .
- Roof (code, Section 2.5). From Figure 4.3(a),  $\theta = 0^\circ$ ,  $\alpha = +15^\circ$ ,  $b_L = 2H = 20.72 \text{ m}$ . From code, Table 10 for duopitch roofs,  $C_{pe}$  values for A:  $-1.302 + 0.2$ ; C:  $-0.3$  or  $+0.2$ ; E:  $-1.1$ ; G:  $-0.5$ . Use uplift value for C (negative) and G in analysis.

The internal pressure coefficient  $C_{pi}$  (code, Section 2.6), for four walls equally permeable, is  $-0.3$  (Table 16).

Size effect factors  $C_a$  (Clause 2.1.3.4, Figure 4) for  $H > 10\text{--}15 \text{ m}$ ,  $B = 10 \text{ km}$  to sea are (Figure 4.3(a)):

- walls:  $a = 60.2 \text{ m}$ ,  $C_a = 0.82$  (Curve B);
- roof:  $a = 63.5 \text{ m}$ ,  $C_a = 0.81$ .

The internal and external pressures are shown in Figure 4.3(b):

$$\text{External surface pressure } p_e = q_s C_{pe} C_a \quad \text{Internal surface pressure } p_i = q_s C_{pi} C_a \quad \text{Net pressure } p = p_e - p_i$$

The net member loads ( $=6p$  kN/m) are shown in Figure 4.3(c).

Note that in accordance with Clause 2.1.3.6, the overall horizontal loads could be reduced by the factor  $0.85(1+C_r)$  where  $C_r$  is the dynamic augmentation factor. This reduction will not be applied in this case.

(f)  
*Longitudinal wind loads* (Figure 4.4)

The high values of the external pressure coefficients in the edge strips on the walls and roof will be taken into account. The windward end is taken to be permeable to give internal pressure. The portal frame X next to the windward end subject to the highest uplift load is analysed.

$$a=40.3 \text{ m}, c_a=0.85 \text{ (Figure 4, Curve B)}$$

External pressure coefficients  $C_{pe}$  are as follows.

- Walls,  $b=B$  or  $2H=20.72$  m. The various zones are taken from Figure 12. For A,  $C_{pe}=-1.3$ ; for B,  $C_{pe}=-0.8$  (Table 5)
- Roof,  $b_w=W$  or  $2H=20.72$  m. The various zones are taken from Figure 20. For A,  $C_{pe}=-1.6$ ; for B,  $C_{pe}=-1.5$ ; for C,  $C_{pe}=-0.6$  (from Table 10 for roof angle  $\alpha=15^\circ$ ).

Internal pressure coefficient  $C_{pi}=+0.2$  (Table 16).

$$\text{Total pressure} = p_e + p_i = q_s C_a (C_{pe} + C_{pi})$$

$$\text{Wall load for frame X } (q_s=0.93 \text{ kN/m}^2) = 0.93 \times 1.5 \times 4.14 \times 0.85 \times 2.07/6 + 0.93 \times 1.0 \times 0.85 \times 1.86 \times 5.07/6 + 0.93 \times 1.0 \times 0.85 \times 3 = 1.69 + 1.24 + 2.37 = 5.3 \text{ kN/m}$$

Roof load for frame X ( $q_s=1.25$  kN/m<sup>2</sup>):

$$\text{Load for section A} = (1.25 \times 1.8 \times 2.07 \times 0.85) / 6 + (1.25 \times 0.8 \times 3.93 \times 0.85) / 6 + (1.25 \times 0.8 \times 4.36 \times 0.85) / 6 + (1.25 \times 0.5 \times 1.64 \times 0.85) / 6 = 0.69 + 2.25 + 2.36 + 0.12 = 5.42 \text{ kN/m}$$

$$\text{Load for section B} = (0.69 \times 1.7/1.8) + 2.25 + 2.36 + 0.12 = 5.38 \text{ kN/m}$$

The portal loads are shown in Figure 4.4. The analysis will be performed for a uniform wind load on the roof of 5.42 kN/m.

#### 4.2.4 Design load cases

(a)  
*Dead and imposed loads*

$$\text{Design load} = (1.4 \times \text{dead}) + (1.6 \times \text{imposed}) \quad \text{Roof: } (1.4 \times 2.46) + (1.6 \times 4.5) = 10.64 \text{ kN/m}$$

$$\text{Walls: } 1.4 \times 12 = 16.8 \text{ kN}$$

The design loads are shown in Figure 4.5(a).

(b)  
*Dead and wind loads*

Wind uplift is important in checking roof girder stability. Both cases, wind transverse ( $\theta=0^\circ$ ) with internal suction and wind longitudinal ( $\theta=90^\circ$ ) with internal pressure, are examined.

$$\text{Design load} = 1.4 \times \text{wind} - 1.0 \times \text{dead resisting uplift}$$

The characteristic wind loads for the two cases are shown in Figures 4.3 and 4.4. The design loads are shown in Figure 4.6.

#### 4.2.5 Plastic analysis and design

Plastic design is adopted for dead and imposed loads.

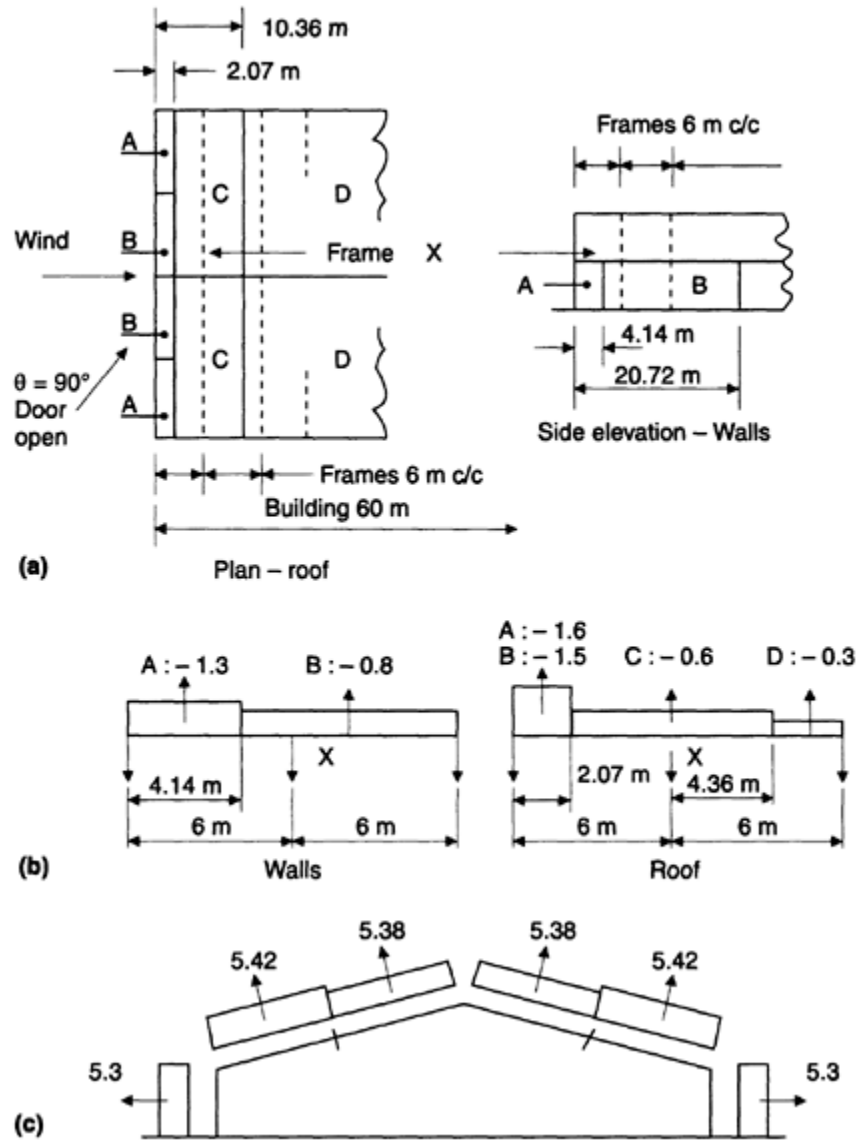

Fig. 4.4 Longitudinal wind loads: (a) dimensions; (b) external pressure coefficients; (c) member loads (kN/m).

(a)

Uniform portal

Collapse occurs when hinges form in the column at the bottom of the haunches and either side of the ridge. The hinges ensure that no hinges form in the rafter near the eaves (Figure 4.5(a)).

If the rafter hinge forms at  $x$  from the column, then the following two equations can be formed to give the value of the plastic moment:

$$\text{Column: } M_p = 4.3H$$

$$\text{Rafter: } M_p = 212.8x - 5.32x^2 - (5 + 0.27x)H$$

$$H = \frac{212.8x - 5.32x^2}{9.3 + 0.27x}$$

Put  $dH/dx=0$  to give equation

$$x^2 + 68.7x - 1375 = 0$$

Solve to give

$$x = 16.2 \text{ m}$$

From which

$$H = 150 \text{ kN}$$

$$\text{Plastic moment } M_p = 645 \text{ kNm}$$

$$\text{Plastic modulus } S_x = 645 \times 10^3 / 275 = 2346 \text{ cm}^3$$

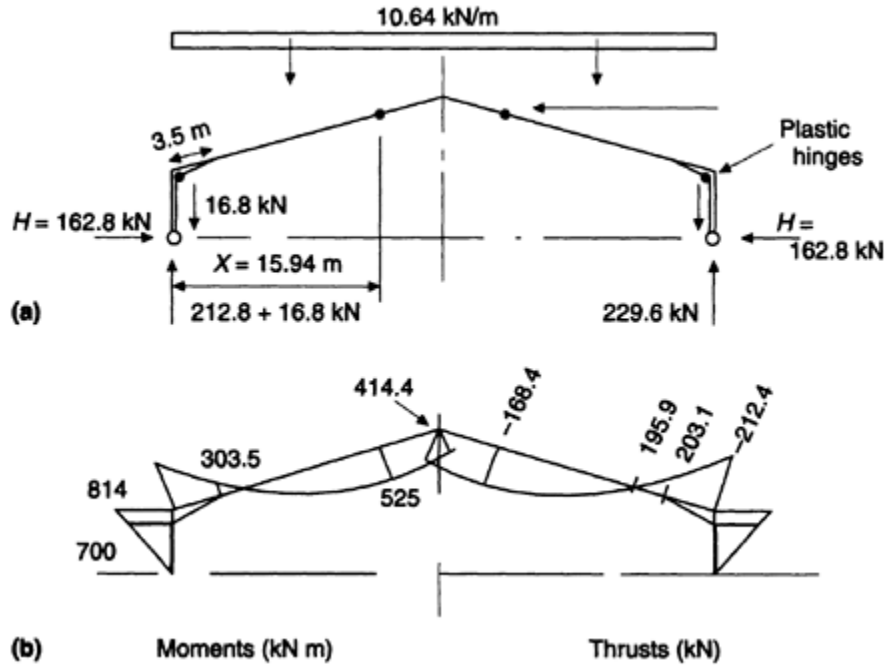

Fig. 4.5 Dead and imposed load—plastic analysis: (a) loads, reactions and hinges; (b) moments and thrusts.

Select 610×229 UB 101,  $S_x=2510 \text{ cm}^3$ ,  $T=15.6 \text{ mm}$ ,  $p_y=275 \text{ N/mm}^2$ . This allows for axial load in column.  
 This section would require further checks. The basic frame weight neglecting the haunch is 5/93 kg.

(b)  
 Non-uniform portal

Assume that the plastic bending capacity of the rafter is 75% that of the column. The equations for the plastic moments at the hinges can be rewritten to give

Column:  $M_p=4.3H$

Rafter:  $0.75M_p=212.8x-5.32x^2-(5+0.27x)H$

Then

$$H = \frac{212.8x - 5.32x^2}{8.23 + 0.27x}$$

Put  $dH/dx=0$  and solve to give  $x=15.9 \text{ m}$ ,  $H=162.8 \text{ kN}$ .

Column:  $M_p=700 \text{ kNm}$

$S_x=2545 \text{ cm}^3$

Select 610×229 UB 101,  $S_x=2880 \text{ cm}^3$ ,  $T=14.8 \text{ mm}$ ,  $p_y=275 \text{ N/mm}^2$ .

Rafter:  $M_p=0.75 \times 700=525 \text{ kNm}$

$S_x=1909 \text{ cm}^3$

Select 533×210 UB 82,  $S_x=2060 \text{ cm}^3$ .

Weight=4406 kg (neglecting haunches)

Figure 4.5(b) shows moments and thrusts at critical sections. Further checks are carried out below on the non-uniform frame.

4.2.6  
 Dead and wind loads

The stability of the rafter must be checked for possible uplift loads due to wind. The two wind load cases—wind transverse and wind longitudinal—acting with the dead loads are considered. Elastic analyses based on the sections obtained from the plastic design are carried out. The frame loads and bending moment diagrams are shown in Figure 4.6. For transverse wind, the zero wind load case on the windward rafter only is shown.

The stability check on the leeward girder for the wind transverse case is carried out in section 4.2.8.

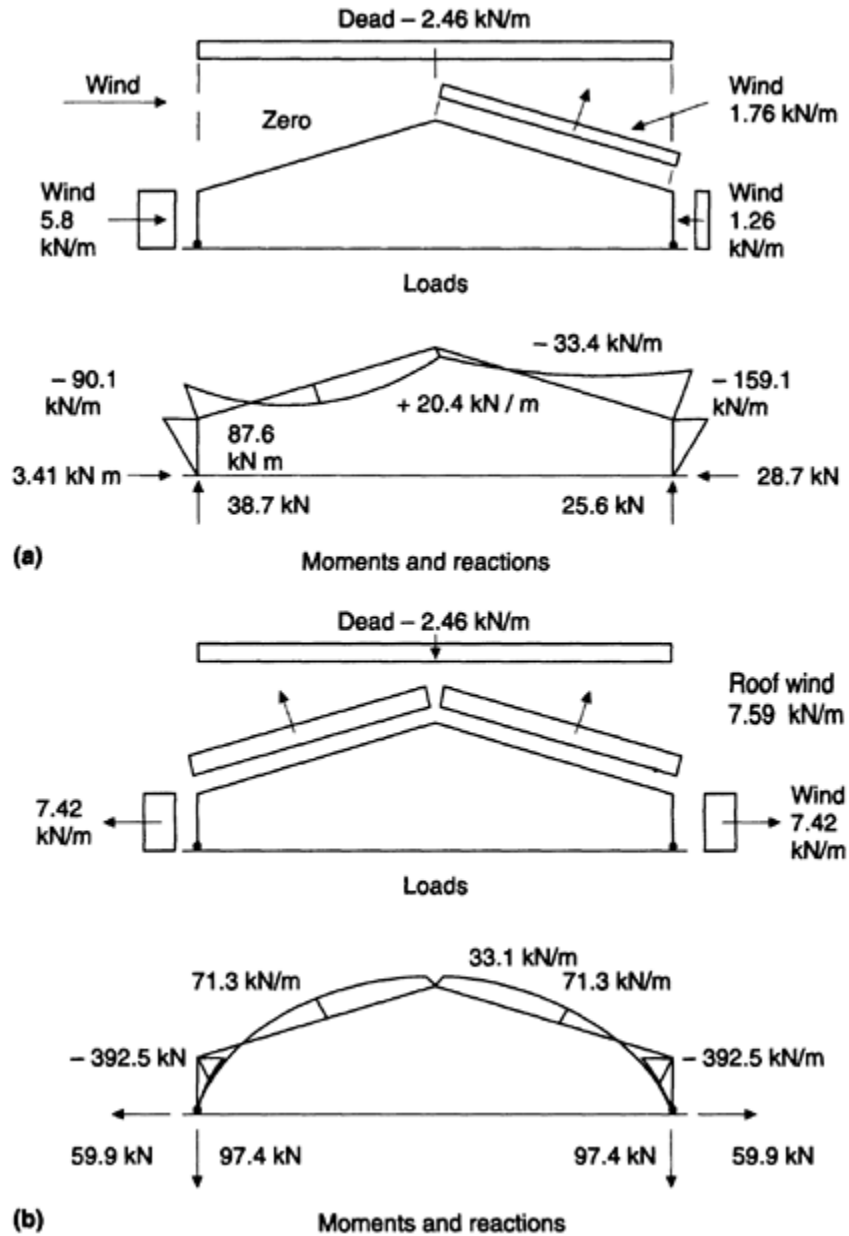

Fig. 4.6 Design wind loads: (a) transverse; (b) longitudinal.

### 4.2.7 Plastic design—checks

#### (a) Sway stability

Sway stability of the portal is checked using the procedure given in Clause 5.5.3.2 of BS 5950 where the following condition must be satisfied for Grade 43 steel:

$$\frac{L_D}{D} \leq \frac{44L}{\Omega h} \left( \frac{P}{4 + (PLr/L)} \right)$$

where

$$P = (2I_c I_r)(L/h)$$

in which  $I_c$ ,  $I_r$  are moments of inertia of the column and rafter —75700 cm<sup>3</sup> and 47500 cm<sup>3</sup>, L is the span—40m and h is the column height—5 m. Thus

$$P=(2 \times 75700 \times 40)/(47500 \times 5)=25.5$$

Also

Haunch depth=973.2 mm (Figure 4.2)

<2×rafter depth  $D=528.3$  mm

$L_D=L=40$  m

where  $W_r$  is the factored vertical load on the rafter (Figure 4.5(a)) and  $W_0$  is the load causing plastic collapse of rafter treated as fixed-ended beam of span 40 m.

$$\Omega = W_r/W_0$$

$$W_r = 40 \times 10.64$$

$$W_0 = \frac{275 \times 2060 \times 16}{10^3 \times 40} = 226.6 \text{ kN}$$

Thus

$$\Omega=40 \times 10.64/226.6=1.88$$

Finally

$$L_r=\text{developed length of rafter}=41.4 \text{ m}$$

Substituting into the code expression gives

$$\frac{40}{0.528} = 75.8 < \frac{44 \times 40}{1.88 \times 5} \left[ \frac{25.5}{4 + 25.5 \times 41.4/40} \right]$$

$$< 157.1$$

The portal is satisfactory with respect to sway stability.

(b)  
Column

**(i) Check capacity at hinge (Figure 4.5(a))**

$$M_p=700 \text{ kNm}$$

$$F=212.8+(0.97 \times 16.8/5)=216.1 \text{ kN}$$

The column uses 610×229 UB 101, with  $A=129 \text{ cm}^2$ ,  $S_x=2880 \text{ cm}^3$ ,  $r_x=24.2 \text{ cm}$ ,  $r_y=4.75 \text{ cm}$ ,  $u=0.863$ ,  $x=43.0$ .

From Steel Construction Institute (1987), Vol. 1, note 3.2.6) the axial load ratio is given by  $n=(216.1 \times 10)/(129 \times 275)=0.061$  <change value 0.468 Reduced  $S_r=2880-3950 \times 0.061^2=2865 \text{ cm}^3$  > $S_x$  required 2545  $\text{cm}^3$  column section is satisfactory.

**(ii) Column restraints and stability**

A torsional restraint is provided by stays from a sheeting rail at the plastic hinge in the column as shown in Figure 4.7. The distance to the adjacent restraint using the conservative method given in Clause 5.3.5(a) of BS 5950 is given by

$$L_m = \frac{38r_y}{\left[ (f_c/130) + (x/36)^2 \right]^{1/2}}$$

where

$$f_c=216.8 \times 10/129=16.8 \text{ N/mm}^2$$

Thus

$$L_m = \frac{38 \times 47.5}{\left[ (16.8/130) + (43/36)^2 \right]^{1/2}} = 1447 \text{ mm}$$

Place a sheeting rail and stays at 1400 mm below the hinge as shown in Figure 4.7.

The column is now checked between the second restraint and the base over a length of 2.9 m. Actions at the restraint shown on Figure 4.7 are

$$F=222.5 \text{ kN}$$

$$M=472.1 \text{ kNm}$$

In-plane:

$$l_{ex}=5.0 \text{ m}^*$$

$$\lambda_x=5000/242=20.6$$

Out-of-plane:

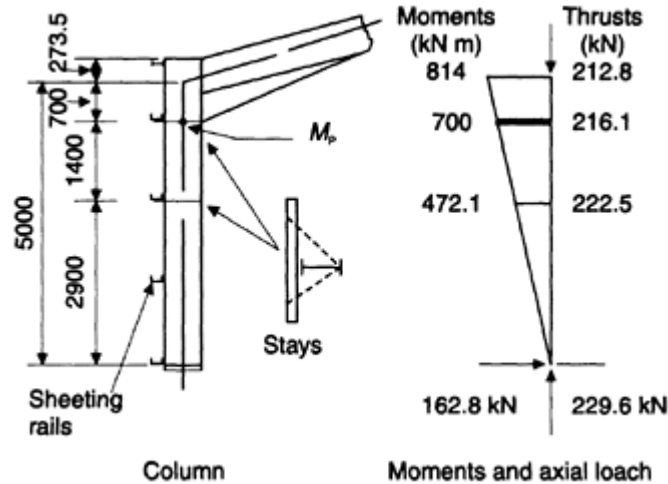

Fig. 4.7 Torsional column restraint.

$$\lambda_y = 2900/47.5 = 61.1 \quad p_c = 200.8 \text{ N/mm}^2 \text{ (Table 27)} \quad \lambda/x = 61.1/43 = 1.4 \quad V = 0.97 \text{ (Table 14)} \quad \lambda_{LT} = 0.863 \times 0.97 = 0.837 \quad p_b = 235.1 \text{ N/mm}^2 \quad M_b = 235.1 \times 288 / 10^3 = 677.1 \text{ kNm} \quad \beta = 0.0, m = 0.57 \text{ (Table 18)}$$

Combined—local capacity has been checked above.

Overall buckling:

$$\frac{222.5 \times 10}{200.8 \times 129} + \frac{0.57 \times 472.1}{677.1} = 0.31$$

The column section is satisfactory—adopt 610×229 UB 101.

(c)  
Rafter

(i) Check capacity at hinge (Figure 4.5(a))

$$M_p = 525 \text{ kNm}$$

$$F = 146 \text{ kN}$$

The rafter uses 533×210 UB 82, with  $A = 104 \text{ cm}^2$ ,  $S_x = 2060 \text{ cm}^3$ ,  $r_y = 4.38 \text{ cm}$ ,  $u = 0.856$ ,  $x = 41.6$ .

$n = (146 \times 10) / (104 \times 275) = 0.051 < \text{change value, } 0.458 \quad S_1 = 2060 - (2860 \times 0.0512) = 2053 \text{ cm}^3 > S_x \text{ required, } 1909 \text{ cm}^3$   
The rafter section is satisfactory.

(ii) Check stresses in haunch

The haunch length is normally made about one-tenth of the span. The proposed arrangement is shown in Figure 4.8, with a haunch 3.5 m long. This is checked first to ensure that the stresses remain elastic. The actions are shown in the figure.

At the beginning of the haunch the actions are

$$M = 763.8 \text{ kNm}$$

$$F = 211.5 \text{ kN}$$

(section AA in Figure 4.8). The flange of the UB is neglected but it supports the web. The properties are listed in Table 4.1.

From the table,  $A = 150.3 \text{ cm}^2$ ,  $Z_x = 4193 \text{ cm}^3$ . Thus maximum stress is given by

$$\frac{211.5 \times 10}{150.3} + \frac{763.8 \times 10^3}{4193} = 196.3 \text{ N/mm}^2$$

At the end of the haunch the actions are

$$M = 303.5 \text{ kNm}$$

$$F = 203.1 \text{ kN}$$

Maximum stress is given by

$$\frac{203.1 \times 10}{104} + \frac{303.5 \times 10^3}{1800} = 188.1 \text{ N/mm}^2$$

The stresses are in the elastic region.

\*Steel Construction Institute (1987, Vol. 2, portal design example).

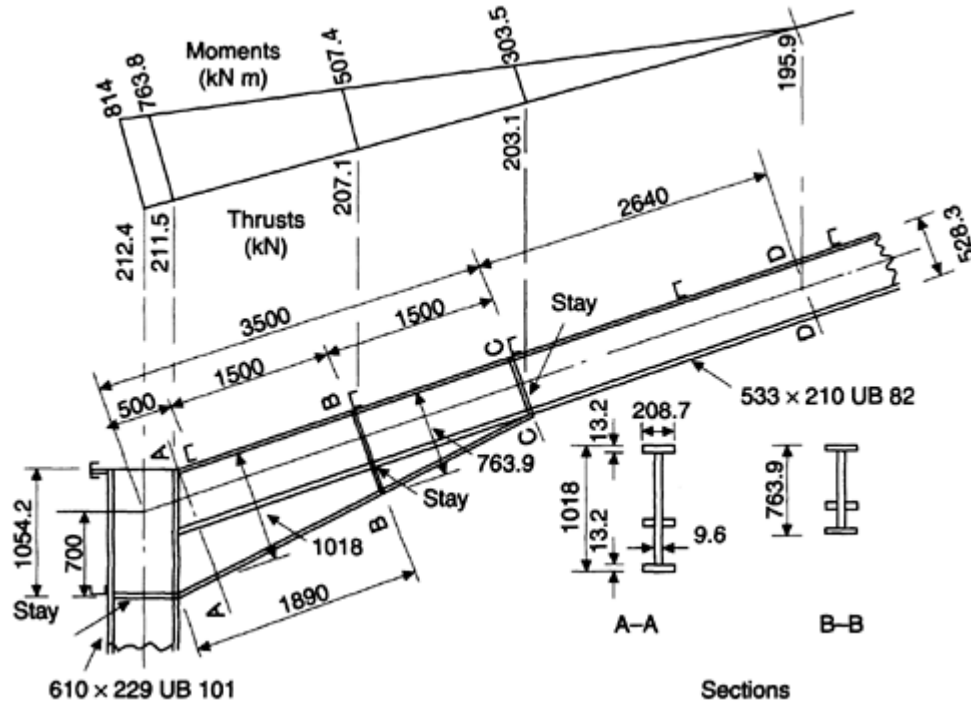

Fig. 4.8 Haunch arrangement—moments and thrusts.

(iii) Haunch restraints and stability

The spacing of restraints to the compression flange of the haunch are designed to comply with Clause 5.5.3.5.2 of BS 5950. The properties of the haunch sections at AA and BB (Figure 4.8), calculated using the formula from Appendix B.2.5 of BS 5950, are listed in Table 4.1. The UB properties and moments and thrusts are also shown.

Check haunch between sections AA and BB:

$$\text{Effective length, } L_E = 1500 \text{ mm} \quad \lambda = 1500/36.5 = 41.1 \quad p_c = 236.4 \text{ N/mm}^2 \text{ (Table 27(c))} \quad \lambda/x = 41.1/64.9 = 0.63$$

Table 4.1 Properties of rafter haunch sections

Section	A (cm <sup>2</sup> )	I <sub>X</sub> (cm <sup>4</sup> )	I <sub>Y</sub> (cm <sup>4</sup> )	Z <sub>X</sub> (cm <sup>3</sup> )	S <sub>X</sub> (cm <sup>3</sup> )	Y <sub>Y</sub> (cm)	u	x	M (kN/m)	F (kN)
AA	150.3	213446	2007	4193	5128	3.65	0.822	89.1	763.8	211.5
BB	125.5	109723	2005	—	3374	3.99	0.842	64.9	507.4	207.1
CC	104	47500	2010	1800	2060	4.38	0.865	41.6	303.5	203.1

Slenderness factor  $V=0.99$  (Table 14) Equivalent uniform moment factor  $m=1$   $\lambda_{LT} = 0.822 \times 0.99 \times 41.1 = 33.4$   $p_b = 273 \text{ N/mm}^2$

$$\text{For section AA : } \frac{211.5 \times 10}{236.4 \times 150.3} + \frac{763.8 \times 10^3}{275 \times 5128} = 0.61$$

For section BB the combined criterion is 0.62. Thus the section is satisfactory.

A similar check is carried out on the haunch section between sections BB and CC. This gives a maximum combined criterion of 0.62.

The rafter and haunch meet conditions specified in BS 5950. The limiting spacing  $L_s$  for the compression flange restraints is given for Grade 43 steel by the following equation:

$$\text{Haunch depth/rafter depth} = 1054.2/528.3 = 2.0$$

$$K_1 = 495$$

$$L_s = \frac{495 \times 36.5 \times 89.1}{[(72 \times 89.1^2) - 10^4]^{1/2}} = 2148 \text{ mm}$$

Put restraints to the compression flange at sections BB and CC, the end of the haunch.

Check rafter between end of haunch CC and point of contraflexure DD:



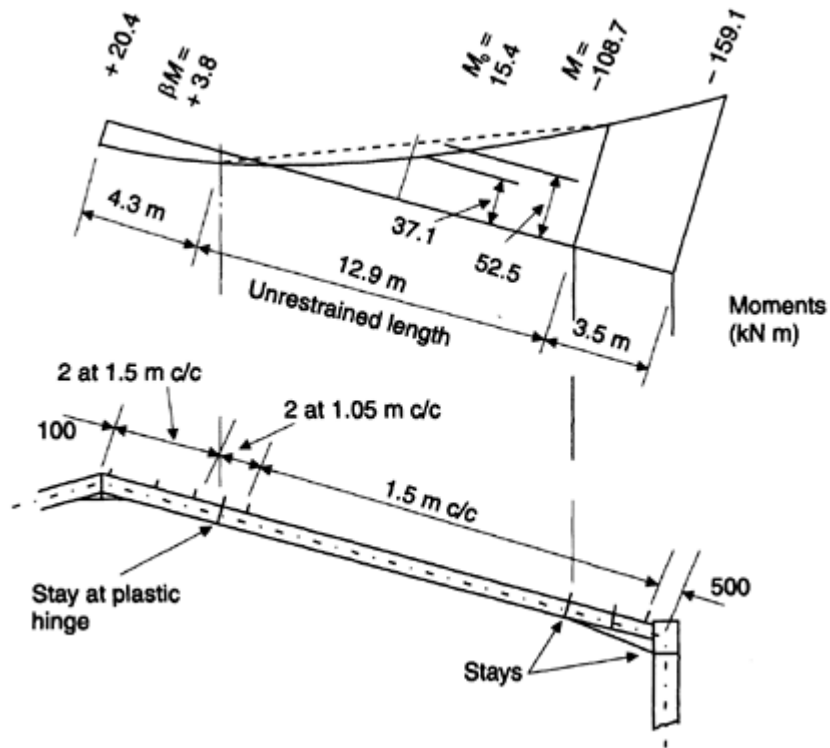

Fig. 4.9 Wind uplift moments—rafter stays: dead and transverse wind loads.

$$\lambda = \frac{2640}{43.8} = 60. \quad p_c = 240.4 \text{ N/mm}^2 \quad \lambda/x = 60.3/41.6 = 1. \quad V = 0.97 \text{ (Table 14)} \quad \lambda_{LT} = 0.865 \times 0.97 \times 60.3 = 50.6 \quad p_b = 236.5 \text{ N/mm}^2 \quad n = 1.0 \text{ (rafter loaded)}$$

Combined criterion:

$$\frac{203.1 \times 10}{104 \times 240.4} + \frac{303.5 \times 10^3}{236.5 \times 2060} = 0.7$$

#### (iv) Rafter near ridge—plastic analysis

Under dead and imposed load, a hinge forms near the ridge as shown in Figure 4.5(a). Purlins are spaced at not greater than  $L_m$  adjacent to the hinge. These restrain the compression flange (Clause 5.3.5 of code). At the hinge,

$$f_c = 146 \times 10/104 = 14 \text{ N/mm}^2$$

$$L_m = \frac{38 \times 43.8}{[(14/130) + (41.6/36)]^{1/2}} = 1385 \text{ mm}$$

Put purlins at 1050 mm near the hinge.

Stays to the bottom flange are not required at this hinge, which is the last to form. However, under load reversal due to wind, a stay is required and will be located at the hinge position. The purlin arrangement is shown in Figure 4.9.

### 4.2.8

#### Rafter under wind uplift

The bending moment diagram for the case of dead and transverse wind load is shown in Figure 4.9 for the leeward portal rafter. The bottom flange is in compression over the unrestrained length between stays at the eaves and the plastic moment near the ridge of 12.9 m.

The stability is checked in accordance with Section 4.3 of BS 5950. The member is loaded between the lateral restraints, so the slenderness correction factor  $n$  is determined.

The rafter uses 533×210 UB 82, with  $r_y = 4.38 \text{ m}$ ,  $u = 0.865$ ,  $x = 41.6$ ,  $S_x = 2060 \text{ cm}^3$ ,  $A = 104 \text{ cm}^2$ .

$$\lambda = 12900/43.8 = 295 \quad \lambda/x = 295/41.6 = 7.09 \quad v = 0.728 \text{ (Table 14)}$$

From the moment diagram,  $\beta = -3.8/108.7 = -0.03$ ,  $M = -108.7 \text{ kNm}$ ,  $M_0 = 15.4 \text{ kNm}$  and  $\gamma = -M/M_0 = -7.1$  (Tables 16 and 17),  $n = 0.654$ .

$\lambda_{LT}=0.654 \times 0.865 \times 0.728 \times 295=121.5$   $p_b=94.2 \text{ N/mm}^2$   $M_b=194.1 \text{ kNm}$   
 (Figures 4.6(a) and 4.9). The thrust in the rafter at the location of moment  $M=108.7 \text{ kNm}=39.5 \text{ kN}$  (compression).  
 $\lambda=295$   $p_c=21.5 \text{ N/mm}^2$  (Table 27(b))  $P_c=21.5 \times 104/10=223.6 \text{ kN}$

Combined:

$$(39.5/223.6)+(108.7+194.1)=0.74$$

This is satisfactory.

The elastic stability could also have been checked taking account of restraint to the tension flange (BS 5950, Appendix G) (Figure 4.6(b)). The case of maximum uplift can be checked in a similar manner. The rafter again is satisfactory.

#### 4.2.9 Portal joints

(a)

*Eaves joint bolts—dead and imposed load*

The joint arrangement is shown in Figure 4.10(a). Assume the top four rows of bolts resist moment. Joint actions are

$$M=814 \text{ kNm} \quad F=212.8 \text{ kN} \quad V=162.8 \text{ kN}$$

With bolts at lever arms 684 mm, 784 mm, 884 mm, and 984 mm, the bolt group modulus is given by

$$\frac{\sum y^2}{y_{\max}} = \frac{2(684^2 + 784^2 + 884^2 + 984^2)}{984} = 5757 \text{ mm}$$

and the maximum bolt tension is

$$T = \frac{814 - (162.8 \times 0.78)}{5.757} = 119.3 \text{ kN}$$

Use 22 mm dia. Grade 8.8 bolts with capacity of 136 kN.

$$\text{Shear per bolt} = 212.8/14 = 15.2 \text{ kN}$$

$$\text{Shear capacity} = 114 \text{ kN}$$

Combined shear and tension (Clause 6.3.6.3):

$$\frac{15.2}{114} + \frac{119.4}{136} = 1.01 < 1.4$$

which is satisfactory.

The joint must also be checked for the reverse wind moment of 392.5 kN.

(b)

*Column UB flange*

The yield line pattern is shown in Figure 4.10(b). For the top bolt the work equation is

$$(127+103)M\theta + (95.8+30+41.8)0.88M\theta = 119.4 \times 42\theta \times 10^3 \quad M = 13.3 \times 10^3 \text{ Nmm per mm} < M_R = 275 \times 14.8^2/4 = 15.1 \times 10^3 \text{ Nmm per mm}$$

The flange is satisfactory.

A further stiffener is required between the second and third bolts.

(c)

*Rafter endplate*

For the weld, try 8 mm fillet—strength 1.2 kNmm; 100 mm of weld resists 120 kN. The yield line pattern is shown in Figure 4.10(c).

The second bolt is critical in determining endplate thickness  $t$ . The work equation is

$$(100+76)M\theta = 107.2 \times 47.2\theta \times 10^3 \quad M = 28.7 \times 10^3 \text{ Nmm per mm} \quad = 265 \times t^2/4 \quad t = 20.8 \text{ mm}$$

Provide 22 mm plate,  $p_y=265 \text{ N/mm}^2$ .

(d)

*Check column web shear*

$$\text{Shear} = (404.7 \times 2) + 162.8 = 967.5 \text{ kN}$$

$$\text{Shear capacity} = 0.6 \times 275 \times 602.2 \times 10.6/10^3 = 1053.2 \text{ kN}$$

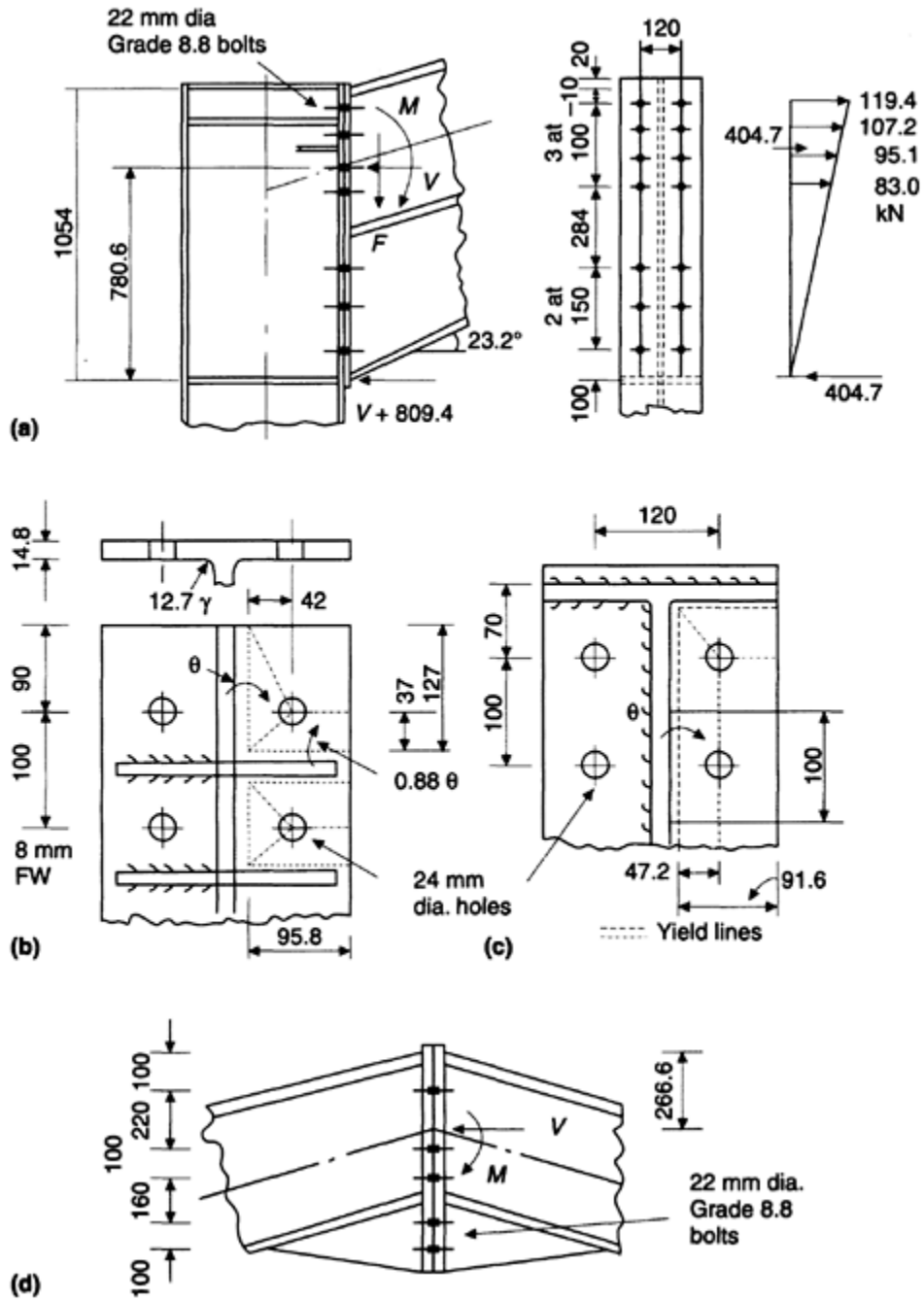

Fig. 4.10 Portal joints: (a) joint arrangement and bolt loads; (b) UB flange; (c) endplate; (d) ridge joint.

The web is satisfactory.

(e)  
Column stiffeners

Top and bottom stiffener loads=967.5 kN

Try two 20×100 stiffeners:

Capacity=20×100×2×265/100=1060 kN

Use weld with 8 mm fillet.

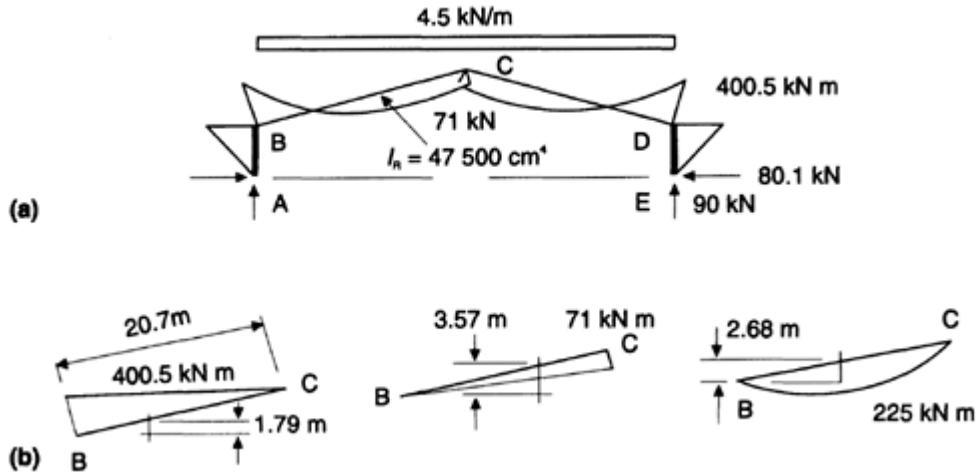

Fig. 4.11 Portal bending moments: (a) overall; (b) separate elements of rafter moments.

(f)  
Haunch flange (Figure 4.10(a))

Load =  $967.5 \sec 23.2^\circ = 1052.6 \text{ kN}$   
 Flange thickness required to carry load  
 $= (1052.6 \times 10^3) / (265 \times 208.7) = 19 \text{ mm}$

The haunch could be cut from 533×210 UB 122, where flange thickness is 21.3 mm. Alternatively, a small length of web of the 533×210 UB 82 can be counted in to carry part of the load. This reduces the bolt lever arm slightly.

(g)  
Base plate and HD bolts

Provide 20 mm base plate and 4 No. 22 mm dia. HD bolts.

(h)  
Ridge joint (Figure 4.10(d))

Joint actions are  
 $M = 414.4 \text{ kNm}$   
 $V = 162.8 \text{ kN}$   
 $\sum y^2 = 2(680^2 + 580^2 + 420^2) = 1.95 \times 10^6 \text{ mm}^2$   
 Maximum bolt tension is given by

$$T = \left( \frac{414.4 - (162.8 \times 0.27)}{1.95 \times 10^3} \right) \times 680 = 129.2 \text{ kN}$$

Provide 22 mm dia. Grade 8.8 bolts.

#### 4.2.10 Serviceability check

The outward deflection of the columns at the eaves is calculated using a classical method set out in British Constructional Steelwork Association Publication 19, 1963.

The portal bending moment diagram due to the unfactored imposed load is shown in Figure 4.11. The separate elements forming the rafter moments are shown. The uniform load causes a moment  $WL^2/8 = 225 \text{ kNm}$ .

The outward deflection at the eaves is given by

$$\delta_B = \frac{\sum \text{Areas of bending moment diagram on BC} \times (\text{Lever arm to level BD})}{EI_R} = \frac{-(400.5 \times 20.7 \times 7 \times 1.79/2) + (71 \times 20.7 \times 3.57/2) + (2 \times 225 \times 20.7 \times 2.68/3) \times 10^5}{(205 \times 47500)} = 36.2 \text{ mm} (> h/300 = 16.7 \text{ mm})$$

The metal sheeting can accommodate this deflection.

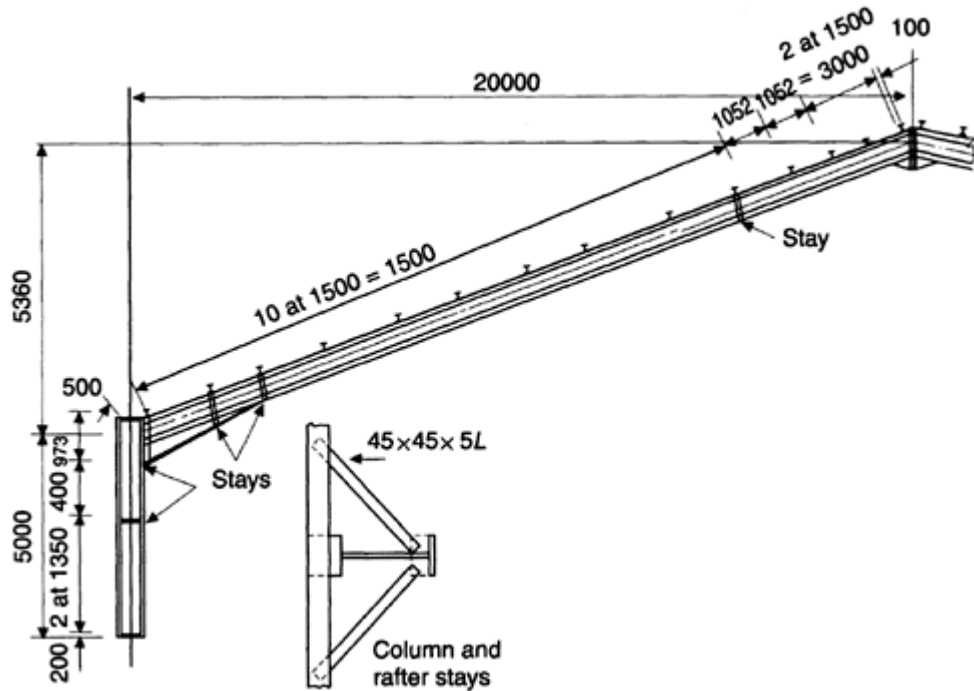

Fig. 4.12 Plastic-designed portal.

A drawing of the portal is shown in Figure 4.12.

### 4.3

#### BUILT-UP TAPERED MEMBER PORTAL

##### 4.3.1

##### General comments

The design process for the tapered welded I-section member portals commonly used in the USA is reviewed briefly (Figure 4.13).

The design is made using elastic theory. The portal members are made deeper at the eaves. The columns taper to the base and the rafters may be single or double tapered as shown in the figure. This construction is theoretically the most efficient with the deepest sections at points of maximum moments.

##### 4.3.2

##### Design process

The complete design method is given in Lee *et al.* (1981). The analysis may be carried out by dividing the frame into sections, over which the mid-point properties are assumed to be constant, and using a frame program.

A series of charts are given to determine the in-plane effective lengths of the portal members. The tapered members are converted into equivalent prismatic members. Charts are given for single- and double-tapered members. Another series of charts give the effective length factors for sway-prevented and permitted cases. The in-plane effective lengths depend on the spacing of the restraint. The design can then proceed to the required code. The textbook by Lee *et al.* should be consulted for the complete treatment.

### 4.4

#### TWO-PINNED ARCH

##### 4.4.1

##### General considerations

The arched roof is most commonly constructed in the form of a circular arc. It has been used extensively for sports arenas, bus and rail terminals, warehouses etc. Many variations in arched roof construction are possible including circular and parabolic shapes, three-pinned, two-pinned and fixed types, multiarched roofs and barrel vaults in three-way grids.

A design is made for a rib in an arched roof building to the same general specification as that for the portals considered earlier in the chapter. This enables a comparison to be made with these structures. This is redesigned as a lattice arch.

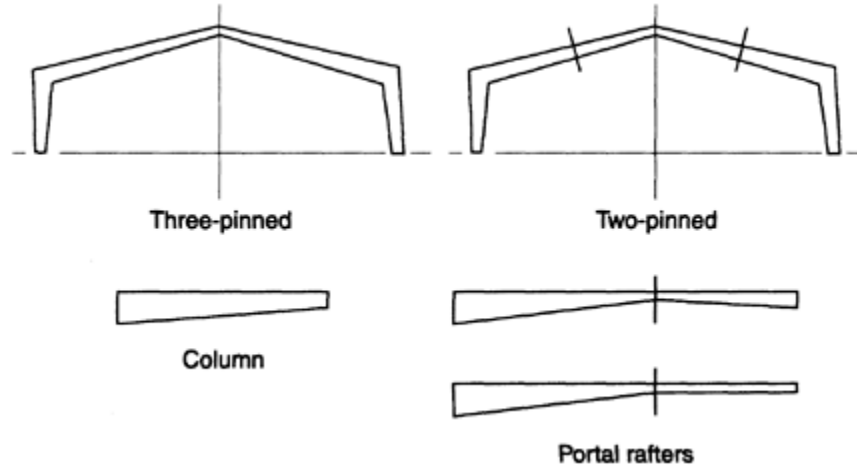

Fig. 4.13 Tapered member portals.

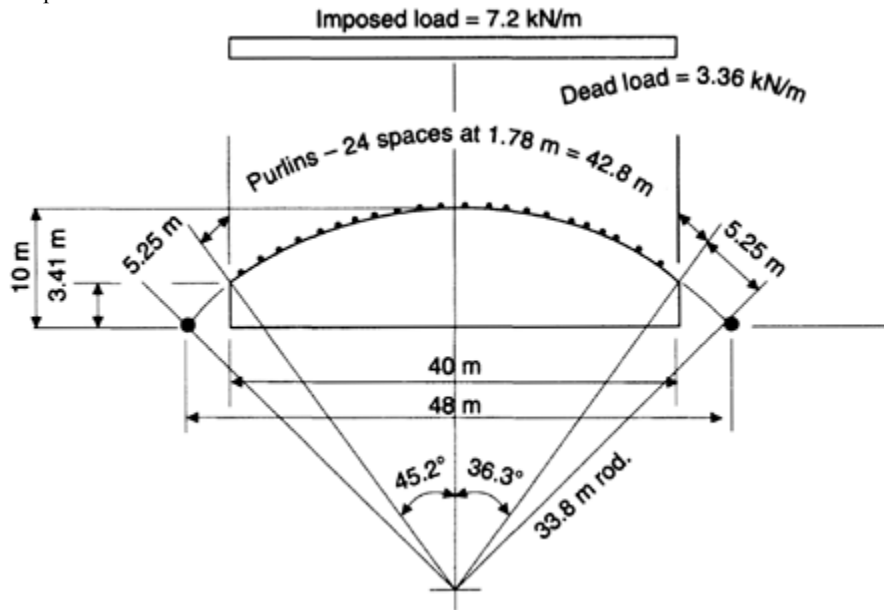

Fig. 4.14 Section through building.

The arch rib is sized for dead and imposed load. The maximum conditions occur when the imposed load covers about two-thirds of the span. The wind load causes uplift and tension in the arch.

Arch stability is the critical feature in design. The two-hinged arch buckles in-plane into an anti-symmetrical shape with a point of contraflexure at the crown. The expression for effective length is

$$l = (1.02 \text{ to } 1.25) \times (\text{Arch length}/2)$$

The higher factors apply to high-rise arches (Johnson, 1976; Timoshenko and Gere, 1961). Lateral supports are also required.

#### 4.4.2 Specification

The two-pinned arch has span 48 m, rise 10 m, spacing 6 m. Dead load is 0.4 kN/m<sup>2</sup> and imposed load 0.75 kN/m<sup>2</sup> on plan. A section through the building is shown in Figure 4.14. It has a clear span of 40 m between side walls and the steel ribs extend outside. The arch rib is to be a rectangular hollow section in Grade 43 steel.

### 4.4.3 Loading

#### (a) Dead load

$$\text{Roof design load} = 1.4 \times 0.4 \times 6 = 3.36 \text{ kN/m}$$

$$\text{Arch rib1 kN/m} = 1.4 \times 5.25 = 7.4 \text{ kN}$$

The loads are applied at 13 points on the roof, as shown in [Figure 4.15\(a\)](#).

The joint coordinates are shown in [Figure 4.15\(b\)](#).

#### (b) Imposed load

$$\text{Roof design load} = 1.6 \times 0.75 \times 6 = 7.2 \text{ kN/m on plan}$$

The loads for two cases are shown in [Figure 4.15\(c\)](#) and (d):

- imposed load over the whole span;
- imposed load over 63% of span.

The second case is found to give maximum moments

#### (c) Wind load

Basic wind speed is 45 m/s, ground roughness 3, building size C, height 10 m.

$$\text{Design wind speed} = 0.69 \times 45 = 31.1 \text{ m/s}$$

$$\text{Dynamic pressure} = 0.613 \times 31.1^2 / 10^3 = 0.59 \text{ kN/m}^2$$

External pressure coefficients  $C_{pe}$ , taken from Newberry and Eaton (1974) for a rectangular building with arched roof, are shown in [Figure 4.16](#). For  $\alpha = 90^\circ$ ;  $C_{pe} = -0.8$  in division A, causing maximum uplift.

Wind load puts the arch in tension if the internal suction  $C_{pi}$  is taken as  $-0.3$  for the case where the four walls and roof are equally permeable.

### 4.4.4 Analysis

Analyses are carried out for:

1. dead load;
2. imposed load over whole roof;
3. imposed load on 63% of roof.

The joint coordinates are shown in [Figure 4.15\(b\)](#).

Successive trials are needed to establish that case 3 gives the maximum moment in the arch rib. The wind load causes tension in the arch, and the analysis is not carried out for this case.

The bending moment diagrams for the three load cases are shown in [Figure 4.17](#). The arch thrusts at critical points are noted in the diagrams.

### 4.4.5 Design

#### (a) Maximum design conditions

For dead and imposed loads over whole span, at joint 14

$$F = 117.8 + 234.5 = 352.3 \text{ kN}$$

$$M = 32.7 + 98.6 = 131.3 \text{ kNm}$$

For dead and imposed loads over 63% of span, at joint 13

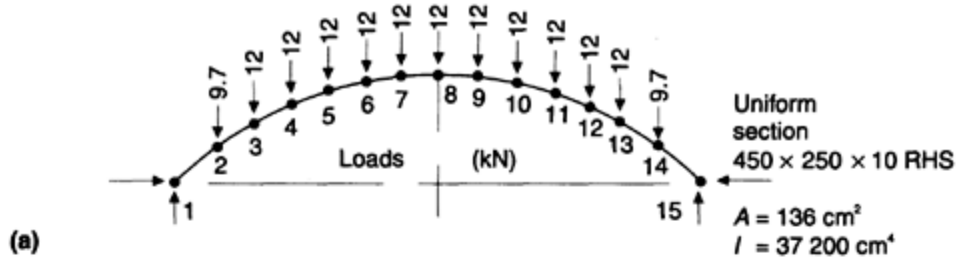

No.	x	y	No.	x	y	No.	x	y
1	0.0	0.0	6	16.91	9.25	11	34.53	8.32
2	4.0	3.44	7	20.44	9.51	12	37.86	7.03
3	6.97	5.39	8	24.0	10.0	13	41.03	5.39
4	10.14	7.03	9	27.56	9.81	14	44.0	3.44
5	13.47	8.32	10	31.09	9.25	15	48.0	0.0

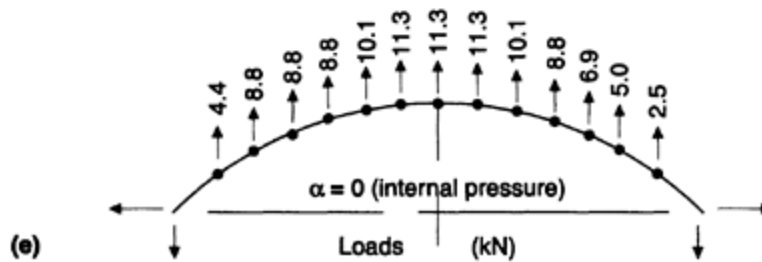
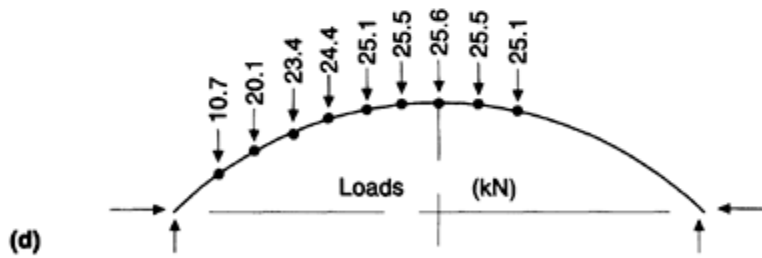
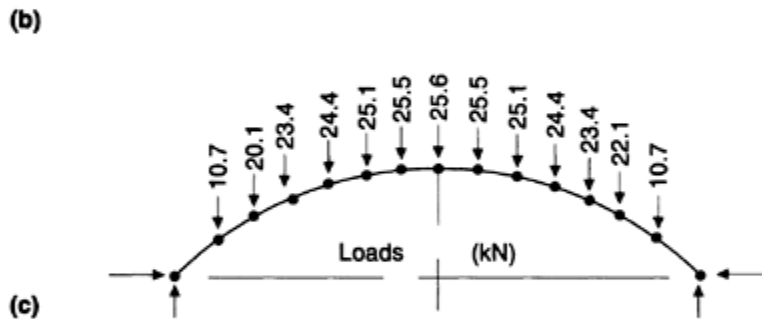

Fig. 4.15 Arched roof loading: (a) design dead loads—joints; (b) joint coordinates (m); (c) design imposed load—whole span; (d) design imposed load—63% of span; (e) characteristic wind load.

$$F=1111.4+169.9=281.3 \text{ kN}$$

$$M=26.9+265.4=292.3 \text{ kNm}$$

(b)  
Trial section

This is to be 450×250×10 RHS×106 kg/m, for which  $A=136 \text{ cm}^2$ ,  $S_x=2010 \text{ cm}^3$ ,  $r_x=16.6 \text{ cm}$ ,  $r_y=10.5 \text{ cm}$ .



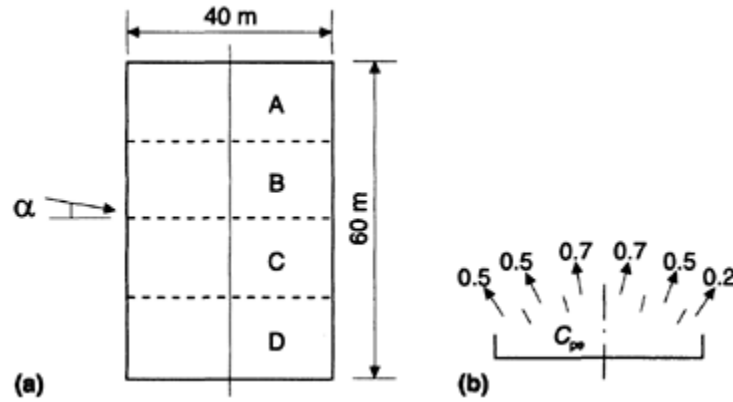

Fig. 4.16 External pressure coefficients for wind angle  $\alpha=0$ .

(c)  
Arch stability

The in-plane buckled shape of the arch is shown in Figure 4.18(b). The arch is checked as a pin-ended column of length  $S$  equal to one-half the length of the arch. The effective length factor is 1.1.

$$l/r_x = 1.1 \times 26700/166 = 177 < 180 \quad p_c = 58.8 \text{ N/mm}^2 \text{ (Table 27(a))}$$

Lateral stability is provided by supports at the quarter points as shown in Figure 4.18(a).

$$l/r_y = 13350/105 = 127.1$$

Lateral torsional buckling (Appendix B.2.6 of code):

$$\lambda = 127.1, D/B = 1.8 \quad \text{Limiting } \lambda \text{ for } D/B = 1.8 \text{ for } p_y = 275 \text{ N/mm}^2 > 350 \quad p_b = 275 \text{ N/mm}^2 \quad M_b = 275 \times 2010/10^3 = 552.8 \text{ kNm}$$

(d)  
Capacity check

For joint 14:

$$\frac{352.3 \times 10}{58.8 \times 136} + \frac{131.3}{552.8} = 0.68$$

For joint 13:

$$\frac{281.3 \times 10}{58.8 \times 136} + \frac{292.3}{552.8} = 0.88$$

The arch rib selected is satisfactory.

Note that if the imposed load is extended to joint 11, i.e. 70% of span,  $F=299.5 \text{ kN}$ ,  $M=280.6 \text{ kNm}$  and capacity check gives 0.88.

#### 4.4.6 Construction

The arch is fabricated in three sections 18.8 m long. The rib is bent to radius after heating. The sections are joined by full strength welds on site with the arch lying flat. It is then lifted into its upright position. The arch site welds and springing detail as shown in Figure 4.19.

#### 4.4.7 Lattice arch

(a)  
Specification

An alternative design is made for a lattice arch with structural hollow section chords 1 m apart and mean radius 33.8 m, the same as the single section rib designed above.

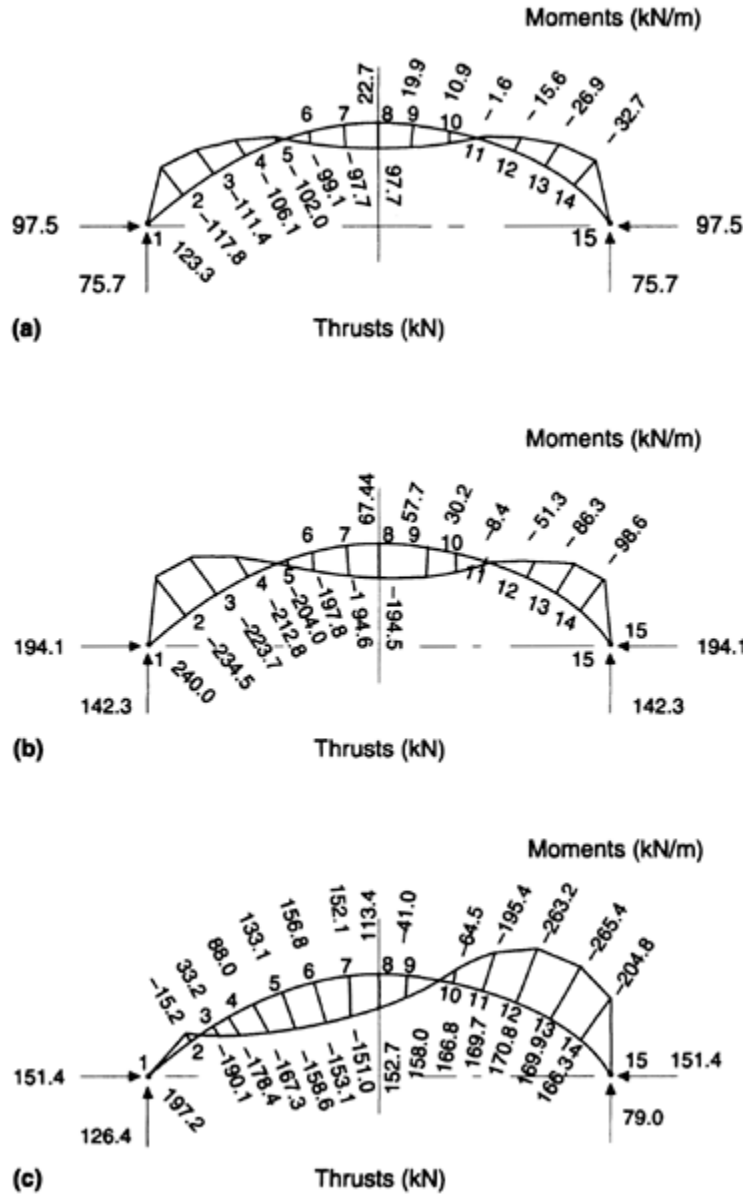

Fig. 4.17 Bending moments: (a) dead loads; (b) imposed load—whole span; (c) imposed load—63% of span.

The arrangement of the arch, the lateral restraints and a section through the rib are shown in Figure 4.20. The coordinates of the joints and the loads applied at the purlin points are listed in Table 4.2. The critical load case consisting of dead load plus imposed load covering 63% of the span is shown.

A preliminary design is made using results from the single rib design above. This is compared with the design made for an accurate analysis of the lattice arch.

(b)  
*Preliminary design*

(i) Trial section (Figure 4.20)

The chords are 150×100×6.3 RHS, with  $A=29.7 \text{ cm}^2$ ,  $I_Y=479 \text{ cm}^3$ ,  $r_X=5.53 \text{ cm}$ ,  $r_Y=4.02 \text{ cm}$ ,  $S_X=111 \text{ cm}^3$ .  
The web is 60×60×3.2 SHS, with  $A=7.22 \text{ cm}^2$ ,  $r=2.31 \text{ cm}$ ,  $S=15.3 \text{ cm}$ .

(ii) Maximum design conditions

For joint 13, dead and imposed load on 63% of span:

$F=281.3 \text{ kN}$                        $M=292.3 \text{ kNm}$  (tension in top chord)                      Purlin load=6 kN (dead load on top chord)

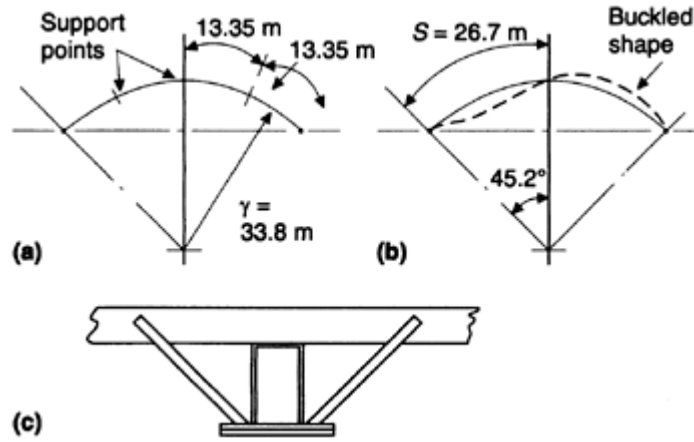

Fig. 4.18 Arch stability: (a) lateral support; (b) in-plane buckling; (c) support.

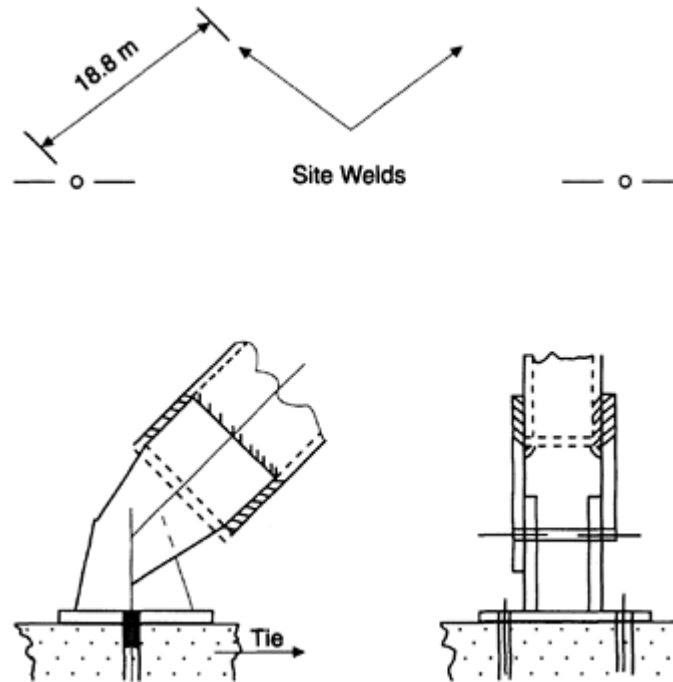

Fig. 4.19 Construction details.

For joint 7, dead and imposed load on 63% of span:

Table 4.2 Lattice arch-coordinates and loads

No.	x (m)	y (m)	Load (kN)	No.	x (m)	y (m)	Load (kN)	No.	x (m)	y (m)	Load (kN)
1	0	0	1.3	17	17.01	8.76	—	33	34.68	8.79	6.0
2	0.93	1.59	2.5	18	16.80	9.74	18.7	34	36.39	8.18	6.0
3	1.61	0.85	—	19	18.58	10.07	18.8	35	37.65	6.57	—
4	2.28	2.75	2.5	20	20.47	9.31	—	36	38.06	7.49	6.0
5	4.29	3.04	—	21	20.37	10.31	18.9	37	39.69	6.70	6.0
6	3.69	3.85	9.7	22	22.17	10.45	19.0	38	40.77	4.97	—
7	5.19	4.88	16.9	23	24.0	9.5	—	39	41.27	5.83	6.0
8	7.23	4.97	—	24	24.0	10.5	19.1	40	42.81	4.88	6.0
9	6.73	5.83	17.2	25	25.83	10.45	19.0	41	43.71	3.04	—
10	8.31	6.70	17.6	26	27.53	9.31	—	42	44.31	3.85	4.3
11	10.35	6.57	—	27	27.63	10.31	18.9	43	45.72	2.75	2.5
12	9.94	7.49	17.9	28	29.42	10.07	12.4	44	46.39	0.85	—

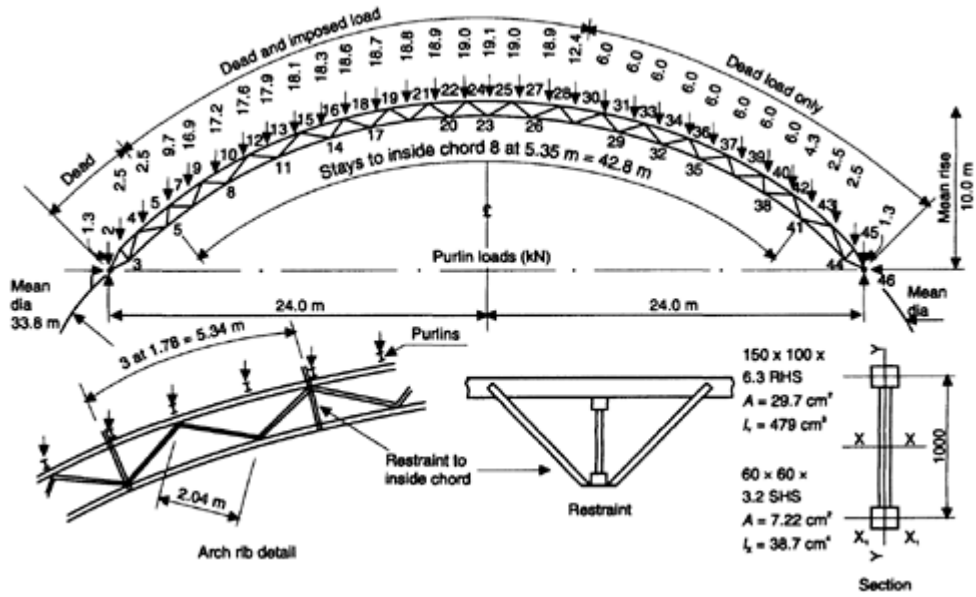

Fig. 4.20 Lattice arch.

No.	x (m)	y (m)	Load (kN)	No.	x (m)	y (m)	Load (kN)	No.	x (m)	y (m)	Load (kN)
13	11.61	8.18	18.1	29	30.99	8.76	–	45	47.07	1.59	2.5
14	13.62	7.84	–	30	31.20	9.74	6.0	46	48.0	0	1.3
15	13.31	8.79	18.3	31	32.96	9.31	6.0				
16	15.04	9.31	18.6	32	34.38	7.84	–				

$F=248.7 \text{ kN}$

$M=172.0 \text{ kNm}$  (compression in top chord)

Purlin load=18.7 kN (dead and imposed load on top chord)

(iii) Member capacities

Compression

For the whole arch buckling in plane:

$$r_x = \{[(29.7 \times 2 \times 500^2) + (2 \times 479)] / (2 \times 29.7)\}^{1/2} = 500 \text{ cm} \quad l/r_x = 1.1 \times 26700 / 500 = 58.7$$

The slenderness ratios are based on the mean diameter of the arch. For arch chord in plane of arch,  $l/r_{x1} = 0.85 \times 3560 / 40.2 = 75$ .

3. For arch chord out of plane (lateral restraints are provided at 5.34 m centres).

$$l/r_y = 5340 / 55.3 = 96.6 \quad p_c = 164.8 \text{ N/mm}^2 \text{ (Table 27(a))} \quad P_c = 164.8 \times 29.7 / 10 = 489.5 \text{ kN}$$

Bending

$$M_c = 275 \times 111 / 10^3 = 30.5 \text{ kNm}$$

(iv) Design check

For joint B, check compression in bottom chord:

$$\text{Load} = (281.3/2) + 292.3 = 432.9 \text{ kN} \quad \text{Capacity} = 489.5 \text{ kN}$$

For joint 7, check compression and bending in the top chord. Secondary bending due to the purlin load is

$$M = WL/12 = 18.7 \times 3.56 / 12 = 5.55 \text{ kNm}$$

and

$$\text{Compression force} = (248.7/2) + 170.2 = 296.4 \text{ kN}$$

Capacity check:

$$\frac{296.4}{489.5} + \frac{5.55}{30.5} = 0.79$$

The section selected is satisfactory.

(v) Web members

The maximum shear in the arch at the support is 45.0 kN, so that

Web member force =  $45 \times 2.04 = 91.8$  kN

Select from capacity, tables in Steel Construction Institute (1987):  $60 \times 60 \times 3.2$  SHS with capacity 136 kN for an effective length of 2 m. Make all the internal members the same section.

(c)

*Accurate design*

A computer analysis is carried out using the arch dimensions, coordinates, section properties and loads shown in Figure 4.20 and Table 4.2.

The maximum design conditions from the analysis are given below:

- top chord—

Member 16–18,  $F = -326.9$  kN,  $M = 1.06$  kNm

Member 36–37,  $F = 167.8$  kN,  $M = -8.71$  kNm

- bottom chord—

Member 35–38,  $F = -400.0$  kN,  $M = -1.84$  kNm

- web members—

Member 28–29,  $F = -99.9$  kN,  $M = -0.23$  kNm

**(i) Check chord members** ( $150 \times 100 \times 6.3$  RHS)

Capacities (Section 4.4.7 (b)) are

Tension  $P_t = 29.7 \times 275 / 10 = 816.8$  kN

Compression  $P_c = 489.5$  kN

Bending  $M_c = 30.5$  kNm

For member 16–18:

$$(326.9/489.5) + (1.06/30.5) = 0.7$$

For member 36–37:

$$(167.8/816.8) + (8.71/30.5) = 0.5$$

For member 35–38:

$$(400/489.5) + (1.84/30.5) = 0.88$$

The section chosen is satisfactory.

**(ii) Check web member** ( $60 \times 60 \times 3.2$  SHS)

This member could be reduced to  $60 \times 60 \times 3$  SHS with capacity in compression of 129 kN for 2.0 m effective length. Make all web members the same section  $60 \times 60 \times 3$  SHS  $\times 5.34$  kg/m.

# CHAPTER 5

## Multistorey buildings

### 5.1 OUTLINE OF DESIGNS COVERED

#### 5.1.1 Aims of study

Various methods are set out in BS 5950 for design of building structures. These methods were listed and discussed in general terms in [Chapter 2](#).

To show the application of some of the methods a representative example of a four storey building is designed using different code procedures and compared.

#### 5.1.2 Design to BS 5950

Designs are made to the following methods specified in BS 5950 for a braced frame:

1. simple design
2. rigid elastic design
3. rigid plastic design
4. semirigid plastic design.

### 5.2 BUILDING AND LOADS

#### 5.2.1 Specification

The framing plans for the multistorey office building selected for the design study are shown in [Figure 5.1](#). The office space in the centre bays is of open plan with any offices formed with light partitions. The end bays contain lifts, stairs and toilets. [Figure 5.2](#) shows relevant detail at walls and columns for estimation of loads.

The building specification is:

- steel frame with cast-*in-situ* floors;
- dimensions—30 m×16 m×18 m high with frames at 5 m centres;
- external cladding—brick/breeze block and double glazing;
- the building is fully braced in both directions.

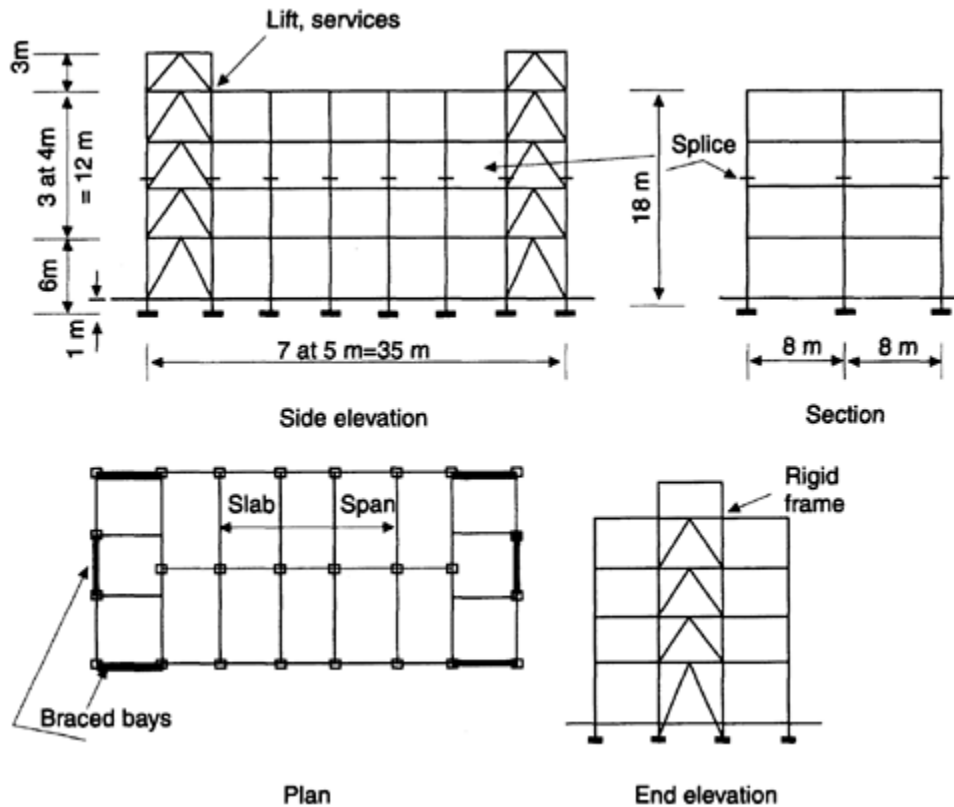

Fig. 5.1 Fully braced building—framing plans.

## 5.2.2 Loads

### (a) Dead loads

#### (i) Roof

Topping ( $1.0 \text{ kN/m}^2$ ) + Slab ( $4.1 \text{ kN/m}^2$ ) + Steel ( $0.2 \text{ kN/m}^2$ ) + Ceiling ( $0.5 \text{ kN/m}^2$ ) + Services ( $0.2 \text{ kN/m}^2$ ) =  $6 \text{ kN/m}^2$

#### (ii) Floor

Tiles, screed ( $0.7 \text{ kN/m}^2$ ) + Slab ( $4.3 \text{ kN/m}^2$ ) + Steel ( $0.3 \text{ kN/m}^2$ ) + Partitions ( $1.0 \text{ kN/m}^2$ ) + Ceiling ( $0.5 \text{ kN/m}^2$ ) + Services ( $0.2 \text{ kN/m}^2$ ) =  $7 \text{ kN/m}^2$

#### (iii) Columns and casing

Internal— $1.5 \text{ kN/m}$ , external— $6.3 \text{ kN/m}$  over 2.2 m height.

#### (iv) Wall—parapet (Figure 5.2)

Cavity wall ( $4.8 \text{ kN/m}^2$ ) + Slab ( $4.1 \text{ kN/m}^2$ ) + Steel ( $0.5 \text{ kN/m}$ ) + Ceiling ( $0.5 \text{ kN/m}^2$ ) =  $6.9 \text{ kN/m}$

#### (v) Wall—floor loads (Figure 5.2)

Cavity wall ( $5.1 \text{ kN/m}^2$ ) + Slab ( $4.3 \text{ kN/m}^2$ ) + Steel ( $0.7 \text{ kN/m}$ ) + Double glazing ( $0.6 \text{ kN/m}^2$ ) + Ceiling ( $0.5 \text{ kN/m}^2$ ) =  $10.6 \text{ kN/m}$

### (b) Imposed loads

The imposed loads from BS 6399: Part 1 are:

- roof— $1.5 \text{ kN/m}^2$ ;
- floors (offices with computers)— $3.5 \text{ kN/m}^2$ .

The reduction in imposed loads with number of stories is: 2–10%; 3–20%; 4–30% (Table 2 of the code).

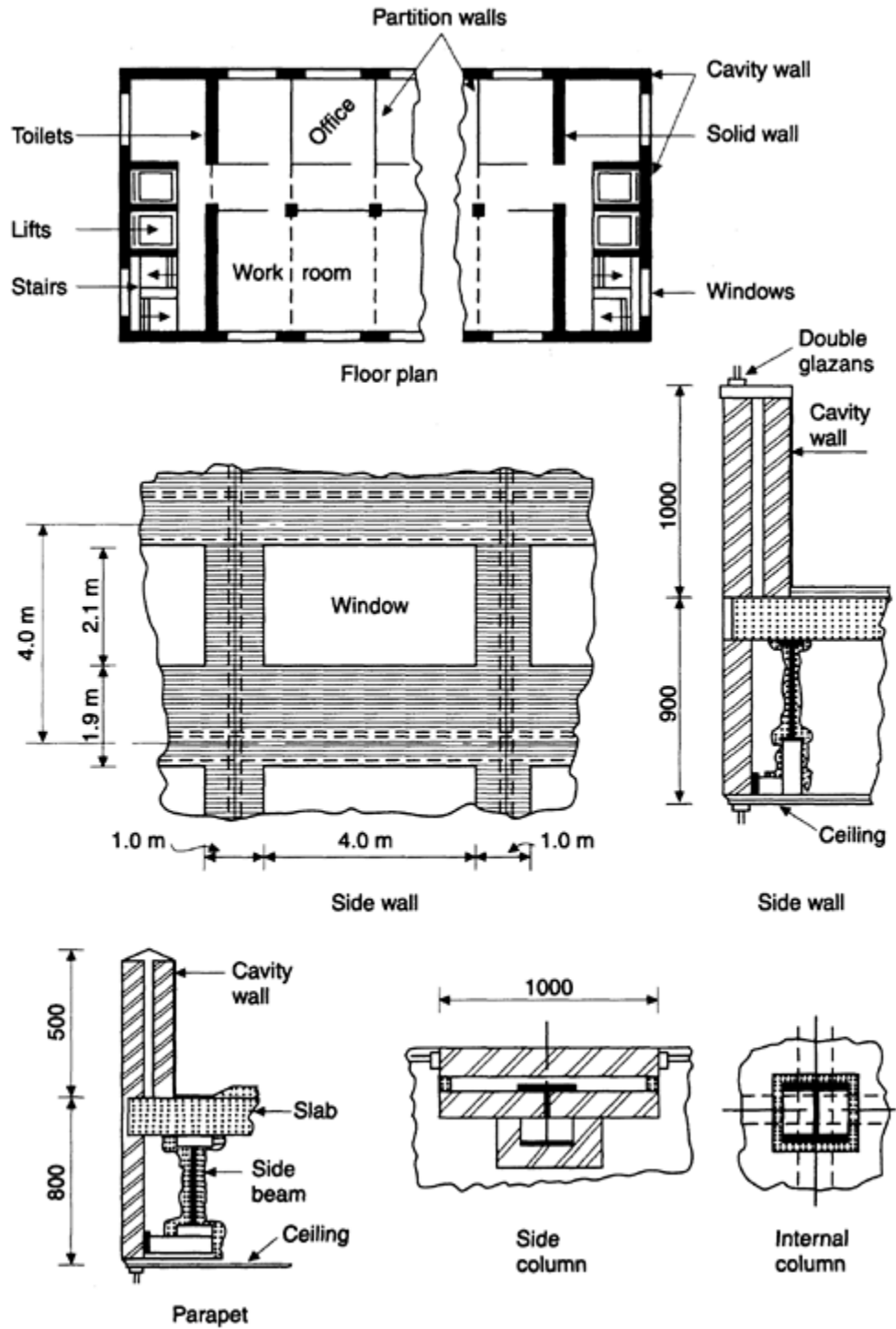

Fig. 5.2 Building details.

### 5.2.3 Materials

Steel used is Grade 43, with bolts Grade 8.8.



### 5.3 SIMPLE DESIGN CENTRE FRAME

#### 5.3.1 Slabs

Slabs can be designed to BS 8110. This conforms as satisfactory that:

- roof slab—170 mm;
- floor slab—180 mm with 10 mm dia. bars at 180 mm centres top and bottom.

#### 5.3.2 Roof beam

Dead load=6 kN/m<sup>2</sup> Imposed load=1.5 kN/m<sup>2</sup> Design load=(1.4×6)+(1.6×1.5)=10.8 kN/m<sup>2</sup>  
 $M=10.8 \times 5 \times 8^2 / 8 = 432 \text{ kNm}$   $S=432 \times 10^3 / 275 = 1571 \text{ cm}^3$   
 Select 457×191 UB 74, with  $S=1660 \text{ cm}^3$ ,  $I_x=33400 \text{ cm}^4$ ,  $T=14.5 \text{ mm}$ ,  $p_y=275 \text{ N/mm}^2$ .  
 Imposed load  $1.5 \times 5 \times 8 = 60 \text{ kN}$

Live load serviceability deflection  $\delta$  is given by

$$\delta = \frac{5 \times 60 \times 10^3 \times 8000^3}{384 \times 205 \times 10^3 \times 33400 \times 10^4} = 5.84 \text{ mm}$$

$$< \text{Span}/360 = 22.2 \text{ mm}$$

Thus section is satisfactory.

#### 5.3.3 Floor beam

Dead load=7.0 kN/m<sup>2</sup> Imposed load=3.5 kN/m<sup>2</sup> Design load=15.4 kN/m<sup>2</sup>  $M=616 \text{ kNm}$   $S=2240 \text{ cm}^3$   
 Select 533×210 UB 92, with  $S=2390 \text{ cm}^3$ .

$$\delta = \text{Span}/973$$

#### 5.3.4 Outer column—upper length 7–10–13 (Figure 5.3)

Check column above second floor level at joint 7:

Imposed load reduction=10% Load 7–10=(6+7)20×1.4+(6.9×5×1.4)+(2×2.2×6.3×1.4) = 669.3 kN  
 Load 7–8=(7×20×1.4)+(3.5×20×1.6)=308 kN

Assume 254×254 UC eccentricity=0.23 m (100 mm from column face). Initially assume moments divided equally.

$$M=308 \times 0.23/2=35.4 \text{ kNm} \quad F=669.3 \text{ kN}$$

Try 203×203 UC 46 with  $r_y=5.11 \text{ cm}$ ,  $S=497 \text{ cm}^3$ ,  $A=58.8 \text{ cm}^2$ ,  $I=4560 \text{ cm}^4$ ,  $T=11.0 \text{ mm}$ ,  $p_y=275 \text{ N/mm}^2$ .

$\lambda=0.85 \times 400/5.11=66.5$   $p_c=188 \text{ N/mm}^2$  (Table 27  $\lambda_{LT}=0.5 \times 400/5.11=39.1$ ,  $p_b=264 \text{ N/mm}^2$  (Table 11)  $M_{bs}=264 \times 497/10^3=131.2 \text{ kNm}$

Combined:

$$\frac{669.3 \times 10}{188 \times 58.8} + \frac{35.4}{131.2} = 0.88$$

The section is satisfactory.

#### 5.3.5 Outer column—lower length 1–4–7(Figure 5.3)

Check column below first floor at joint 4:

Imposed load reduction=20% Load 4–7=1106.7 kN Load 4–5=308 kN

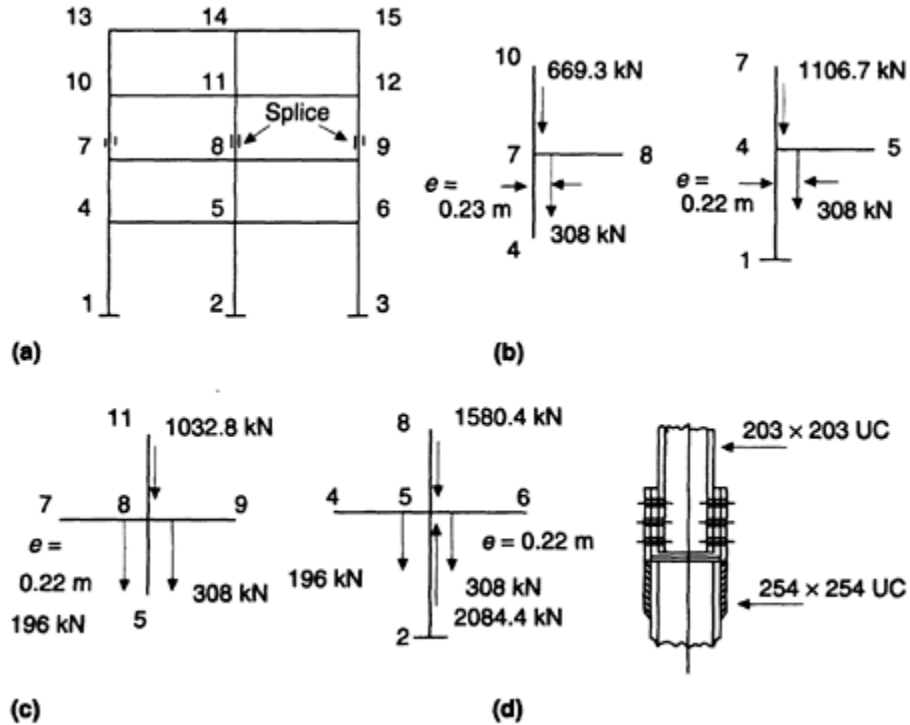

Fig. 5.3 Columns—loads and details: (a) frame; (b) outer column; (c) centre column; (d) splice.

$$(I/I)_{1-4} : (I/I)_{4-7} = (1/6 : 1/4) / \left( \frac{1}{6} + \frac{1}{4} \right) = 0.4 : 0.6$$

$\times 1:1.5$ —divide moments equally  $M=35.4$  kNm  $F=1106.7+308=1414.7$  kN  
 Try 254×254 UC 89, with  $r_y=6.52$  cm,  $S=1230$  cm<sup>3</sup>,  $A=114$  cm<sup>2</sup>,  $I=14300$  cm<sup>4</sup>  $T=17.3$  mm,  $p_y=265$  N/mm<sup>2</sup>.  
 $\lambda=78.2$ ,  $p_c=160.4$  N/mm<sup>2</sup>  $\lambda_{LT}=46$ ,  $p_b=239.8$  N/mm<sup>2</sup>  $M_b=295$  kNm

Combined:

$$\frac{1414.7 \times 10}{160.4 \times 114} + \frac{35.4}{295} = 0.89$$

The division of moments at joint 7 should be rechecked. The section is satisfactory.

### 5.3.6

#### Centre column—upper length 8–11–14 (Figure 5.3 (C))

Refer to BS 5950 Clause 5.1.2.1 which states that the most unfavourable load pattern can be obtained without varying the dead load factor  $\gamma_f$ . Check column above joint 8:

Load 8–11=1032.8 kN Load 7–8=196 kN (imposed load zero) Load 8–9=308 kN

For the column select 203×203 UC 52:

$M=12.3$  kNm  $F=1032.8$  kN

The section is satisfactory.

### 5.3.7

#### Centre column—lower length 2–5–8

Check section below first floor at joint 5 (Figure 5.3(C)).

Load above joint 5=(6 +2×7)4×1.4+(12×1.5+2×3.5)40×1.6×0.8=1580.4 kN Load 5–4=196 kN Load 5–6=308 kN Load below joint 5=2084.4 kN  $M=(308-196)0.23/2=12.9$  kNm

Try 254×254 UC 107, with  $r_y=6.57$  cm,  $S=1490$  cm<sup>3</sup>,  $A=137$  cm<sup>2</sup>,  $T=20.5$  mm,  $p_y=265$  N/mm<sup>2</sup>.

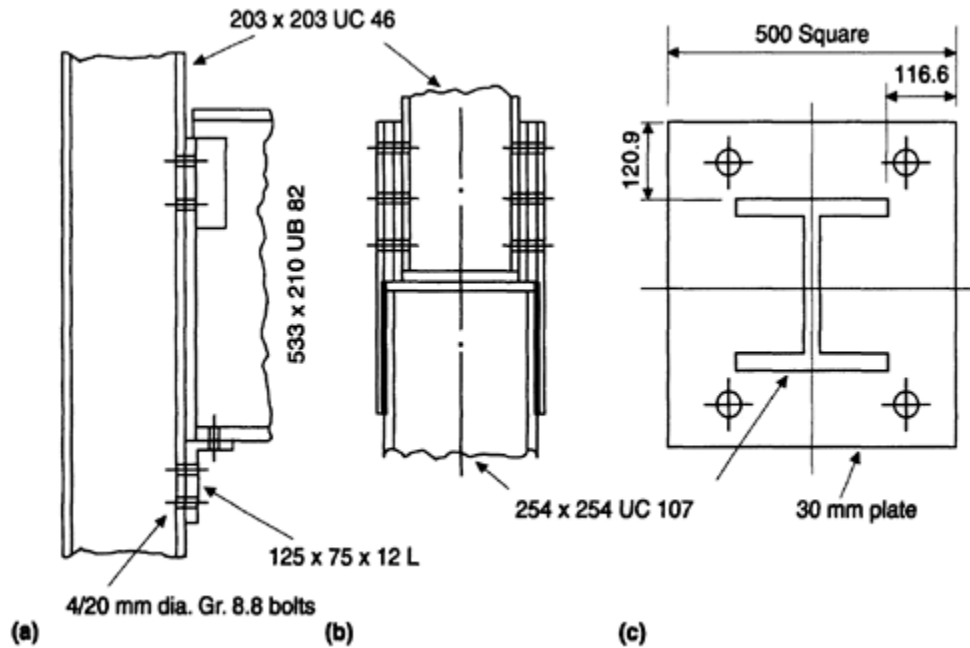

Fig. 5.4 Frame joint details: (a) floor beam connection; (b) column splice; (c) centre column baseplate.

$\lambda = 0.85 \times 600 / 6.57 = 77.6$ ,  $p_c = 161.8 \text{ N/mm}^2$      $\lambda_{LT} = 0.5 \times 600 / 6.57 = 45.7$ ,  $p_b = 240.5 \text{ N/mm}^2$      $M_b = 1490 \times 240.7 / 10^3 = 358.6 \text{ kNm}$   
 Combined:

$$\frac{2084.4 \times 10}{137 \times 161.8} + \frac{12.9}{358.6} = 0.98$$

The section is satisfactory.

### 5.3.8

#### Joint design (Figure 5.4)

Shear = 308 kN

Provide 4 No. 20 mm dia. Grade 8.8 bolts—capacity 110 kN/bolt.

Bearing on 11 mm flange of 203×203 UC 46—101 kN/bolt. The beam/column joint and column splice is shown in the figure.

### 5.3.9

#### Baseplate—centre column (Figure 5.4)

Load = 2088 kN (30% imposed load reduction)

Using concrete grade 30, bearing pressure  $0.4 f_{cu}$ ,

$$\text{Area} = 2088 \times 10^3 / 0.4 \times 30 = 17.4 \times 10^4 \text{ mm}^2$$

Provide 500 mm×500 mm plate, with  $p = 8.35 \text{ N/mm}^2$ . Thickness (BS 5950, Section 4.13.2.2) is given by

$$t = \frac{2.5 \times 8.35}{265} (120.9^2 - 0.3 \times 116.1^2)^{0.5}$$

$$= 29.3 \text{ mm}$$

Provide 30 mm thick baseplate ( $p_y = 265 \text{ N/mm}^2$ ).

## 5.4 BRACED RIGID ELASTIC DESIGN

### 5.4.1 Computer analysis

The building frame, supports, dimensions and design loads are shown in Figure 5.5(a). The areas and moments of inertia of members taken from the simple design are listed in (b) in the figure. Loads on members 5–6, 8–9 and 11–12 are given for two cases:

$$1.4 \times \text{dead} + 1.6 \times \text{imposed} = 77 \text{ kN/m}$$

$$1.4 \times \text{dead} = 49 \text{ kN/m}$$

Analyses are carried out for the following load cases:

1. all spans— $1.4 \times \text{dead} + 1.6 \times \text{imposed}$ ;
2. spans 8–9, 11–12— $1.4 \times \text{dead}$ , other spans— $1.4 \times \text{dead} + 1.6 \times \text{imposed}$ ;
3. spans 5–6, 8–9— $1.4 \times \text{dead}$ , other spans— $1.4 \times \text{dead} + 1.6 \times \text{imposed}$ ;
4. span 5–6— $1.4 \times \text{dead}$ , other spans— $1.4 \times \text{dead} + 1.6 \times \text{imposed}$ ;
5. spans 7–8, 5–6— $1.4 \times \text{dead}$ , other spans— $1.4 \times \text{dead} + 1.6 \times \text{imposed}$ .

The load pattern that should be used to obtain the maximum design conditions is not obvious in all cases. Some comments are as follows.

1. All spans fully loaded should give near the maximum beam moments. Other cases could give higher moments.
2. The external columns are always bent in double curvature. Full loads will give near maximum moments though again asymmetrical loads could give higher values.
3. The patterns to give maximum moments in the centre column must be found by trials. The patterns used where the column is bent in double curvature give the maximum moments.

The results from the computer analysis for case 1 loads are shown in Figure 5.6. The critical values only of the actions from cases 1–5 are shown in Table 5.1.

### 5.4.2 Beam design

(a)  
Roof beam 13–14–15

Moment  $M_{14-13} = -391 \text{ kNm}$  (Table 5.1)

Shear  $S_{14-13} = 255 \text{ kN}$

See Floor beam design. Select  $457 \times 191 \text{ UB } 67$ .

**Table 5.1** Design action 5

<i>(a) Beam</i>				
Load case	Member critical section	Moment, $M$ (kNm)	Shear, $F$ (kN)	Unrestrained length, <sup>a</sup> $l$ (m)
1	Roof beam 13–14	$M_{14-13} = -391$	$F_{14-13} = 255$	1.94
5	Floor beam 10–11	$M_{11-10} = -566$	$F_{11-10} = 366$	1.94

<sup>a</sup>The unrestrained length of compression flange occurs on the underside of the beam at the support (Figure 5.6).

<i>(b) Column</i>				
Load case	Member critical section	Moment, $M$ (kNm)	Thrust, $F$ (kN)	
2	Outer column 10–7	$M_{10-7} = -77$	$M_{7-10} = 68.3$	$F_{10-7} = 596.2$
3	Outer column 7–4	$M_{7-4} = -172.5$	$M_{4-7} = 170.9$	$F_{7-4} = 962.5$
4	Outer column 4–1	$M_{4-1} = 62.2$	$M_{1-4} = 0$	$F_{4-1} = 1322.9$
2	Centre column 11–8	$M_{11-8} = 23.1$	$M_{8-11} = -20.7$	$F_{11-8} = 1087.1$
1	Centre column 5–8	$M_{5-8} = 0$	$M_{8-5} = 0$	$F_{5-8} = 1223.4$

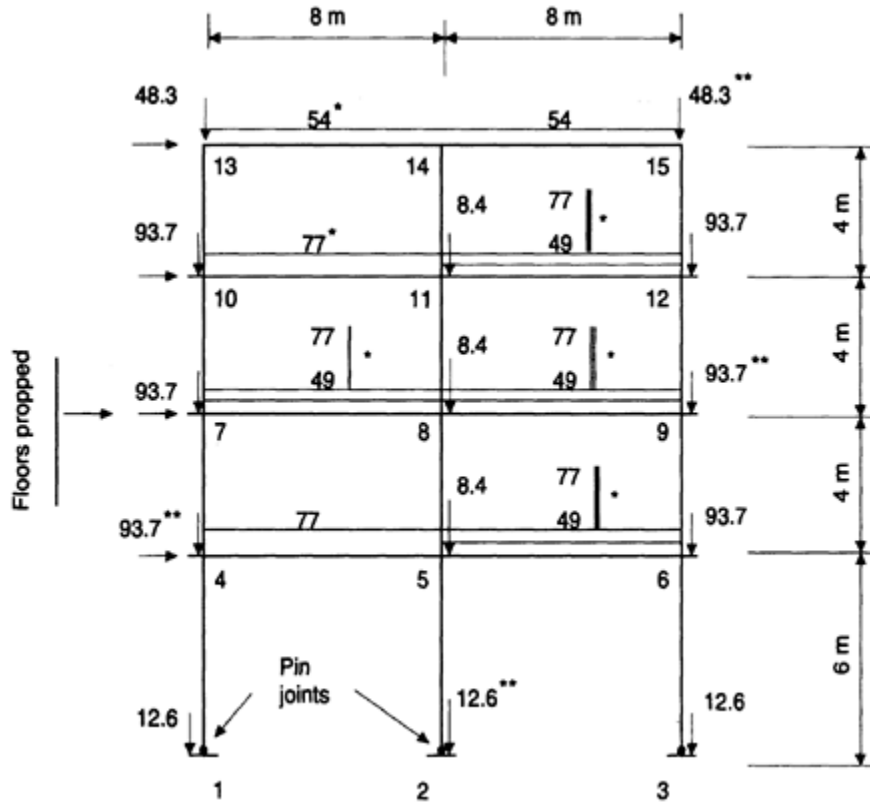

\*Uniform loads: 54, 49, 77 kN/m  
 \*\*Point loads: 48.3, 93.7, 12.6 kN  
 □\*Dead+Imposed: 77 kN/m; dead only=49 kN/m  
 External columns—weight between floors=19.4 kN  
 (a)

Members	$A(\text{cm}^2)$	$I(\text{cm}^4)$
4-5-6, 7-8-9, 10-11-12	118	55400
13-14-15	96	33400
1-4-7, 3-6-9	114	14300
2-5-8	137	17500
7-10-13, 8-11-14, 9-12-15	58.8	4560

(b)

Fig. 5.5 Braced frame—computer analysis data: (a) dimensions and frame loads; (b) areas and moments of inertia.

(b) Column

Load case	Member critical section	Moment, $M$ (kNm)		Thrust, $F$ (kN)
1	Centre column 2-5	$M_{2-5}=0$	$M_{5-2}=0$	$F_{2-5}=2610.2$
4	Centre column 2-5	$M_{5-2}=22.9$	$M_{2-5}=0$	$F_{5-2}=2473.2$
5	Centre column 2-5	$M_{5-2}=25$	$M_{2-5}=0$	$F_{5-2}=2393$

(b)

Floor beam 10-11-12

Moment  $M_{11-10}=546$  kNm (Figure 5.6(b))      Shear  $F_{11-10}=359$  kN       $S=566 \times 10^3 / 275 = 2050 \text{ cm}^3$   
 Try 533×210 UB 82, with  $S=2060 \text{ cm}^3$ ,  $r_y=4.38 \text{ cm}$ ,  $u=0.856$ ,  $x=41.6$ ,  $I=47500 \text{ cm}^4$ ,  $D=528.3 \text{ mm}$ ,  $t=9.6 \text{ mm}$ ,  $T=13.2 \text{ mm}$ ,  
 $p_y=275 \text{ N/mm}^2$ .

Unrestrained length of compression flange=1.94 m

$M_0=77 \times 1.94^2 / 8 = 36$  kNm (Tables 16 and 17)

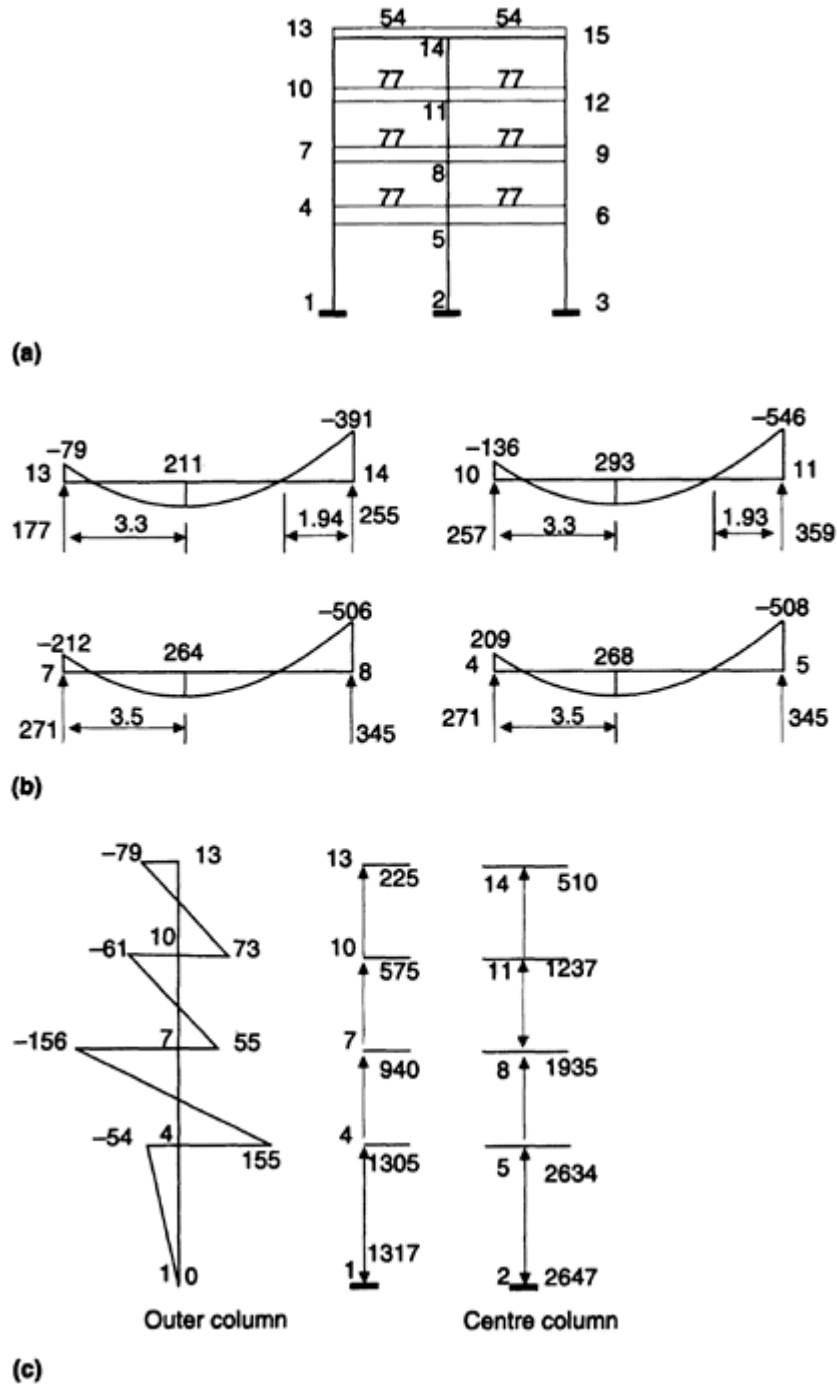

Fig. 5.6 Computer analysis results for case 1: (a) beam loads (kNm); (b) beam moments (kNm) and shears (kN); (c) column moments (kNm) and thrusts (kN).

$$\begin{array}{l}
 \gamma = -566/36 = -15.44 \\
 \lambda = 194/4.38 = 44.3 \\
 \lambda/x = 44.3/41.6 = 1.06 \\
 \nu = 0.99 \text{ (Table 14)} \\
 \lambda_{LT} = 0.67 \times 0.856 \times 0.99 \times 44.3 = 25.2 \\
 p_b = 275 \text{ N/mm}^2 \text{ (Table 11)} \\
 \text{Shear capacity } P_v = 0.6 \times 275 \times 528 \times 3 \times 9.6/10^3 = 836.8 \text{ kN}
 \end{array}$$

The maximum shear, 359 kN, is therefore not high enough to affect the moment capacity (Clause 4.2.5).

Simple beam deflection due to the imposed load

$$\begin{aligned}
 &= 3.5 \times 8 \times 5 = 140 \text{ kN} \\
 \delta &= \frac{5 \times 140 \times 10^3 \times 8000^3}{384 \times 205 \times 10^3 \times 47500 \times 10^4} = 9.6 \text{ mm} \\
 &< \text{span}/360 = 22.2 \text{ mm}
 \end{aligned}$$

The beam is satisfactory. All beams to be the same.

### 5.4.3 Column design

(a)

Outer column—upper length 7–10–3

Critical actions from Table 5.1 are

Moment  $M_{10-7}=77 \text{ kNm}$

Thrust  $F_{10-7}=596.2 \text{ kN}$

Select 203×203 UC 47. See design for lower column length below.

(b)

Outer column—lower length 1–4–7

Critical actions at sections 7–4 and 4–1 from Table 5.1 from cases 3 and 4 are

$M_{7-4}=-172.5 \text{ kNm}$ ;  $F_{7-4}=962.9 \text{ kN}$

$M_{4-1}=-62.2 \text{ kNm}$ ;  $F_{4-1}=1322.9 \text{ kN}$

Try 254×254 UC 89, with  $r_y=6.52 \text{ cm}$ ,  $S_x=1230 \text{ cm}^3$ ,  $A=114 \text{ cm}^2$ ,  $x=14.4$ ,  $u=0.849$ ,  $T=17.3 \text{ mm}$ ,  $p_y=265 \text{ N/mm}^2$ .

For length 7–4 (=4.0 m):

$$\lambda=52.1$$

$$p_c=205.8 \text{ N/mm}^2$$

$$\lambda/x=3.62 \nu=0.883 \lambda_{LT}=39.1 p_b=255.9 \text{ N/mm}^2 M_b=314.9 \text{ kNm} M_c=325.9 \text{ kNm} m=0.43$$

Local capacity  
check=0.85

Overall buckling  
check=0.67

For length 1–4 (=6.0 m):

$$\lambda=78.2 \quad p_c=160.6 \text{ N/mm}^2$$

$$\lambda/x=5.43 \nu=0.796 \lambda_{LT}=52.8$$

$$p_b=224.3 \text{ N/mm}^2$$

$$M_b=275.9 \text{ kNm} \beta=0 m=0.57$$

Local capacity  
check=0.63

Overall  
buckling  
check=0.87

The section is satisfactory.

(c)

Centre column—upper length 8–11–4

The critical actions from Table 5.1 are

$M_{11-8}=23.1 \text{ kNm}$ ;  $F_{11-8}=1087.1 \text{ kN}$

$M_{5-8}=0$ ;  $F_{5-8}=1223.4 \text{ kN}$

Select 203×203 UC 52.

(d)

Centre column lower length 2–5–8

The critical actions from Table 5.1 are

$M_{5-2}=25 \text{ kNm}$ ;  $F=2393 \text{ kN}$

$M_{5-2}=22.9 \text{ kNm}$ ;  $F_{5-2}=2473.2 \text{ kN}$

$M_{2-5}=0$ ;  $F_{2-5}=2610.2 \text{ kN}$

Try 305×305 UC 118, with  $r_y=7.76 \text{ cm}$ ,  $S_x=1950 \text{ cm}^3$ ,  $A=150 \text{ cm}^2$ ,  $x=16.2$ ,  $u=0.851$ ,  $T=18.7 \text{ mm}$ ,  $p_y=265 \text{ N/mm}^2$ .

For length 5–2 (=6.0 m):

$$M=22.9 \text{ kNm} \quad F=2473.2 \text{ kN}$$

$$\lambda=65.7 \quad p_c=178.6 \text{ N/mm}^2$$

$$\lambda/x=4.06 \nu=0.858 \lambda_{LT}=47.9$$

$$p_b=235.6 \text{ N/mm}^2 \quad M_b=459.4 \text{ kNm}$$

$$\beta=-0.47 m=0.57$$

Local  
capacity  
check=0.64

Overall  
buckling  
check=0.96

For length 2–5 (base):

$$P_c=150 \times 178.6/10=2679 \text{ kN} > 2610.2 \text{ kN}$$

The section is satisfactory.

#### 5.4.4 Joint design

One typical joint for the floor beams at the centre column only is designed.

(a)  
Critical actions at joint II (see Table 5.1)

Moment  $M_{11-10}=546$  kNm

Shear  $F_{11-10}=359$  kNm

(b)  
Frame section and joint arrangement

Column 8–11–14 uses 203×203 UC 52; beam 10–11–12 uses 533×210 UC 82. The proposed arrangement of the joint is shown in Figure 5.7.

(c)  
Bolt size

The top six bolts are assumed to resist tension with equal values  $T$  for the top two rows. Thus the moment

$$546=(4T \times 0.85)+2T \times 0.71^2/0.8$$

$$T=117.2 \text{ kN}$$

$$\text{Shear on bottom four bolts}=359/4$$

$$=89.8 \text{ kN}$$

Provide 22 mm dia. Grade 8.8 bolts, with

$$\text{Tension capacity}=136 \text{ kN}$$

$$\text{Single shear capacity}=114 \text{ kN}$$

(d)  
Beam end plate thickness

The yield line pattern is shown in Figure 5.8(b). For the top bolts:

$$((208.7 \times 2) - 48)M' \quad \Theta = 2 \times 117.2 \times 400 \times 10^3$$

$$M' = 25381 = 265 \times t^2/4$$

$$t = 19.5 \text{ mm}$$

Provide 20 mm plate.

(e)  
Column flange plate check

Increase the upper column section to 203×203 UC 60. (Figures 5.7 and 5.8 show the dimension and the yield line pattern.) For 203×302 UC 60,  $A=75.8$  cm<sup>2</sup>,  $B=205.2$  mm,  $t=9.3$  mm,  $T=14.2$  mm,  $r=10.2$  mm.

The check is made on the upper column length 11–14 above joint 11. The yield line analyses gives

$$(100+(2 \times 40.2))M' \quad \Theta + 2(87.75+28.4)0.7M' \quad \Theta + 40.6 \times 1.4M' \quad \Theta = 117.2 \times 10^3 \times 35.15 \Theta$$

The yield line moment is

$$M' = 10304 \text{ Nmm/mm}$$

The flange resistance moment is

$$M'_c = 275 \times 14.2^2/4 = 13863 \text{ Nmm/mm}$$

The frame actions at joint II from computer analysis are

$$F_{11-14}=518.4 \text{ kN}; M_{11-14}=0$$

Combined:

$$\frac{518.4 \times 10}{75.8 \times 275} + \frac{10304}{13863} = 0.98$$

This is satisfactory. Note that the column flange could have been strengthened by a backing plate instead of increasing the column section.



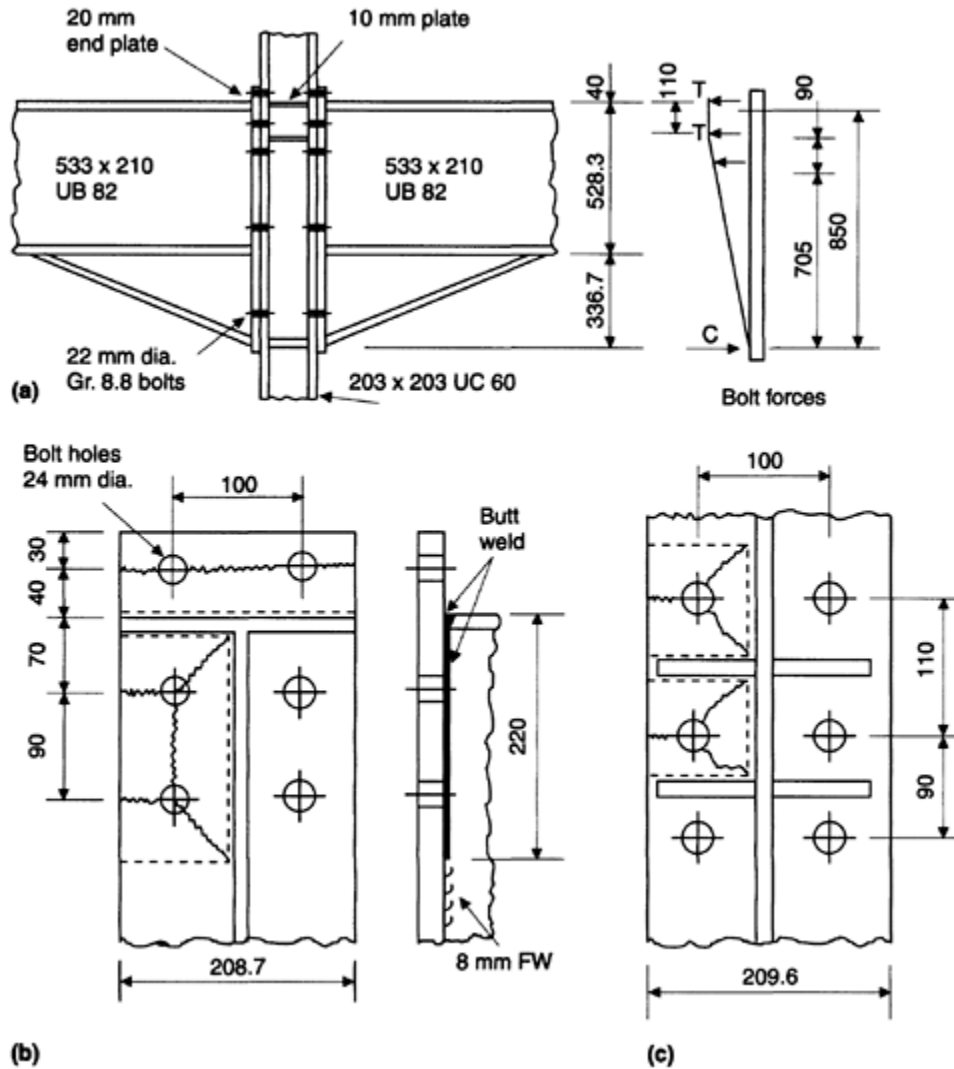

Fig. 5.7 Floor beam—centre column joint: (a) joint arrangement; (b) beam endplate; (c) column flange.

5.5

## BRACED RIGID PLASTIC DESIGN

### 5.5.1

#### Design procedure

The plastic design method for non-sway frames is set out in Clause 5.7.2 of BS 5950. This clause specifies that the frame should have an effective bracing system independent of the bending stiffness of the frame members. The columns are to be checked for buckling resistance in accordance with Clause 4.8.3.3, Design of Compression Members with Moments.

The above code provisions indicate the following.

- Beams are designed for fixed end plastic moments—

$$M_p = WL/16$$

where  $W$  is the design load.

- Columns are designed to provide sufficient resistance for plastic hinges to form in the beams. In pre-limit state terminology, they are designed to remain elastic.

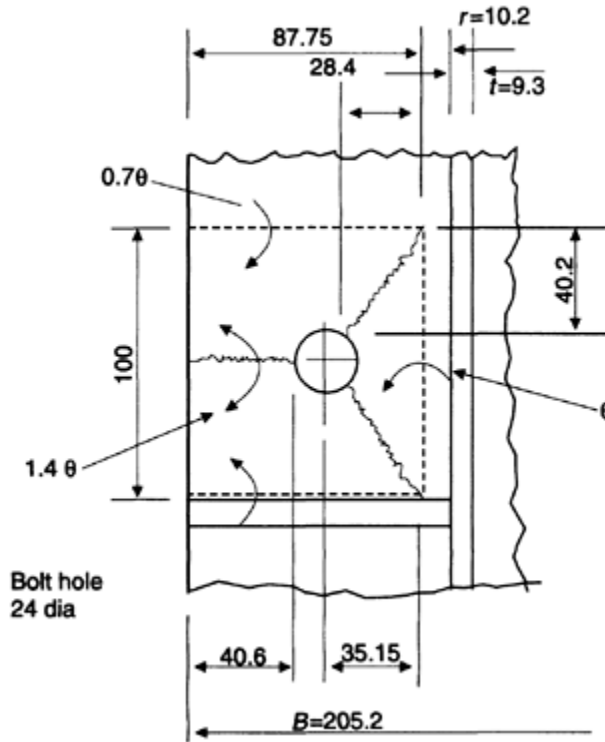

Fig. 5.8 Column flange top bolt yield line pattern.

Plastic hinges form at the beam ends. The beam-to-column connections can be made using either full-strength welds or high-strength bolts. Bolted connections designed to have a higher capacity than the beam plastic moment will be adopted in the design. An allowance is made for eccentricity of the joint and local joint actions are taken into account.

The braced frame specified in section 5.2 above is designed to plastic theory. The frame dimensions and loads are shown in Figure 5.5.

### 5.5.2 Design loads and moments

(a)  
Load patterns (Figure 5.9)

Load patterns are arranged to give

- Total design load  $W=(1.4 \times \text{dead})+(1.6 \times \text{imposed})$  on all beams for beam design and beams in external bays for design of external columns;
- total design load  $W$  on any beam and factored dead load on selected adjacent beams to give maximum moments in internal columns.

(b)  
Analysis for beam and column moments

#### (i) Roof beam—external column (Figure 5.9 (a))

If the beam plastic moment  $M_{pb}$  exceeds the known column plastic moment  $M_{pc}$ , then the shear is zero at the centre hinge Y. Take moments about ends X and Z to give

$$M_{pb} = (wx^2/2) - M_{pc} \qquad 2M_{pb} = w(L-x)^2/2$$

where  $w$  is the design load on the roof beam (kN/m).

Solve for  $x$  and calculate  $M_{pb}$ .

If  $M_{pc} > M_{pb}$  then  $M_{pb} = wL^2/16$

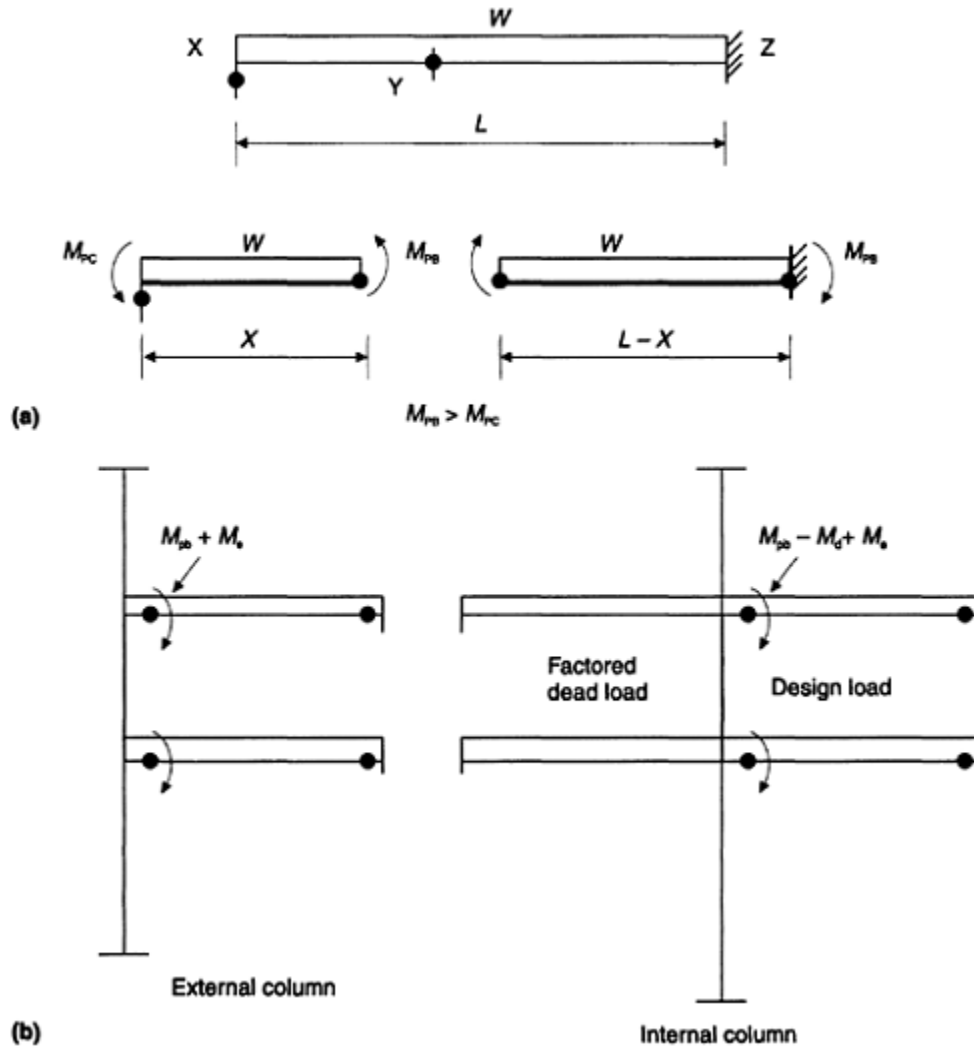

Fig. 5.9 Load patterns: (a) external roof beam; (b) column subframes ( $M_e$ = moment due to eccentricity;  $M_d$ =moment due to factored dead load).

(ii) All other beams

$$M_{pb} = wL^2/16$$

Column subframes

The subframes for determining the column moments are shown in Figure 5.9(b) for external and internal columns. Loads must be arranged in an appropriate pattern for the internal column. An allowance for eccentric end connections is made.

5.5.3  
Frame design

(a)  
Roof beam (Figure 5.6(a))

Assume that the moment capacity of the external column is greater than that of the roof beam:

$$M_{pb} = 54 \times 8^2 / 16 = 216 \text{ kNm}$$

$$S_x = 216 \times 103 / 275 = 785 \text{ cm}^3$$

Select 406×140 UB 46, with  $S_x = 888 \text{ cm}^3$ .

(b)  
Floor beam (Figure 5.5(a))

$$M_{pb} = 77 \times 8^2 / 16 = 308 \text{ kNm}$$

$$S_x = 308 \times 10^3 / 275 = 1120 \text{ cm}^3$$

Try 457 × 152 UB 60, with  $S_x = 1280 \text{ cm}^3$ ,  $I_x = 25\,500 \text{ cm}^4$ .

$$\text{Shear } F = 308 \text{ kN}$$

$$P_v = 0.6 \times 275 \times 454.7 \times 8 / 10^3 = 600.2 \text{ kN}$$

Deflection due to the imposed load is 17.5 kN/m on a fixed end beam.

$$\begin{aligned} \delta &= \frac{17.5 \times 8000^4}{384 \times 205 \times 10^3 \times 25\,500 \times 10^4} = 3.57 \text{ mm} \\ &= \text{Span} / 2240 \end{aligned}$$

The beam would also be satisfactory if it were simply supported.

(c)  
External column—upper length 7–10–13

The loads and moments applied to the column are shown in Figure 5.10(a).

$$\text{Beam end plastic moment} = 308 \text{ kNm}$$

This connection moment will be greater than 308 kNm because this moment is assumed to be developed at an eccentricity of 100 mm from the column face.

Assume column length 7–10–3 is 254 × 254 UC 73, with  $I = 11\,400 \text{ cm}^4$  and length 1–4–7 is 305 × 305 UC 97, with  $I = 22\,200 \text{ cm}^4$ .

The beam moments are

$$M_{10-11}^F = 308 + (308 \times 0.23) = 378.8 \text{ kNm}$$

$$M_{7-8}^F = 308 + (308 \times 0.26) = 388 \text{ kNm}$$

The subframe for determining the column moments is shown in Figure 5.10(a). The distribution factors for joints 10 and 7 are

$$K_{10-13}: K_{10-7} = 0.5:0.5$$

$$K_{7-4}: K_{7-10} = \frac{22\,200:11\,400}{33\,600} = 0.66:0.34$$

The moment distribution is carried out. The design actions at joint 10 are

$$\text{Thrust: } F_{10-7} = 660 \text{ kN}$$

$$\text{Moments: } M_{10-7} = 213.8 \text{ kNm}$$

$$M_{7-10} = 181.6 \text{ kNm}$$

Try 254 × 254 UC 89, with  $t = 10.5 \text{ mm}$ ,  $T = 17.3 \text{ mm}$ ,  $D = 260.4 \text{ mm}$ ,  $d/t = 19.1$ ,  $A = 114 \text{ cm}^2$ ,  $S_x = 1230 \text{ cm}^3$ ,  $Z_x = 1100 \text{ cm}^3$ ,  $p_y = 265 \text{ N/mm}^2$ . Refer to column check in section 5.4.3(b). For case here

$$p_c = 205.9 \text{ N/mm}^2, M_c = 325.9 \text{ kNm (gross value, see below)}, M_b = 314.9 \text{ kNm}, m = 0.43, \text{Local capacity check} = 0.86, \text{Overall buckling check} = 0.57$$

The proposed arrangement for joint 10 is shown in Figure 5.11. The bolt tension due to the plastic moment (308 kNm) and moment due to eccentricity of 100 mm (30.8 kNm) is

$$308 + 30.8 = 338.8 \text{ kNm}$$

$$338.8 = (4T \times 0.53) + (2T \times 0.39^2 / 0.48)$$

$$T = 123 \text{ kN}$$

Provide 22 mm dia. Grade 8.8 bolts. Tension capacity is 136 kN and shear 114 kN/bolt. Shear of lower four bolts =  $4 \times 114 = 456 \text{ kN}$ . This ensures that the hinge forms in the beam. The haunch is small.

Refer to section 5.4.4(e). The column flange can be checked in the same way:

$$\text{Yield line moment} = 123 \times 9779 / 111 = 10836 \text{ Nmm/mm}$$

$$\text{Flange capacity} = 265 \times 17.3^2 / 4 = 19828 \text{ Nmm/mm}$$

Above floor 10–11–12:

$$\begin{aligned} F_{10-13} &= 283.7 \text{ kN}, M_{10-13} = 165.3 \text{ kNm} \\ \text{capacity check: } &+ \frac{283.7 \times 10}{265 \times 114} - \frac{165.3}{325.9} \pm \frac{10836}{19828} = 0.96 \end{aligned}$$

This is satisfactory.

Check column web for shear:

$$\text{Web shear } F_v = 123 \times 4 + 0.81 \times 123 \times 2 = 691 \text{ kN}$$

$$\text{Web capacity } P_v = 0.6 \times 265 \times 260.4 \times 10.5 / 10^3$$

$$= 434.7 \text{ kN}$$

Add 8 mm double plate to increase shear capacity of the column web.

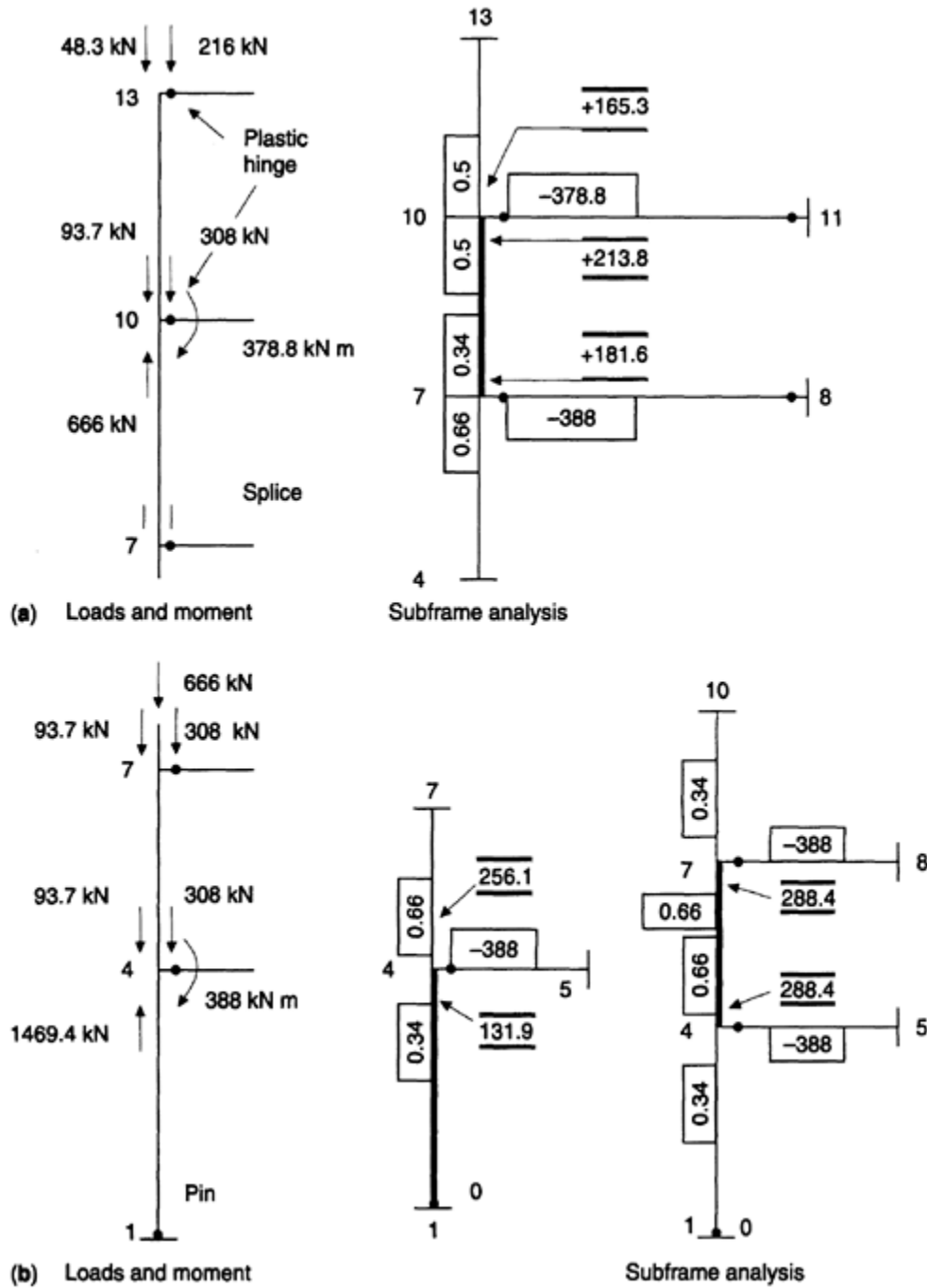

Fig. 5.10 External column design: (a) upper length 7–10–13; (b) lower length 1–4–7.

(d)  
External column-lower length 1–4–7

Refer to Figure 5.10(b). Assume column is 305×305 UC. Moment due to eccentricity is

$$308 \times 0.26 = 80 \text{ kNm}$$

$$\text{Total moment} = 388 \text{ kNm,}$$

Check column length 1–4, length 6 m. See subframe in Figure 5.10. The distribution factors allowing for the pin-end joint 1 are

$$K_{1-4} : K_{4-7} = \frac{\frac{3}{4} \times \frac{1}{6} : \frac{1}{4}}{0.375} = 0.33 : 0.66$$

The moment distribution may be carried out to give the design actions:

$$M_{4-1} = 131.9 \text{ kNm}$$

$$F_{4-1} = 1469 \text{ kN}$$

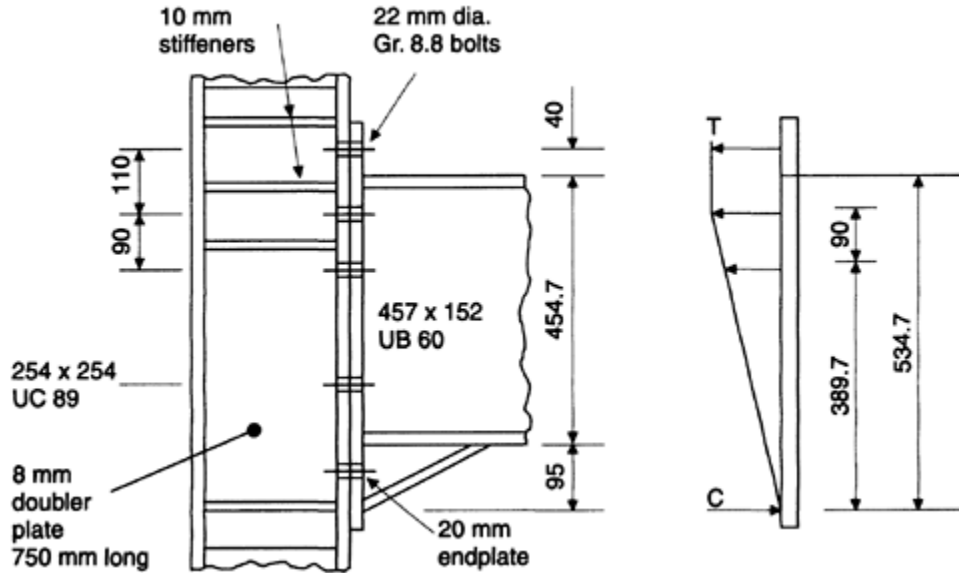

Fig. 5.11 Joint to external column (joints to internal columns similar)

Try 305×305 UC 97, with

$$T=15.4 \text{ mm}, p_y=275 \text{ N/mm}^2, p_c=188.2 \text{ N/mm}^2, A=123 \text{ cm}^2, M_c=437.2 \text{ kN m}, M_b=374.6 \text{ kNm}, m=0.57.$$

$$\text{Local capacity check}=0.73$$

$$\text{Overall buckling check}=0.83$$

Check column length 4–7, length 4 m. The design actions of joint 4 are

$$F_{4-7}=1087.1 \text{ kN}, M_{4-7}=288.4 \text{ kN m}$$

$$\text{Local capacity check}=0.98$$

$$\text{Overall buckling check}=0.67$$

The column flange can be checked above joint 4. A check such as carried out in (c) above will show the section to be satisfactory.

The web will require strengthening with a doubler plate as set out in (c).

(e)

Centre column—upper length 8–11–14

The loads and moments and subframe are shown in Figure 5.12(a). Assume column 8–11–14 is 203×203 UC 60,  $I=6090 \text{ cm}^4$  and 2–5–8 is 305×305 UC 118,  $I=27600 \text{ cm}^4$ .

The beam fixed end moments and the moments are found as follows. Beams 10–11 and 7–8 carry full design load of 77 kN/m:

$$M_{11-10}^F = (77 \times 64/16) + (77 \times 4 \times 0.21) = 372.7 \text{ kN m}$$

$$M_{8-7}^F = 308 + (308 \times 0.26) = 388 \text{ kN m}$$

Beams 11–12 and 8–9 carry the factored dead load of 49 kN/m:

$$M_{11-12}^F = (49 \times 64/12) + (49 \times 4 \times 0.21) = 302.5 \text{ kN m}$$

$$M_{8-9}^F = 261.3 + (196 \times 0.26) = 312.3 \text{ kN m}$$

The distribution factors are:

$$K_{11-14} : K_{11-12} : K_{11-8} = \frac{6090/400 : 25\,500/800 : 6090/400}{15.2 + 31.9 + 15.2} = 0.24 : 0.52 : 0.24$$

$$K_{8-11} : K_{8-9} : K_{8-5} = \frac{6090/400 : 25\,500/8 : 27\,600/400}{15.2 + 31.9 + 69} = 0.13 : 0.27 : 0.6$$

The results of the moment distribution are

$$M_{11-8} = -24.6 \text{ kNm}$$

$$M_{8-11} = -8.7 \text{ kNm}$$

$$F_{11-8} = 944.4 \text{ kN}$$

Alternatively the hinge in the lower beams could be located in beam 8–9. This gives  $M_{11-8} = +13.1 \text{ kNm}$ ,  $M_{8-11} = -2.5 \text{ kNm}$ . Try 203×203 UC 60, with  $p_c=190 \text{ N/mm}^2$ ,  $A=75.8 \text{ cm}^2$ ,  $M_b=160.9 \text{ kNm}$ ,  $M_c=179.2 \text{ kNm}$ ,  $m=0.47$ ,  $T=14.2 \text{ mm}$ ,  $p_y=275 \text{ N/mm}^2$ .

$$\text{Local capacity check}=0.61$$

$$\text{Overall buckling check}=0.73$$

The beam end moment causing tension in the bolts is

$$M_{11-10} = 308 + 30.8 = 338.8$$

$$T = 123 \text{ kN (section 5.6.3(c))}$$

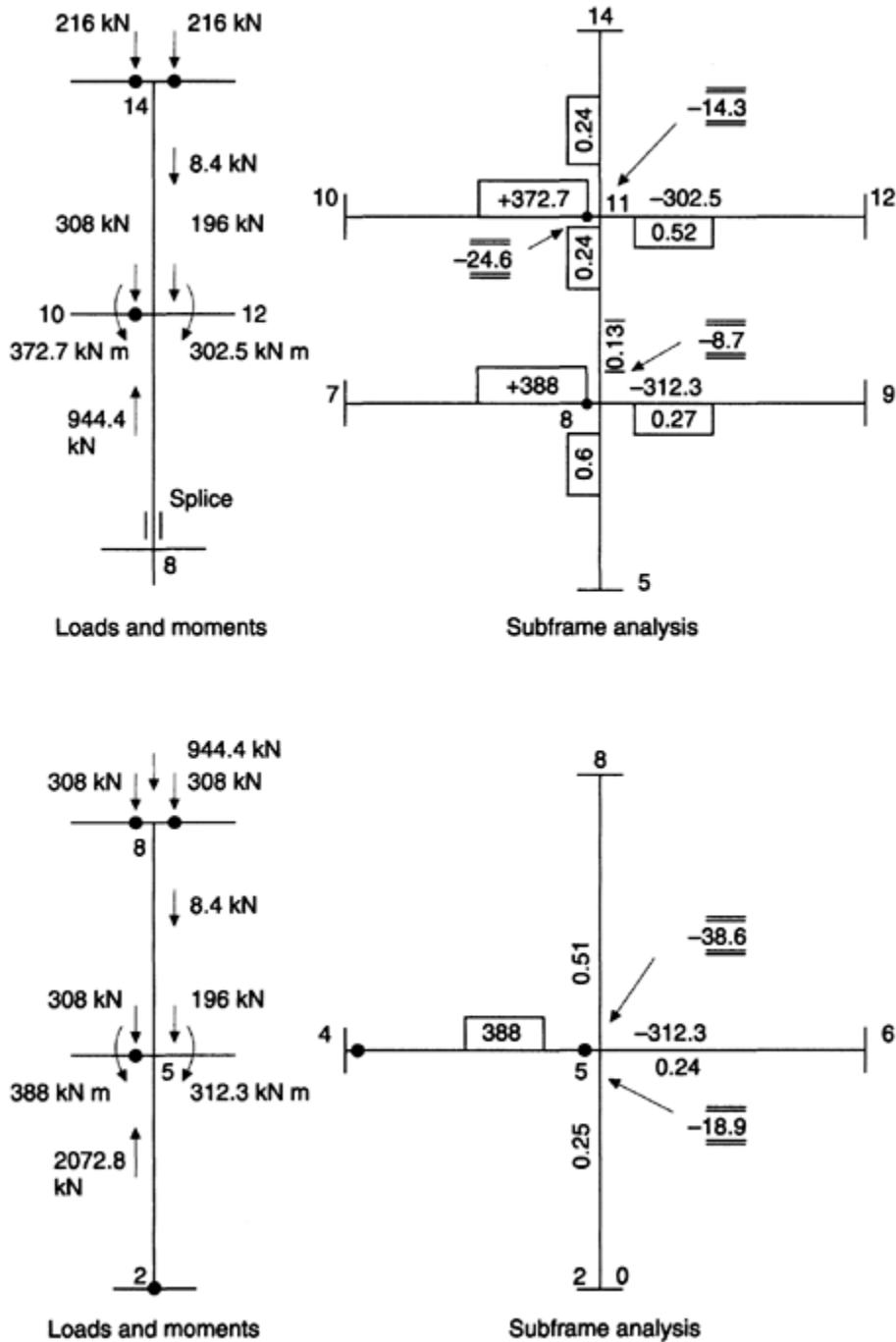

Fig. 5.12 Internal column design: (a) upper length 8–11–14; (b) lower length 2–5–8.

Refer to sections 5.4.4(c) and (e), joint 11.

$$\text{Yield line moment } M' = 123 \times 9779 / 111 = 10836 \text{ Nmm/mm}$$

$$\text{Flange capacity } M'_p = 13863 \text{ Nmm/mm}$$

For the column,

$$M_{11-14} = -14.3 \text{ kNm}$$

$$F_{11-14} = 440.4 \text{ kN}$$

Capacity check:

$$\frac{440.4 \times 10}{75.8 \times 275} - \frac{14.3}{179.2} \pm \frac{10863}{13862} = 0.96$$

This is satisfactory. The web shear capacity is also satisfactory.

(f)  
Centre column lower length 2–5–8

Loads and moments and subframe are shown in Figure 5.12(b). The beam fixed end moments are

$$M_{5-4}^F = 388 \text{ kN m}, M_{5-6}^F = 312.3 \text{ kN m}$$

The distribution factors allowing for the pin at 2 are

$$K_{5-8} : K_{5-6} : K_{5-2} = \frac{27\,600/400 : 25\,500/800 : 0.75 \times 27\,600/600}{69 + 31.9 + 34.5} \\ = 0.51 : 0.24 : 0.25$$

The results of the moment distribution are

$$M_{5-2} = 18.9 \text{ kNm}$$

$$F_{5-2} = 2072.8 \text{ kN}$$

Try 305×305 UC 97, with  $p_c = 188.2 \text{ N/mm}^2$ ,  $A = 123 \text{ cm}^2$ ,  $M_c = 437.2 \text{ kNm}$ ,  $M_b = 374.6 \text{ kNm}$ ,  $m = 0.57$ .

Local capacity check = 0.66

Overall buckling check = 0.92

The column flange above first floor level is also satisfactory, as is the web shear capacity.

The sections are summarized in Table 5.2 (section 5.7).

## 5.6

### SEMIRIGID DESIGN

#### 5.6.1

##### Code requirements

Semirigid design is permitted in both BS 5950 and Eurocode 3. The problem in application lies in obtaining accurate data on joint behaviour. A tentative semirigid design is made for the frame under consideration in order to bring out aspects of the problem. The design set out applies to braced structures only.

BS 5950 defines semirigid design in Clause 2.1.2.4 in terms that some degree of connection stiffeners is assumed insufficient to develop full continuity. The clause specifies that:

The moment and rotation capacity of the joints should be based on experimental evidence which may permit some limited plasticity providing the ultimate tensile capacity of the fastener is not the failure criterion

The code also gives an alternative empirical method based on the rules of simple design where an end restraint moment of 10% of the beam free moment may be taken in design.

Eurocode 3 specifies in Clause 5.2.2.4 design assumptions for semicontinuous framing for structures. This states that:

Elastic analysis should be based on reliably predicted design moment-rotation or force-displacement characteristics of the connections used.

Rigid plastic analysis should be based on the design moment resistances of connections which have been determined to have sufficient rotation capacity.

Elastic-plastic analysis can be used.

Eurocode 3 also permits in Clause 5.2.3.6 the use of suitable subframes for the global analysis of structures with semicontinuous framing.

Beam-to-column connection characteristics are discussed in Section 6.9 of Eurocode 3. The main provisions are summarized below:

- Moment-rotation behaviour shall be based on theory supported by experiment.
- The real behaviour may be represented by a rotational spring.
- The actual behaviour is generally nonlinear. However, an approximate design moment-rotation characteristic may be derived from a more precise model by adopting a curve including a linear approximation that lies wholly below the accurate curve.
- Three properties are defined by the moment-rotation characteristics (Figure 5.13):
  - Moment resistance  $M_R$ ;



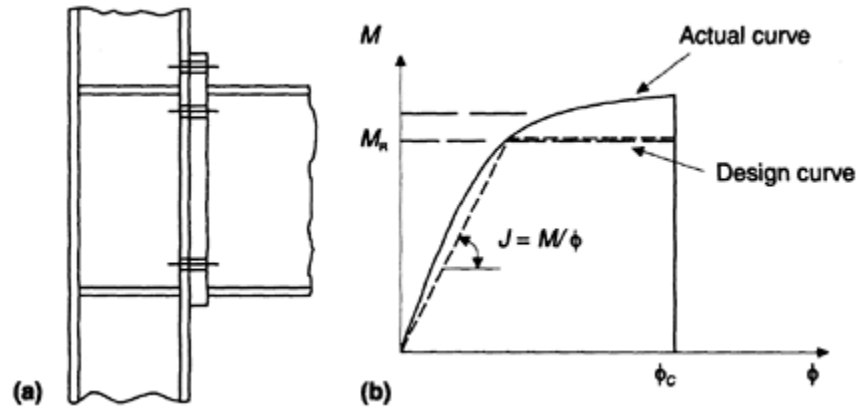

Fig. 5.13 Beam-to-column connection: (a) details; (b) moment-rotation curves.

- rotational stiffness-use secant stiffness  $J=M/\varphi$ ;
- rotation capacity  $\varphi_c$ .

### 5.6.2

#### Joint types and performance

Two possible arrangements for semirigid joints—flush and extended endplate types—are shown in Figure 5.14. In both cases the columns are strengthened with backing plates and stiffeners and the top bolts resisting moment are oversized. The endplates are sized as to thickness to fail at the design end moment.

The above provisions ensure that failure is not controlled by the bolts in tension and the major part of yielding occurs in the endplates and not in the column flange. Yield line failure patterns for the endplates in the two types of joint are shown in the figure, from which the failure loads can be readily calculated.

Analyses can be carried out to determine joint flexibility measured by the spring constant  $J=M/\varphi$ . The endplate and column flange can be modelled using the finite element method and bolt extension included to give total deformation. Joint rotation is assumed to take place about the bottom flange or haunch (Lothers 1960; Jenkins *et al.*, 1986; technical papers in Dowling *et al.*, 1987).

Only test results give reliable information on joint performance. The problem with using the data is that so many variables are involved that it is difficult to match the precise requirements of a given design problem to a test. BS 5950 is cautious in stressing that performance should be based on experimental evidence. Joint strengths can be higher than those predicted by yield line analysis due to plates resisting load in tension.

In the design example a value for joint flexibility, assessed from examining test results, will be used. Lothers (1960) and Jenkins (1986) quote values varying from 10000 to 20000 kNm/radian obtained by calculation and test for a variety of joints.

In the plastic design example given, the joint flexibility value is used only in the limited frame analysis for the centre column moments.

### 5.6.3

#### Frame analysis

(a)

##### Outline of methods

Analysis of frames with semirigid joints may be carried out by the following methods:

- elastic analysis where the joints are modelled by rotational springs, using
- moment distribution on the whole frame or on subframes,
- computer stiffness analysis;
- plastic analysis using joint moment resistance which is much less than the beam plastic capacity. The columns are designed to have adequate buckling resistance.

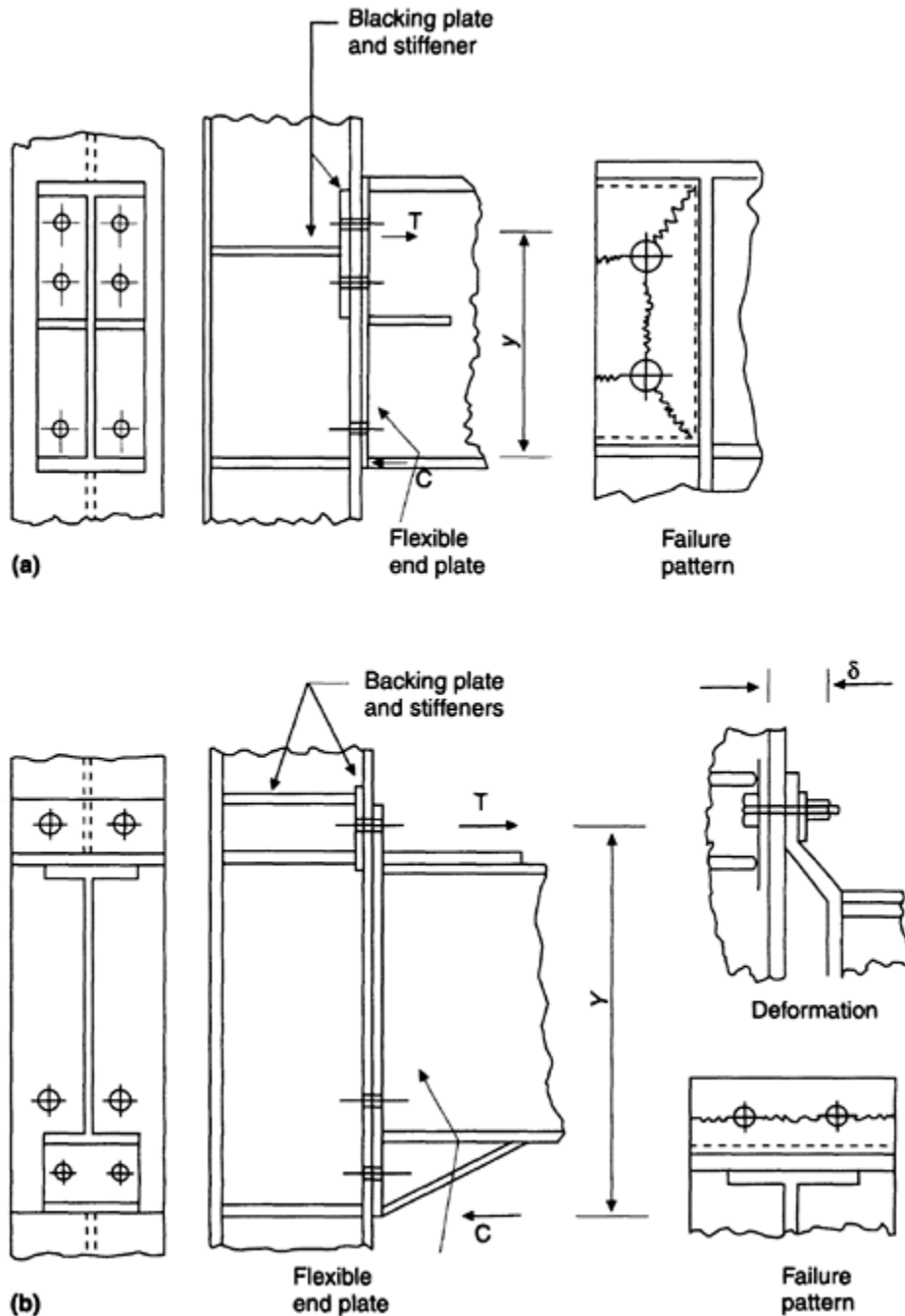

Fig. 5.14 Semirigid joints: (a) flush endplate connection; (b) extended endplate.

Plastic analysis will be adopted for the design example. It is, however, necessary to distribute out-of-balance moments at internal column joints in proportion to elastic stiffnesses. Expressions are derived below for fixed end moments, stiffnesses and carryover factors for beams with semirigid joints.

(b)  
Moment distribution factors

The moment-area theorems are used to determine the moment distribution factors. The factors are derived for a uniform beam with the same joint type at each end and carrying only uniform load. Lothers (1960) gives a comprehensive treatment of the problem.

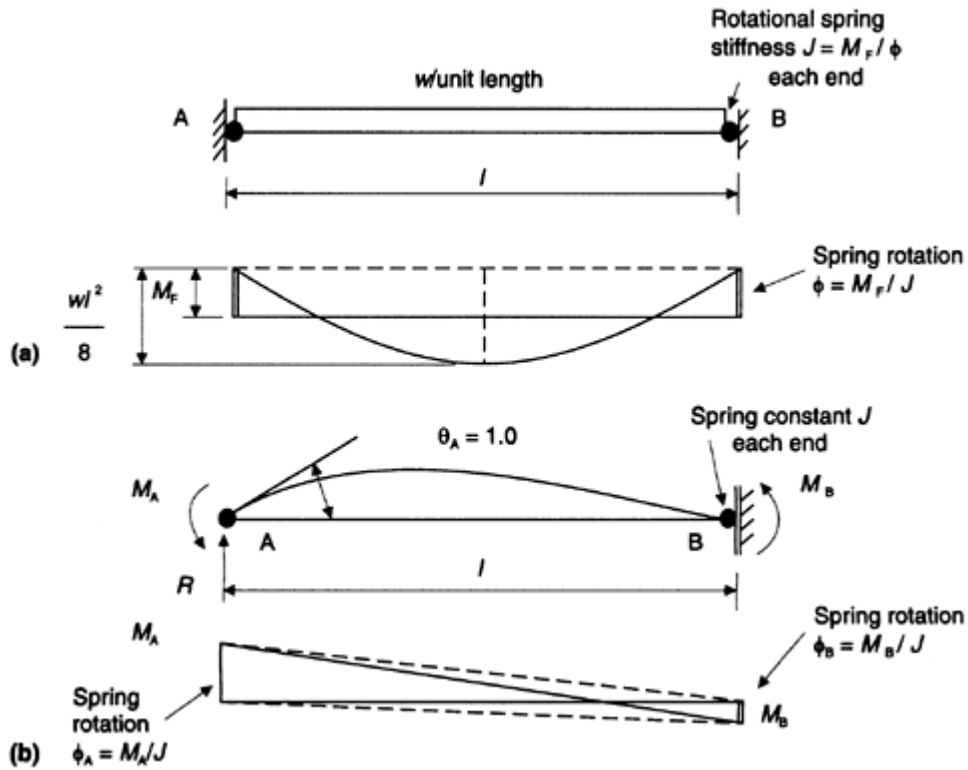

Fig. 5.15 Beam moments: (a) fixed end moments; (b) stiffness and carryover factor.

(i) Fixed end moments

There is no change in slope between the centre of the beam and the fixed ends (Figure 5.15(a)). That is, the area under the  $M/EI$  diagram plus spring rotation  $M_F/J$  is zero between stated points:

$$\frac{M_F l}{2EI} + \frac{M_F}{J} - \frac{wl^2}{8EI} \times \frac{2l}{3} \times \frac{1}{2} = 0$$

$$M_F = \frac{wl^3}{24EI} / \left( \frac{l}{2EI} + \frac{1}{J} \right)$$

where

- $M_F$ =fixed end moment
- $J$ =spring constant= $M/\phi$
- $E$ =Young's modulus
- $I$ =moment of inertia of the beam
- $w$ =beam loading
- $l$ =span.

(ii) Stiffness

Figure 5.15(b) shows a propped cantilever with springs at the ends subjected to a moment  $M_A$  causing a reaction  $R$  and slope  $\Theta_A$  at end A.

The stiffness at A is given by the value of  $M_A$  for rotation  $\Theta_A=1.0$ . Solve first for reaction  $R$  at A.

The deflection at A relative to the tangent at the fixed end B is zero. That is the moment of the areas of the  $M/EI$  diagram taken about A plus deflection due to the spring rotation at B caused by  $M_A$  and  $R$  is zero:

$$\frac{M_A l}{J} + \frac{M_A l^2}{2EI} - \frac{Rl^3}{3EI} - \frac{Rl^2}{J} = 0$$

$$R = M_A \left( \frac{1}{J} + \frac{l}{2EI} \right) / \left( \frac{l^2}{3EI} + \frac{l}{J} \right)$$

$$M_B = M_A - Rl$$

where  $M_B$  is the moment at end B.

The slope  $\Theta_A$  at A relative to the tangent at the fixed end B is equal to the area under the  $M/EI$  diagram between A and B plus the spring rotation at A due to moments  $M_A$  and  $M_B$ . This is given by

$$\Theta_A = 1 = \frac{M_A}{J} + \frac{M_A l}{2EI} - \frac{M_B}{J} - \frac{M_B l}{2EI}$$

Solve for  $M_A$  to obtain the absolute stiffness value. Divide this by  $4E$  to give the value in terms of  $(I/l)$  for a member without end springs.

**(iii) Carryover factor A to B**

This is given by

$$-\frac{M_B}{M_A} = -\left( \frac{M_A - Rl}{M_A} \right)$$

Note that for a uniform member with no end springs:

Stiffness =  $4EI/l \square I/l$

Carryover factor =  $+1/2$

The above factors can then be used in a normal moment distribution process to analyse a complete braced frame or a subframe.

**5.6.4  
Frame design**

(a)

*Specification*

The internal frame of the multistorey building shown in Figure 5.1 is to be designed with semirigid joints of 50% fixity. The building is braced and the design loading is shown in Figure 5.5.

Full plastic moment  $M_p = wl^2/16$

50% fixity  $M_f = wl^2/32$

(b)

*Roof beam*

Design load = 54 kN/m At support,  $M_f = 54 \times 8^2 / 32 = 108$  kNm At centre,  $M_c = wl^2 / 8 = 108 = 324$  kNm  $S = 324 \times 10^3 / 275 = 1178$  cm<sup>3</sup>.  
Select 457 × 157 UB 60, with  $S = 1200$  cm<sup>3</sup>.

(c)

*Floor beam*

Design load = 77 kN/m At support,  $M_f = 154$  kNm At centre,  $M_c = 462$  kNm  $S = 1743$  cm<sup>3</sup> for  $p_y = 265$  N/mm<sup>2</sup>  
Try 457 × 152 UB 82, with  $S = 1800$  cm<sup>3</sup>,  $I_x = 36200$  cm<sup>4</sup>. Check the deflection due to the imposed load of 17.5 kN/m on a simply supported beam:

$\delta = 5wl^4 / 384EI_x = 12.6$  mm

= Span / 635 < Span / 360

This is satisfactory.

(d)

*External column upper length 7-10-13*

The column loads and moments are shown in Figure 5.16 (a). Assume the following sizes for the columns: 7-10-13, 203 × 203 UC; 7-4, 254 × 254 UC. The fixed end moments allowing for eccentricity are

$$M_{10-11}^F = 154 + 308 \times 0.11 = 187.8 \text{ kN m}$$

$$M_{7-8}^F = 154 + 308 \times 0.13 = 194.0 \text{ kN m}$$

The subframe for determining the column moments for length 7–10 is shown in the figure. The distribution factors are

$$K_{10-13}:K_{10-7}=0.5:0.5$$

For 10–7 (203×203 UC 60),

$$I=6090 \text{ cm}^4, I/L=15.2$$

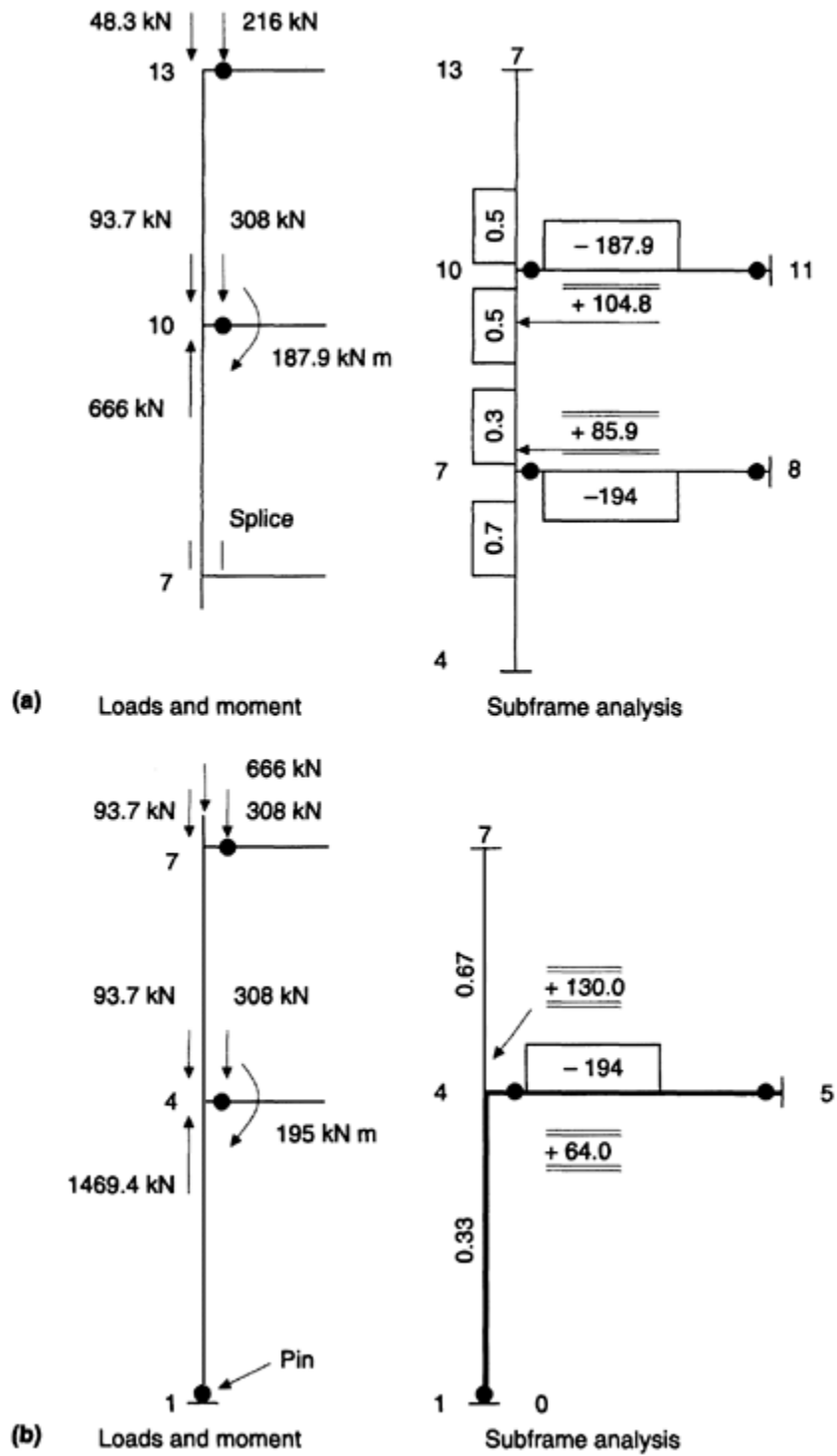

Fig. 5.16 External column design: (a) upper length 7–10–13; (b) lower length 1–4–7.

For 7–4 (254×254 UC 89),

$$I=14300 \text{ cm}^4, I/L=35.8$$

$$K_{10-7}:K_{7-4}=15.2:35.8/51=0.3:0.7$$

The moment distribution is carried out. The design actions at joint 10 are

$$F=666 \text{ kN}$$

$$M=104.8 \text{ kNm}$$

Try 203×203 UC 60, (Section 5.4.3(a)), with  $P_c=190 \text{ N/mm}^2$ ,  $A=75.8 \text{ cm}^2$ ,  $M_c=179.3 \text{ kNm}$ ,  $M_b=160.9 \text{ kNm}$ ,  $m=0.43$ .

$$\text{Local capacity check}=0.9$$

$$\text{Overall buckling check}=0.74$$

This is satisfactory.

(e)  
External column—lower length 1–4–7

Assume 254×254 UC where the moment due to eccentricity is  $308 \times 0.13 = 40$  kNm.

Total moment = 194 kNm.

The column loads and moment and subframe for length 1–4 are shown in Figure 5.16(b). The distribution factors taking account of the pin end 1 are

$$K_{1-4} : K_{4-7} = \frac{\frac{3}{4} \times \frac{1}{6} : \frac{1}{4}}{0.375} = 0.34 : 0.66$$

The results of the moment distribution are

$$M_{4-1} = 64.0 \text{ kNm}$$

$$M_{4-7} = 130.0 \text{ kNm}$$

$$F_{4-1} = 1469.4 \text{ kN}$$

Try 254×254 UC 89, with  $T=17.3$  mm,  $p_y=265$  N/mm<sup>2</sup>,  $p_c=160.2$  N/mm<sup>2</sup>,  $A=114$  cm<sup>2</sup>,  $M_c=325.9$  kNm,  $M_b=314.9$ ,  $M=0.57$  (Section 5.4.3(b)).

Local capacity check = 0.69

Overall buckling check = 0.93

Section is satisfactory. Length 4–7 is not as highly stressed.

(f)  
Centre column—upper length 8–11–14

Assume column 8–11–14 (Figure 5.17(a)) is 203×203 UC and 8–5 is 305×305 UC. The fixed end moments are

$$M_{11-10}^F = 154 + 308 \times 0.11 = 187.8 \text{ kNm}$$

$$M_{8-7}^F = 154 + 308 \times 0.16 = 203.3 \text{ kNm}$$

The fixed end moment for span 11–12 is calculated assuming a spring constant  $J=M/\phi=8000$  kNm/radian. The factored dead load on the span is 49 kN/m. (Section 5.6.3(b)). The fixed end moment:

$$\begin{aligned} M_{11-12} &= \left( \frac{49 \times 8000^3}{24 \times 205 \times 10^3 \times 36\,200 \times 10^4} \right) / \\ &\quad \left( \frac{8000}{2 \times 205 \times 10^3 \times 36\,200 \times 10^4} + \frac{1}{8000 \times 10^6} \right) \\ &= 78.8 \times 10^6 \text{ N mm} = 78.8 \text{ kNm} \end{aligned}$$

The fixed end moments are

$$M_{11-12}^F = 78.8 + 49 \times 4 \times 0.11 = 100.4 \text{ kNm}$$

$$M_{8-9}^F = 78.8 + 49 \times 4 \times 0.16 = 110.2 \text{ kNm}$$

Solve for stiffnesses of beams 11–12 and 8–9 (Figure 5.17):

$$\begin{aligned} R &= M_A \left( \frac{1}{8000 \times 10^6} + \frac{8000}{2 \times 205 \times 10^3 \times 36\,200 \times 10^4} \right) / \\ &\quad \left( \frac{8000^2}{3 \times 205 \times 10^3 \times 36\,200 \times 10^4} + \frac{8000}{8000 \times 10^6} \right) \\ &= 1.39 \times 10^{-4} M_A \end{aligned}$$

$$M_B = M_A - 1.39 \times 10^{-4} M_A \times 8000 = -0.112 M_A$$

Solve equation for  $M_A$ :

$$\begin{aligned} 1.0 &= \frac{M_A}{J} + \frac{M_A l}{2EI} - \frac{0.112 M_A}{J} - \frac{0.112 M_A l}{2EI} \\ 1.0 &= \frac{0.888 M_A}{8000 \times 10^6} + \frac{0.888 \times 8000 M_A}{2 \times 205 \times 10^3 \times 36\,200 \times 10^4} \\ M_A &= 6.29 \times 10^9 \end{aligned}$$

In terms of  $I/I$  the stiffness for beam 11–12 is

$$\frac{6.29 \times 10^9}{4 \times 205 \times 10^3} = 7671$$

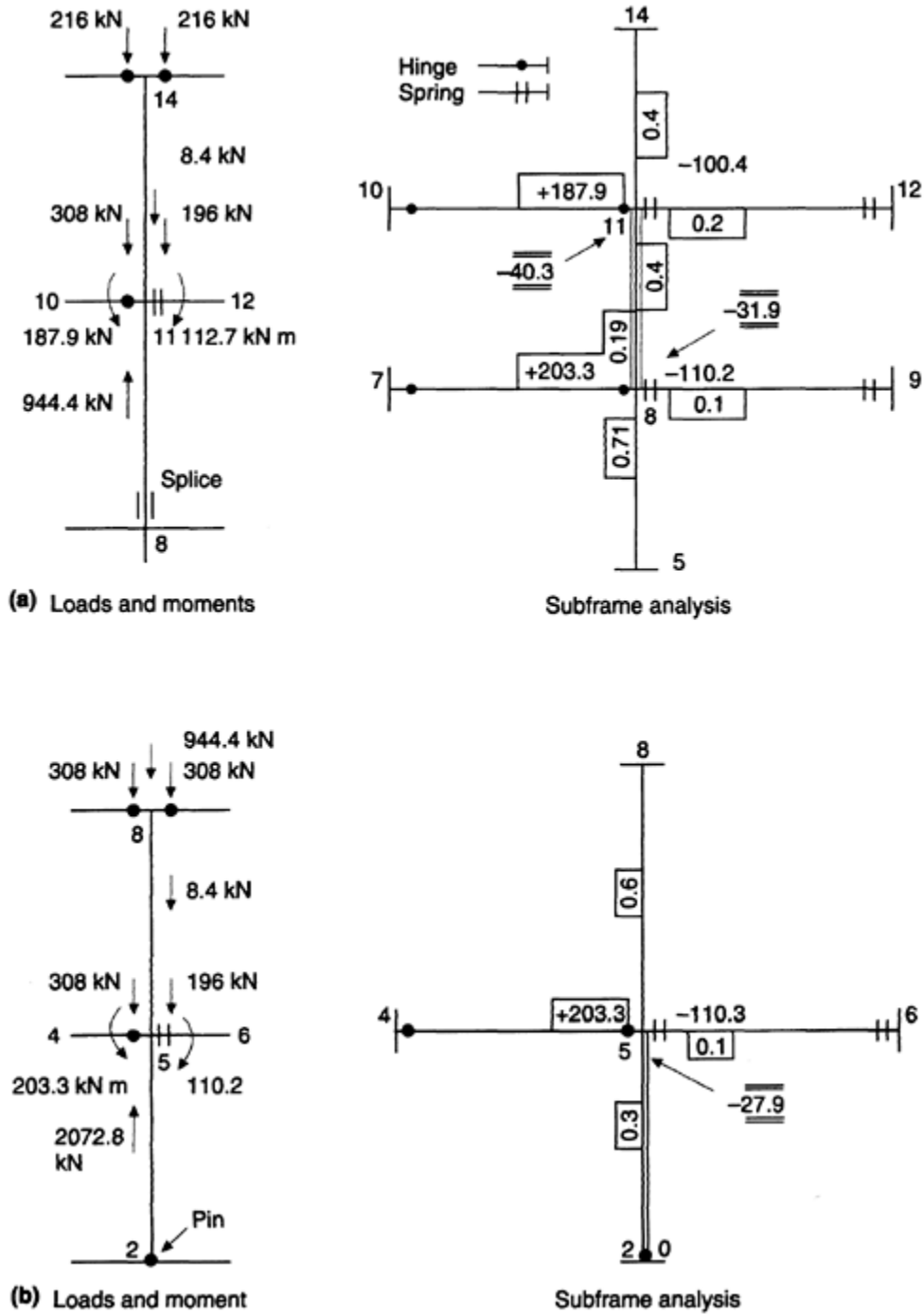

Fig. 5.17 Internal column design: (a) upper length 8–11–14; (b) lower length 2–5–8.

The subframe for column analysis is shown in Figure 5.17(a). The assumed column sections and stiffnesses are:

- 8–11, 11–14—203×203 UC60,  $I/I = \frac{6090 \times 10^4}{22\,200 \times 10^4} \cdot \frac{4000}{4000} = 15225$
- 5–8—305×305 UC97,  $I/I = \frac{22\,200 \times 10^4}{4000} = 55500$

Distribution factors—Joint 11:

$$K_{11-14} : K_{11-12} : K_{11-8} = \frac{15\,225 : 7671 : 15\,225}{83\,121} = 0.4 : 0.2 : 0.4$$

Joint 8:



$$K_{8-11}:K_{8-9}:K_{8-5}=0.19:0.1:0.71$$

The moment distribution analysis is carried out. The moments and axial load for column 8–11 are

$$M_{11-8}=40.3 \text{ kNm} \qquad M_{8-11}=31.9 \text{ kNm} \qquad F_{11}=944.4 \text{ kN}$$

Try 203×203 UC 46 (Section 5.4.3(a)), with  $p_c=188 \text{ N/mm}^2$ ,  $A=58.8 \text{ cm}^2$ ,  $M_c=136.7 \text{ kNm}$ ,  $M_b=119.2 \text{ kNm}$ ,  $m=0.43$ .

$$\text{Local capacity check}=0.88 \qquad \text{Overall buckling check}=1.0$$

This is satisfactory.

(g)

Centre column—lower length 2–5–8

Loads and moments are shown in Figure 5.17(b). Assume 305×305 UC 97 the beam end moments including moment due to eccentricity are

$$M_{5-4}=203.3 \text{ kNm} \qquad M_{5-6}=110.2 \text{ kNm}$$

The subframe is shown in the figure. The stiffnesses allowing for the pin end 1 are

- for 5–2,  $I/L=0.75 \times 22200 \times 10^4 / 6000 = 27750$ ;
- for 5–8,  $I/L=22200 \times 10^4 / 4000 = 55500$ ;
- for 5–6,  $I/L=7671$  (section 5.6.4(f)).

Distribution factors:

$$K_{5-2}:K_{5-8}:K_{5-6} = \frac{27\,500:55\,500:7671}{90\,671} = 0.3:0.6:0.1$$

The moment distribution analyses is carried out. The moments and axial for column 2–5 are

$$M_{5-2}=27.9 \text{ kNm} \qquad F_{5-2}=2072.8 \text{ kN}$$

Try 305×305 UC 97 (Section 5.4.3(d)), with  $p_c=188.2 \text{ N/mm}^2$ ,  $A=123 \text{ cm}^2$ ,  $M_c=437.2 \text{ kNm}$ ,  $M_b=374.6 \text{ kNm}$ ,  $m=0.57$ ,  $T=15.4$  and  $p_y=275 \text{ N/mm}^2$ .

$$\text{Local capacity check}=0.68 \qquad \text{Overall buckling check}=0.94$$

A check shows that column length 5–8 is not as highly stressed as 5–2.

(h)

Joints

The joint arrangements for the external and internal columns are shown in Figure 5.18. Only the plastic beam end moment causes tension in the bolts. The eccentric moment is due to bolt shear.

Table 5.2 Comparison of building designs

Design	Beams		External Columns		Internal Column		Total Steel weight <sup>a</sup> (kN)
	Roof	Floors	Upper	Lower	Upper	Lower	
Braced simple	457×191 UB 74	533×210 UB 92	203×203 UC 46	254×254 UC 89	203×203 UC 46	254×254 UC 107	10031
Braced rigid elastic	457×191 UB 67	533×210 UB 82	203×203 UC 60	254×254 UC 89	203×203 UC 60	305×305 UC 118	10348
Braced rigid plastic	406×140 UB 46	457×152 UB 60	254×254 UC 89	305×305 UC 97	203×203 UC 60	305×305 UC 97	9273
Braced semirigid plastic	457×152 UB 60	457×152 UB 82	203×203 UC 60	254×254 UC 97	203×203 UC 46	305×305 UC 97	10047

<sup>a</sup>5% is added for connections for simple design, 10% for rigid design.

$$\text{Tension } T=154/2 \times 0.67=114.9 \text{ kN}$$

Provide oversize bolts, 24 mm dia., Grade 8.8, with tension capacity 159 kN, shear capacity 132 kN, holes 26 mm dia.

For the endplate, yield line analysis gives

$$2 \times 114.9 \times 45 \times 10^3 = (200+148) \times 265t^2/4$$

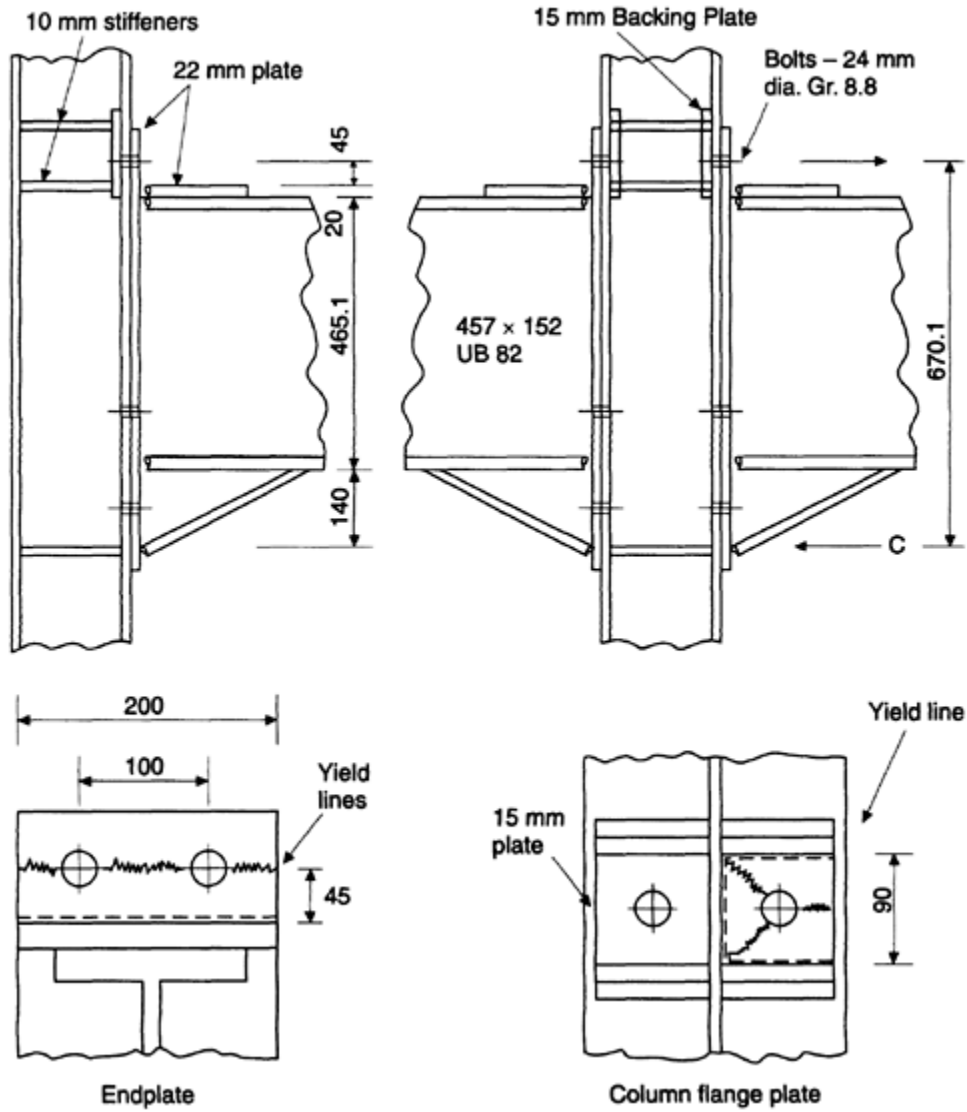

Fig. 5.18 Joint arrangement and detail.

Thus thickness  $t=21.2$  mm. Provide 22 mm plate.

The flange backing plate shown is designed to resist bolt tension. The yield line pattern is shown in the figure. Analysis gives

Yield line moment= $12100$  Nmm/mm

Thickness of plate required= $13.3$  mm

Provide 15 mm plate.

The joint is such as to cause only low stresses in the column flange.

5.7

SUMMARY OF DESIGNS

The various designs carried out are summarized in Table 5.2. The designs are remarkably similar in weight of steel required. The rigid plastic design is about 10% lighter than the rigid elastic design.

# CHAPTER 6

## Floor systems

### 6.1

#### FUNCTIONS OF FLOOR SYSTEMS

The floor system generally serves two purposes.

- Primarily the floor carries vertical dead and imposed load and transmits these loads through beams to the columns/walls.
- The floor also has to act as a horizontal diaphragm that ties the building together, stabilizes the walls and columns and transmits horizontal wind load to rigid frames, braced bays or shear walls.

The aims in design of the floor system are:

- to deliver the main vertical loads safely by the most direct and efficient route to the columns/walls without excessive deflection or vibration;
- to have the necessary horizontal strength/rigidity;
- to achieve a uniform arrangement and spacing of beams where possible to reduce costs—alternative layouts may need investigation;
- to keep construction depth to the minimum while accommodating necessary services—this reduces overall building costs;
- for all components to have adequate resistance to or protection against fire.

Types of floor systems are described below.

### 6.2

#### LAYOUTS AND FRAMING SYSTEMS

The layout of the floor framing depends on the shape and structural system used for the building. In steel-framed structures, the column arrangement defines the flooring divisions. Primary beams frame between the columns and may form part of the main vertical structural frames. Depending on spans, secondary beams may be provided to subdivide the intercolumn areas. Column spacings normally vary from 4 to 8 m in rectangular-shaped buildings but can be much greater. Secondary beams are normally spaced at 3 to 4 m centres.

Tall buildings generally have a central core and perimeter columns or tube-wall construction. The floor beams or girders frame between the core and outside wall. This arrangement allows maximum flexibility in the division of floor areas using lightweight partitions.

Some floor framing systems are shown in [Figure 6.1](#). These include buildings with:

- one-way normally transverse framing where
  - slab spans one way longitudinally,
  - secondary beams span between frames and slabs span transversely;
- two-way framing with two-way spanning slabs;
- square, circular and triangular floor areas with beams spanning out from the core.

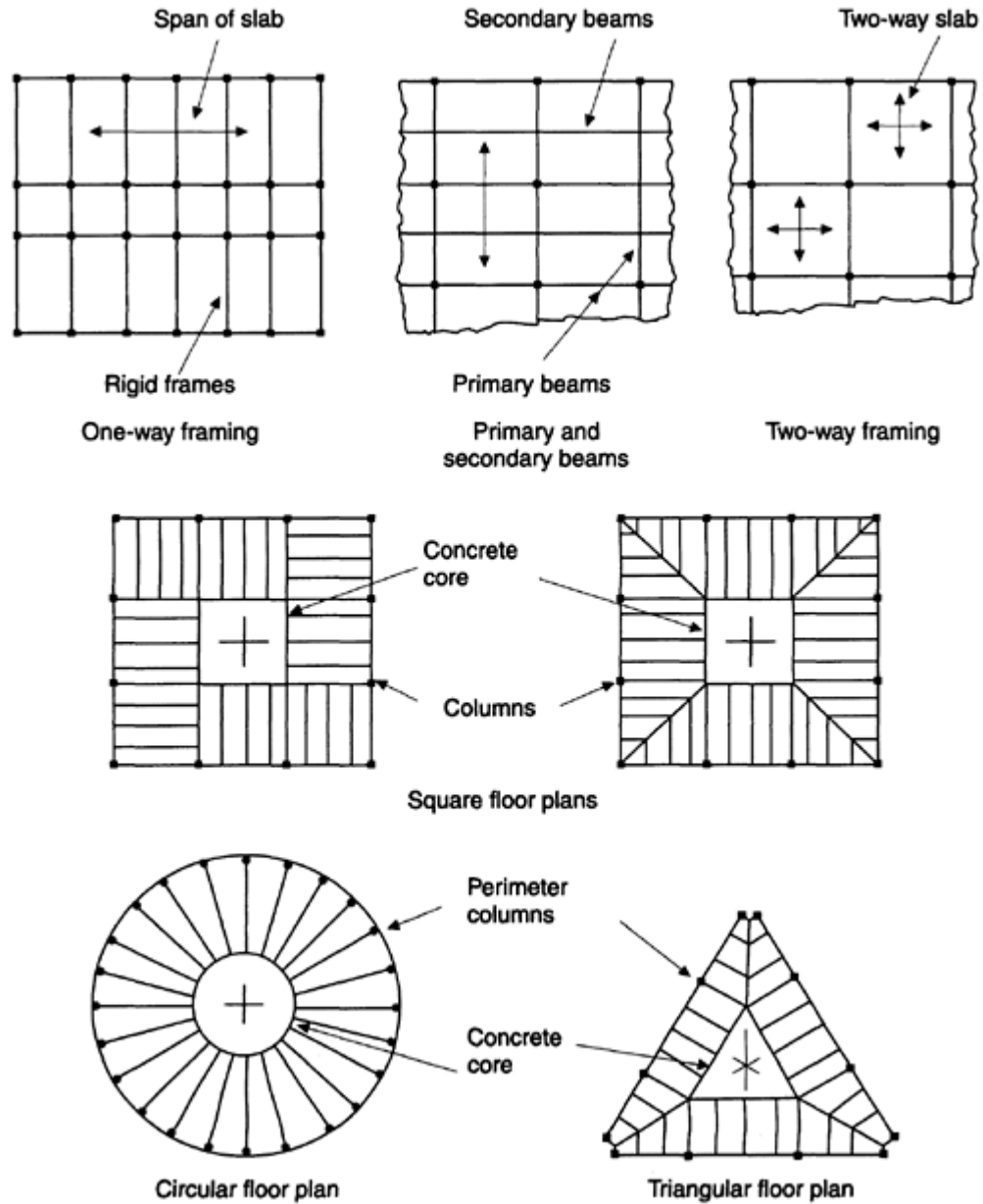

Fig. 6.1 Floor framing systems.

### 6.3

#### TYPES OF FLOOR CONSTRUCTION

Various types of floor construction in steel-framed buildings are shown in Figure 6.2. These can be classified as follows.

- Cast-*in-situ* concrete slabs, one- or two-way spanning, supported on steel beams or lattice girders. Ribbed or waffle slabs can also be used for long spans.
- Precast, prestressed concrete slabs, one-way spanning, supported on steel beams. Slabs can be solid or hollow or double-T in form. Units can also be supported on shelf angles to reduce floor depth as shown in Figure 6.2.
- Composite deck, where the slab is poured on profiled steel sheeting which is embossed with ribs to ensure composite action. Design where the steel decking acts only as permanent formwork can also be made.
- Cast-*in-situ* slab or composite concrete deck made to act compositely by stud shear connectors with the steel floor beams. This system gives considerable savings in weight of floor steel.

Lattice girders or castellated beams are more economical than universal beams for long spans. Lattice girder construction also permits services such as air conditioning ducts to be run through the open web spaces.

The stub girder floor is a special development aimed at giving long-span, column-free floor spaces. The system is only economical for long spans of 10–15 m. The construction gives up to 25% saving in weight of floor steel, a reduction in depth of floor and provides openings for services. Structurally, the stub girder acts like a modified form of composite Vierendeel girder. The validity of the system has been proved by extensive research and testing.

## 6.4 COMPOSITE FLOOR SLABS

### 6.4.1 General comments

The composite floor is cast on profiled steel sheets which act as permanent shuttering, supporting the wet concrete, reinforcement and construction loads. After hardening, the concrete and steel sheeting act compositely in carrying the loads.

Mesh reinforcement is provided over the whole slab. It is required to resist hogging moments. Alternatively, the concrete may be designed to carry the final loads without composite action when the sheeting acts as shuttering only.

Composite flooring is designed to BS 5950: Part 4. Decking manufacturers load/span tables can be used to select the slab and sheeting for a given floor arrangement (John Lysaght, n.d.; Precision Metal Flooring, 1993). For example, Precision Metal Flooring (1993) gives the maximum span, slab thickness and metal decking gauge for single- and double-spanning slabs and propped slabs for various values of imposed load. The tables are based on:

- construction load 1.5 kN/m<sup>2</sup>;
- deflection  $\geq$  span/180 (construction), span/350 (composite slabs);
- decking Grade Z 28 yield strength 280 N/mm<sup>2</sup>.
- concrete Grade 30;
- mesh to BS 5950: Part 4;
- shear connection—embossing and deck shape.

Fire load/span tables are also given to select slab thicknesses for various imposed loads and fire rating times.

### 6.4.2 Design procedure

The design procedure from BS 5950: Part 4 is set out briefly as follows.

(a) Decking strength and serviceability. This depends on:

- effective section of compression flange and web—these are reduced due to buckling;
- support capacity;
- web strength;
- deflection limit.

Design is to be in accordance with BS 5950: Part 6.

(b) Composite deck. Strength and serviceability checks are made to include:

- moment capacity for sagging moments at mid-span and hogging moments over supports;
- shear-bond capacity—some factors in the code expression must be obtained by tests on given decking;
- vertical shear capacity;
- deflection of the composite slab.

Expressions are given for simply supported and continuous slabs.

A composite deck section and sections for sagging and hogging moments are shown in [Figure 6.3](#).

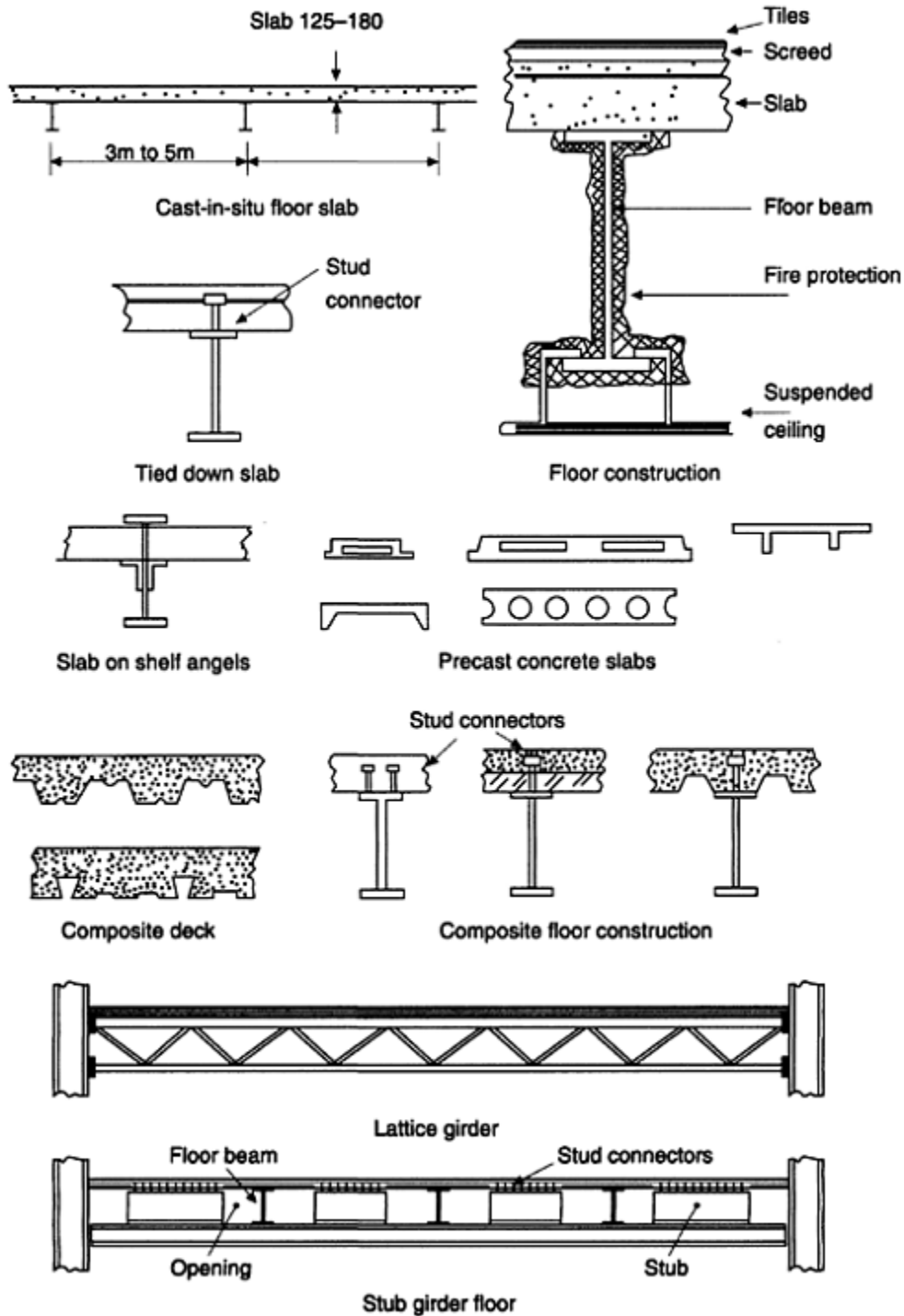

Fig. 6.2 Types of floor construction.

6.5  
COMPOSITE BEAM DESIGN

6.5.1  
Design basis

Design of composite beams is to conform to BS 5950: Part 3.

The composite beam is formed by connecting the concrete slab. The commonly used connector is the headed stud. The slab is to be a reinforced concrete floor slab or a slab supported on profiled steel sheeting.

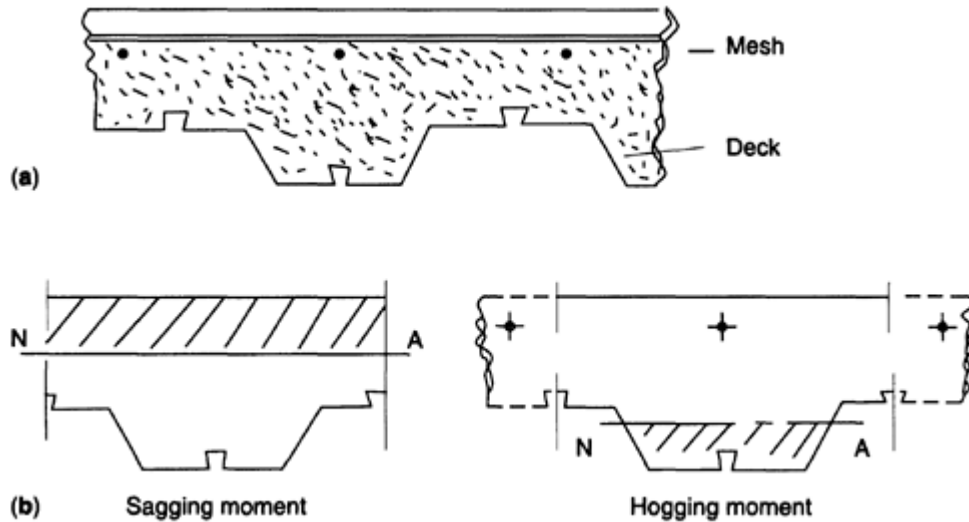

Fig. 6.3 Floor sections: (a) composite deck; (b) moments in slabs.

The design process is outlined briefly. Detailed application of the code clauses is shown in the examples following.

### 6.5.2 Effective section

Referring to Clause 4.4.1 and Section 4.6 of the code and to Figure 6.4, the effective section for calculating moment capacity depends on the following.

#### (a) Effective breadth of slab

This depends on the direction of the slab span, whether perpendicular or parallel to the beam. For example, for a slab spanning perpendicular to the beam the total effective breadth  $B_e$  is the sum of effective breadths  $b_e$  on each side:

$$b_e = L_z / 8 \quad \text{➤ half the distance to the adjacent beam}$$

where  $L_z$  is the distance between points of zero moment, equal to the span of a simply supported beam.

Detailed provisions are given for other cases.

#### (b) Composite slab

For a slab spanning perpendicular to the beam, neglect ribs—use only concrete above ribs. For a slab spanning parallel to the beam—use full concrete section.

#### (c) Portions neglected on the effective section

Neglect concrete in tension, the profiled sheets in a composite slab and nominal mesh or bars less than 10 mm diameter.

### 6.5.3 Plastic moment capacity

The moment capacity of a composite section is based on (Clause 4.4.2):

- concrete stress in compression =  $0.45 f_{cu}$ , where  $f_{cu}$  is the concrete grade;
- reinforcement in tension =  $0.87 f_y$ , where  $f_y$  is the characteristic strength.

Only plastic and compact universal beam sections are considered.

#### **6.5.4 Construction**

The weight of wet concrete and construction loads is carried by the steel beam. For both propped and unpropped construction, beams may be designed assuming that at the ultimate limit state, the whole load acts on the composite member (Clause 5.1).

#### **6.5.5 Continuous beam analysis**

See [Section 5.2](#) of the code, on which the analysis may be based.

##### *(a) Elastic analysis and redistribution*

The analysis is based on the value of the gross second moment of area of the uncracked section at mid-span ([Figure 6.4\(e\)](#)). Concrete in the ribs may be neglected (Clause 5.2.3 of the code).

[Section 4.1](#) of the code gives an expression for calculating the effective modular ratio  $\alpha_e$  for the concrete. This depends on the proportion of the total load that is long term.

The imposed load is to be arranged in the most unfavourable realistic pattern. The patterns to be investigated are

- Alternate spans loaded;
- Two adjacent spans loaded.

Dead load factors need not be varied. The resulting negative moment may be reduced by an amount not exceeding values given in Table 4 in the code. For plastic sections, 40% redistribution is permitted.

##### *(b) Simplified method*

The moment coefficients from Table 3 of the code can be used for uniform beams with uniformly distributed loads. Detailed requirements are given in Clause 5.2.2.

##### *(c) Plastic Analysis (Clause 5.2.4)*

This may be used for uniform beams with uniform distributed load.

#### **6.5.6 Design of members**

##### *(a) Vertical shear (Clause 5.3.4)*

The vertical shear must be resisted by steel beam web. The moment capacity is reduced by high shear load.

##### *(b) Positive moment (Clause 5.3.1)*

The moment capacity is the plastic moment capacity of the composite section.



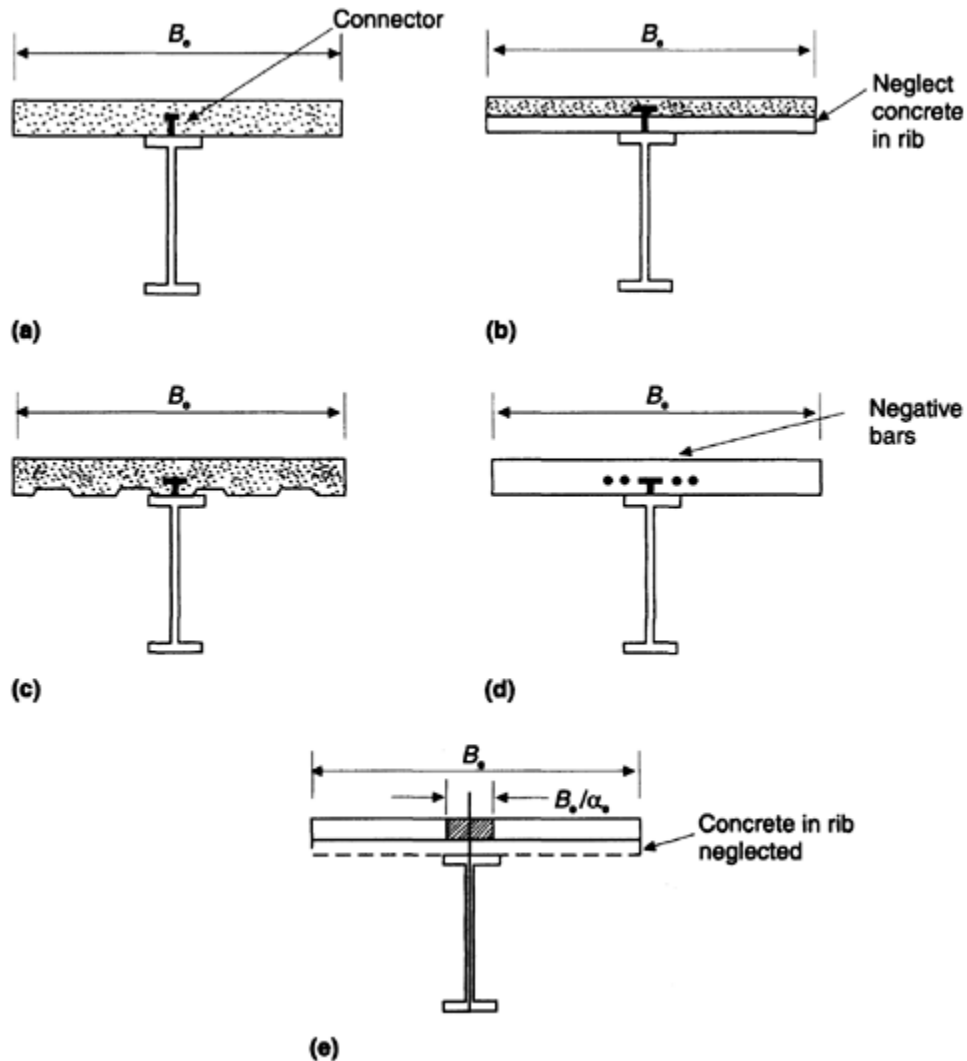

**Fig. 6.4** Effective section: (a) plain slab; (b) sheet perpendicular to beam; (c) sheet parallel to beam; (d) negative moment; (e) transformed section.

(c)  
Negative moment (Clauses 5.3.2 and 5.3.3)

The moment capacity is based on the steel section and effectively anchored tension reinforcement within the effective breadth of the concrete flange.

(d)  
Stability of the bottom flange (Clause 5.2.5)

In continuous beams the stability of the bottom flange requires checking at supports for each span. Provisions for making the check are given in the clause. Lateral supports may be required. The unsupported length may be taken as the distance from the support to the point of contraflexure.

### 6.5.7 Shear connectors (Section 5.4 of code)

The shear connector must transmit the longitudinal shear between the concrete slab and steel beam without crushing the concrete and without excessive slib or separation between the slab and beam. Headed studs welded to the beam are the main type of connector used.

(a)

*Connector capacity*

In a solid slab the capacity of a connector is:

- positive moments,  $Q_p=0.8 Q_k$ ;
- negative moments,  $Q_n=0.6 Q_k$ .

$Q_k$  is the characteristic resistance of a connector from Table 5 in the code, e.g. for a 19 mm stud 100 mm high in Grade 30 concrete,  $Q_k=100$  kN.

(b)

*Number of connectors required*

For positive moments the number  $N_p=F_p/Q_p$ , where  $F_p$  is the compressive force in the concrete at the point of maximum positive moment.

For negative moments, the number  $N_n=F_n/Q_n$ , where  $F_n$  is the force in the tension reinforcement.

The total number of connectors between the point of maximum moment and the support is  $N_p+N_n$  connectors should be spaced uniformly. The minimum spacing is five times the stud diameter.

(c)

*Characteristic resistance of headed studs*

Resistance values for solid slabs are given in Table 5 in the code. Formulas are given for modifying these values when profiled sheets are used.

**6.5.8****Longitudinal shear (Section 5.6 of code)**

Transverse reinforcement runs perpendicular to the beam span. Longitudinal shear from the connectors is resisted by the concrete flange, the transverse reinforcement and the steel sheeting if used.

(a)

*Longitudinal shear*

The longitudinal shear force per unit length is

$$v=NQ/S$$

where  $N$  is number of connectors per unit length,  $S$  is unit length and  $Q$  is  $Q_p$  or  $Q_n$  (section 6.5.7).

(b)

*Shear resistance*

An expression is given in the code for calculating the shear resistance per shear surface for normal and lightweight concrete. This includes contributions from the transverse reinforcement, the concrete slab and the profiled sheet if used. The formula and its application are described in the examples following sections 6.6 and 6.7.

(c)

*Shear surfaces*

Transverse shear surfaces for a solid slab and slab on profiled sheets are shown in Figures 6.5 (section 6.6.2) and 6.15 (section 6.7.6).

(d)

*Profiled sheeting*

Clause 5.6.4 sets out the method of calculating the contribution of the profiled steel sheeting (section 6.7.6).

### 6.5.9 Deflection (Section 6 of code)

#### (a) Construction

In unpropped construction:

- steel beam carries concrete slab and beam;
- composite section carries the imposed loads.

In propped construction, the composite section carries all loads. The behaviour is taken as linear elastic.

#### (b) Simply supported beams

Calculate deflection using the properties of the gross uncracked section ([section 6.5.5](#) (a) above).

#### (c) Continuous beams

Allowances are to be made for:

- Pattern loading—determine moments due to unfactored imposed load, on all spans then reduce support moments by 30%;
- shakedown—described in the code.

Clause 6.1.3.5 of the code gives an expression for calculating the mid-span deflection  $\delta_c$  for a continuous beam under uniform load or symmetrical point loads. In this expression, the simply supported beam deflection is modified according to the values of the span support moments as modified as noted above. (An example is given in [section 6.7.7](#) below).

## 6.6 SIMPLY SUPPORTED COMPOSITE BEAM

### 6.6.1 Specification

Consider the simply supported steel floor beam in the structure shown in [Figure 5.1](#). The characteristic loads on the beam are:

- dead load—
  - slab and steel beam—23 kN/m;
  - tiles, screed, partitions, ceiling, services—12 kN/m;
- imposed load—(3.5 kN/m<sup>2</sup>)—17.5 kN/m.

The design load on the composite section is 77 kN/m, and

$$M = 77 \times 8^2 / 8 = 616 \text{ kN/m}$$

The materials are:

- concrete, with  $f_{cu} = 30 \text{ N/mm}^2$ ;
- steel, with  $p_y = 275 \text{ N/mm}^2$ .

The slab is 180 mm thick and the steel beam is 533×210 UB 92 with no composite action; the span is 8 m.

Redesign the beam as a composite section.

## 6.6.2

**Moment capacity (Section 4.4 of code)**

Concrete flange breadth:

$$B_e = \text{Span}/4 = 2 \text{ m}$$

Try 457×152 UB 52, with  $A=66.5 \text{ mm}^2$ ,  $D=449.8 \text{ mm}$ ,  $t=7.6 \text{ mm}$ ,  $I=21300 \text{ mm}^4$ . The composite section is shown in Figure 6.5.

Assuming the neutral axis lies in the slab, the depth is

$$x = \frac{275 \times 66.5 \times 10^2 / (0.45 \times 30 \times 2000)}{275 \times 66.5 / (0.45 \times 30 \times 2000) + 21300 / (449.8/2)^2} = 67.7 \text{ mm}$$

$$\text{Lever arm } Z = 180 - (67.7/2) + (449.8/2) = 371.1 \text{ mm}$$

$$\text{Moment capacity } M_p = 275 \times 66.5 \times 10^2 \times 371.1 / 10^6 = 678.6 \text{ kNm} > \text{applied moment} = 616 \text{ kNm}$$

The section is satisfactory for moment.

## 6.6.3

**Shear (Section 5.3.4 of code)**

The shear capacity is

$$P_v = 0.5 \times 275 \times 449.8 \times 7.6 / 10^3 = 470 \text{ kN}$$

$$> \text{applied shear} = 308 \text{ kN}$$

This is satisfactory.

## 6.6.4

**Shear connectors (Section 5.4 of code)**

Provide headed studs 19 mm dia. × 100 mm high, with characteristic resistance  $Q_k=100 \text{ kN}$ . The capacity in a solid slab under positive moment is

$$Q_p = 0.8 \times 100 = 80 \text{ kN}$$

The number of connectors each side of the centre of the beam is

$$N_p = (275 \times 66.5) / (80 \times 10) = 23$$

$$\text{Spacing in pairs} = 4000 \times 2 / 22 = 364 \text{ (say 300 mm)}$$

## 6.6.5

**Longitudinal shear**

The surfaces subjected to longitudinal shear from the connectors and the slab reinforcements are shown in Figures 6.4 and 6.5 (b). The top bars reinforce the slab for hogging moment. The bottom 10 mm dia. bars at 180 mm centres,  $A_{sv}=436 \text{ mm}^2/\text{m}$ , resist shear due to composite action (Section 5.3.1 of code).

The longitudinal shear is

$$v = 2 \times 1000 \times 80 / 300 = 533.3 \text{ kN/m}$$

The flange resistance (Clause 5.6.3), where the length of shear surface a-a is 340 mm approx. and of shear surface b-b is  $2 \times 180 \text{ mm}$ , is given by

$$V_r = [(0.7 \times 436 \times 460 \times 2) + (0.03 \times 340 \times 1000 \times 30)] / 10^3 = 586 \text{ kN/m}$$

This is satisfactory.

## 6.6.6

**Deflection (Section 6.1 of code)**

The beam is to be unproped. The deflection of the steel beam due to self-weight and slab (23 kN/m) is

$$\delta_D = \frac{5 \times 23 \times 8000^4}{384 \times 205 \times 10^3 \times 21 \ 300 \times 10^4} = 28.1 \text{ mm}$$

$$= \text{Span}/285$$

The composite section carries the imposed load plus finishes and partitions, total 29.5 kN/m. The deflection is calculated using the properties of the gross uncracked section.

The modular ratio  $\alpha_e$  is determined using Clause 4.1. The imposed load is one-third long term. The proportion of the total loading which is long term is

$$P_e = (52.5 - 17.5/3) / 52.5 = 0.89$$

$$\alpha_e = 6 + (0.89 \times 12) = 16.7$$

The transformed section is shown in Figure 6.5 (c). Locate the neutral axis

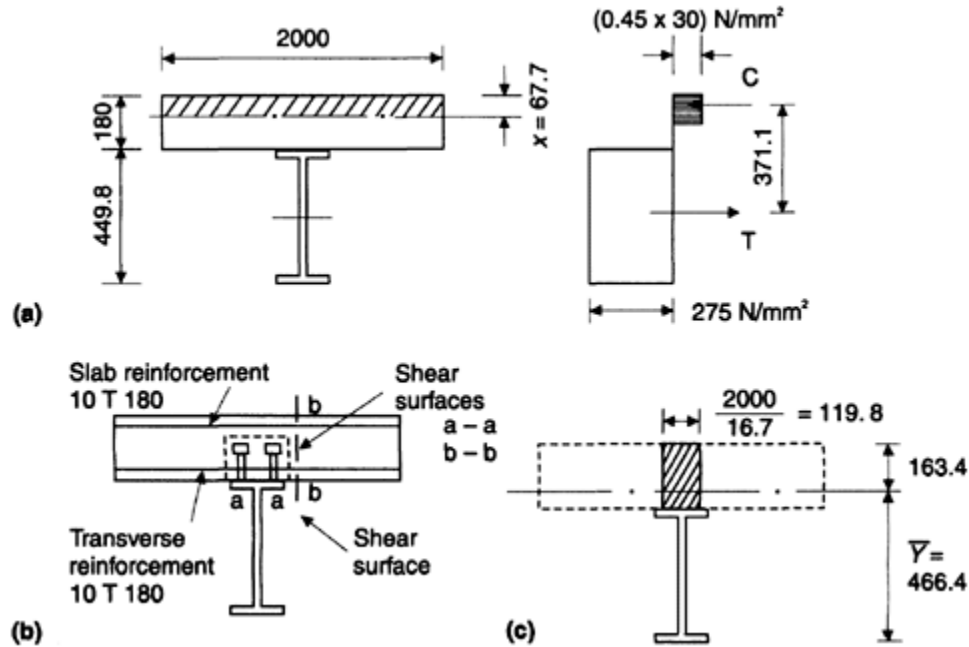

Fig. 6.5 Composite beam: (a) moment capacity; (b) longitudinal shear; (c) transformed section.

$$\bar{y} = \frac{(66.5 \times 10^2 \times 224.9) + (180 \times 119.8 \times 539.8)}{(66.5 \times 10^2) + (180 \times 119.8)} = 466.4 \text{ mm}$$

$$I_G = (21300 \times 10^4) + (6650 \times 241.5^2) + (119.8 \times 180^3 / 12) + (180 \times 119.5 \times 73.4^2) = 7.75 \times 10^8 \text{ mm}^4$$

The deflection of the composite section is

$$\begin{aligned} \delta &= \frac{5 \times 17.5 \times 8000^4}{384 \times 205 \times 10^3 \times 7.75 \times 10^8} = 5.84 \text{ mm} \\ &= \text{Span}/1369 \\ &< \text{Span}/360 \end{aligned}$$

This is satisfactory.

## 6.7 CONTINUOUS COMPOSITE BEAM

### 6.7.1 Specification

#### (a) Building

A two-storey building and part floor plan for the first floor is shown in Figure 6.6. Design the end span of the continuous three-span floor beam ABCD. The beam is continuous over the ground floor columns. The loads are given below.

#### (b) Flooring

The floor construction is PMF Com Floor 70. This is double-spanning, unpropped, span 3m, 1.2 mm gauge decking with normal weight concrete. The decking is shown in Figure 6.7. From the manufacturer's load/ span tables (Precision Metal Forming, 1993), for imposed loading of 6.7 kN/m<sup>2</sup>, the maximum permitted span for a slab thickness of 150 mm is 3.39 m. The required span is 3 m. The fire load/span tables give a permitted span of 3.68 m for 90 m in fire rating, which is satisfactory. The imposed load on the slab including ceiling, finishes etc. is given below. The slab dead load is 3.1 kN/m<sup>2</sup>.

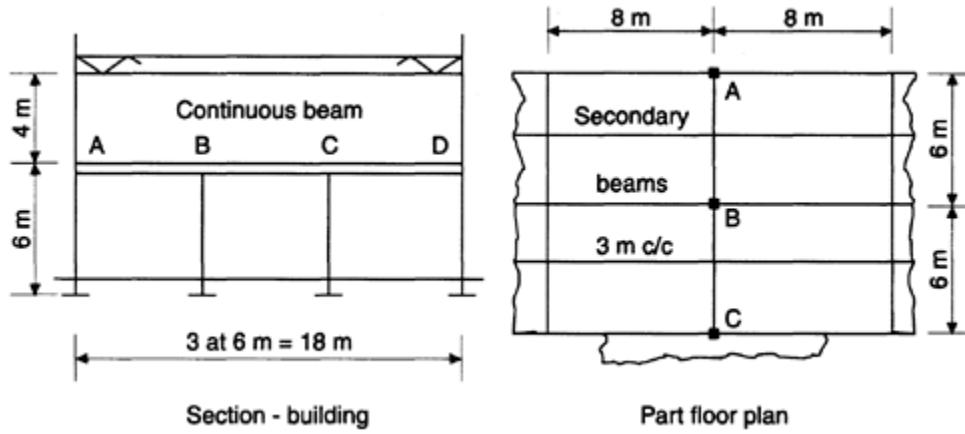

Fig. 6.6 Two-storey building: (a) section; (b) part floor plan.

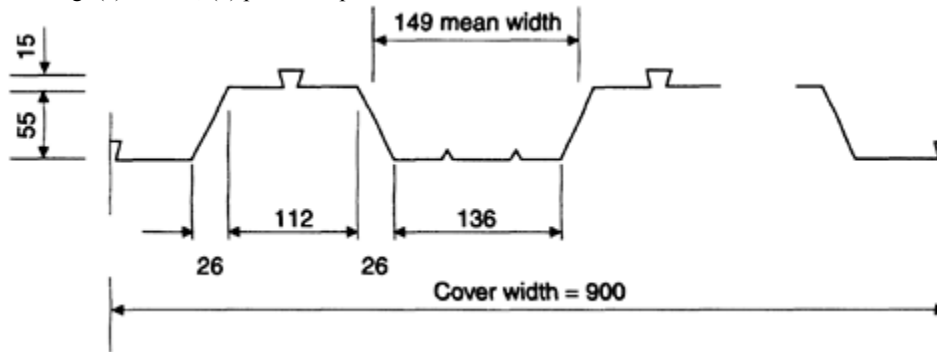

Fig. 6.7 Com Floor 70 decking.

### 6.7.2 Floor loads

(a)  
Separate characteristic loads

**(i) During construction (Figure 6.9(a), Section 6.73)**

The dead load of the slab, deck and secondary beam is 3.2 kN/m, thus

$$\text{Point load at E} = 3.2 \times 8 \times 3 = 76.8 \text{ kN}$$

The dead load of the continuous beam and base is 0.5 kN/m<sup>2</sup>.

The imposed load (Clause 2.2.3) is 0.5 kN/m<sup>2</sup>, thus

$$\text{Point load at E} = 0.5 \times 8 \times 3 = 12 \text{ kN}$$

The design loads are

$$\text{Point load} = (76.8 \times 1.4) + (12 \times 1.6) = 126.7 \text{ kN}$$

$$\text{Distributed load} = 1.4 \times 0.5 = 0.7 \text{ kN/m}$$

**(ii) Dead load on composite beam**

The distributed load is 2.7 kN/m<sup>2</sup> (finish 1 kN/m<sup>2</sup>, ceiling 0.5 kN/m<sup>2</sup>, services 0.2 kN/m<sup>2</sup>, partitions 1 kN/m<sup>2</sup>), thus

$$\text{Point load at E} = 2.7 \times 8 \times 3 = 64.8 \text{ kN}$$

The uniform load for beam and protection is 1.5 kN/m.

**(iii) Imposed load carried by composite beam**

The imposed load is 3.5 kN/m<sup>2</sup> (Figure 6.8 (c)), thus

$$\text{Point load at E} = 3.5 \times 8 \times 3 = 84 \text{ kN}$$

(b)

*Check imposed load on decking*

$$\text{Imposed floor load}(3.5 \text{ kN/m}^2) + \text{Finish}(1 \text{ kN/m}^2) + \text{Ceiling and services}(0.7 \text{ kN/m}^2) + \text{Partitions}(1 \text{ kN/m}^2) = 6.2 \text{ kN/m}^2 < 6.7 \text{ kN/m}^2$$

(c)

*Design loads on the composite beam***(i) Dead load—permanent loads**

$$\text{Point load} = (76.8 + 64.8)1.4 = 198.2 \text{ kN}$$

$$\text{Distributed load} = 1.5 \times 1.6 \times 6 = 14.4 \text{ kN/Span}$$

The dead load factor is not varied.

**(ii) Imposed load**

This is arranged to give maximum moments.

$$\text{Point load} = 84 \times 1.6 = 134.4 \text{ kN}$$

The design loads are shown in Figure 6.8(b)–(d) (section 6.7.3).

**6.7.3****Elastic analysis and redistribution**

Elastic analyses are carried out for the end span AB under pattern loading. A redistribution of 30% of the peak support moment is then carried out. (Table 4 in the code).

(a)

*Approximate size of steel beam*

Design one 6 m span as a simply supported beam. Neglect the self-weight.

$$M = (198.2 + 134.4)6/4 = 498.9 \text{ kNm}$$

$$S = 498.9 \times 10^3 / 275 = 1814 \text{ cm}^3$$

Reducing by say, 40% gives  $S = 1088 \text{ cm}^3$ . Try 457 × 152 UB 52, with  $S = 1090 \text{ cm}^3$ .

(b)

*Distribution factors***(i) Effective modular ratio (Clause 4.1)**

$$\alpha_e = \alpha_s + P_1(\alpha_l - \alpha_s) \quad \alpha_l = \text{long-term modulus} = 18 \quad \alpha_s = \text{short-term modulus} = 6 \quad P_1 = \text{portion of total load which is long term (section 6.7.2(b))} = (9.4 - (3.5/3))/9.4 = 0.88$$

$$\alpha_e = 6 + 0.88(18 - 6) = 16.6$$

**(ii) Second moment of area  $I_G$** 

Use the gross uncracked for the elastic global analysis (Clause 5.2.3). For the gross value of  $I_G$  use the mid-span effective breadth uncracked, but neglect concrete in the ribs (Clause 4.2.2).

The effective breadth of concrete flange (Section 4.6 and Figure 2 of code) is:

- for span AB,

$$B_e = 0.8 \times 6000 / 4 = 1200 \text{ mm}$$

- for span BC,

$$B_e = 0.7 \times 6000 / 4 = 1050 \text{ mm}$$

The gross and transformed sections are shown in Figure 6.8 for span AB.

For the steel beam of 457 × 152 UB 52,  $A = 66.5 \text{ cm}^2$ ,  $I_X = 21300 \text{ cm}^4$  (dimensions on Figure 6.8).

For the transformed concrete,  $A = 68.7 \text{ cm}^2$ ,  $I_X = 517 \text{ cm}^4$ .

The neutral axis is

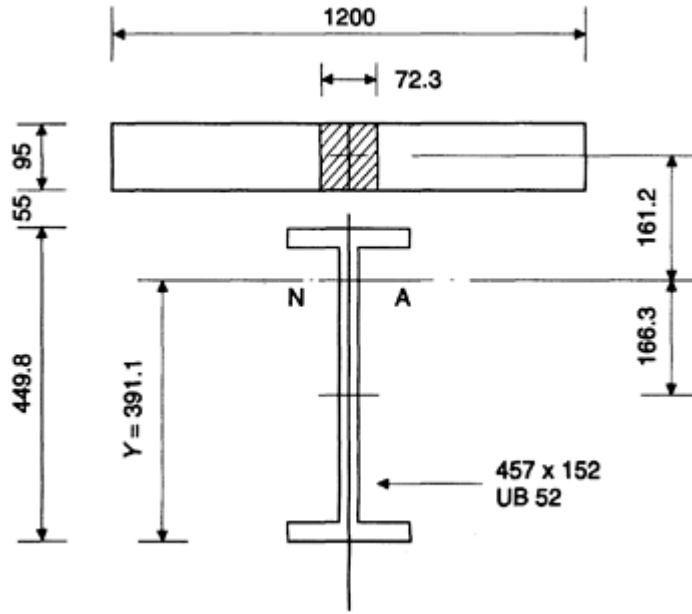

Fig. 6.8 Span AB—section.

$$\bar{y} = \frac{(66.5 \times 22.5) + (68.7 \times 55.2)}{66.5 + 68.7} = 39.11 \text{ cm}$$

For span AB,

$$I_G = (66.5 \times 16.63^2) + 21300 + (68.7 \times 16.12^2) + 517 = 58060 \text{ cm}^4$$

For span BC,

$$I_G = 56309 \text{ cm}^4$$

**(iii) Distribution factors**

$$K_{BA} : K_{BC} = \frac{(58\ 060/600) : (56\ 309/600)}{96.8 + 93.8} = 0.51 : 0.49$$

The analysis should be based on the assumption of a uniform glass uncracked beam.

(c)  
*Elastic analysis*

The moment coefficients from the *Steel Designers Manual* (1986) are used in the analysis. Analyses are performed for:

- construction loads on the steel beam;
- final loads on the composite beam (Clause 5.2.3.2, Pattern loads) for
  - dead load,
  - imposed load on spans AB, BC,
  - imposed loads on spans AB, CD.

The loads, moments and shears for the four load cases are shown in [Figure 6.9](#).

The maximum design actions for the end span for elastic analysis are:

- for steel beam—construction loads,

$$M_E = 135.2 \text{ kNm}$$

- for composite beam,

$$M_B = 187 + 141.1 = 328.1 \text{ kNm}$$

$$M_E = 214.5 + 173.4 = 387.9 \text{ kNm}$$

$$V_{BA} = 137.5 + 90.7 = 228.2 \text{ kN}$$



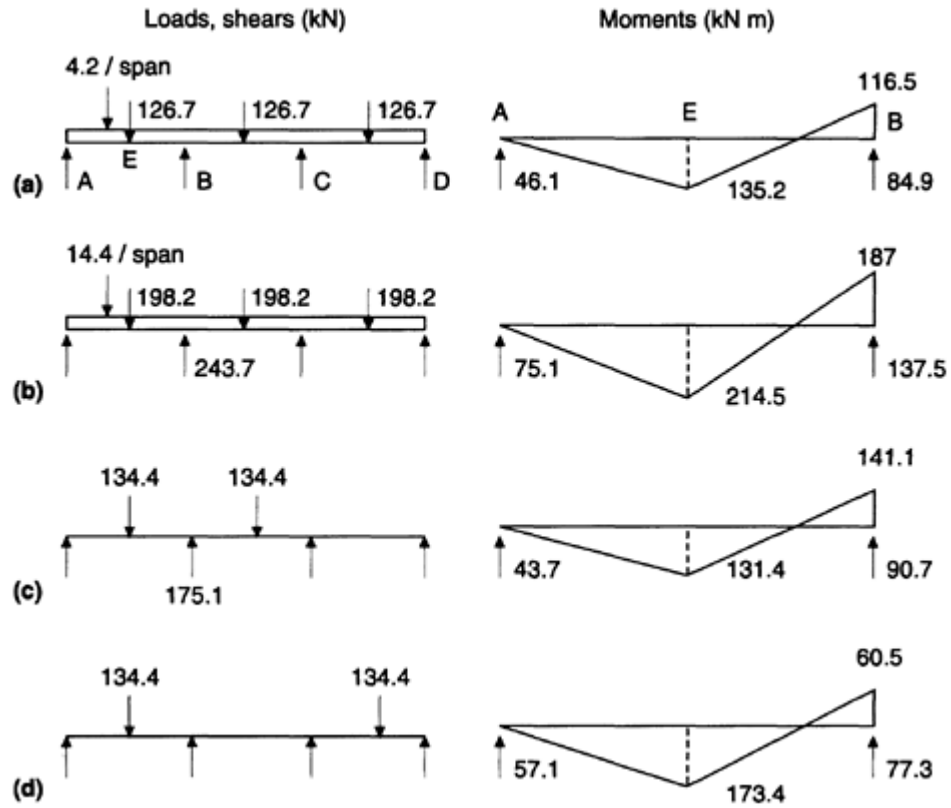

Fig. 6.9 Design actions for end span AB: (a) construction loads on steel beam; (b) permanent dead load on composite beam; (c) imposed load on spans AB, BC; (d) imposed load on spans AB, CD.

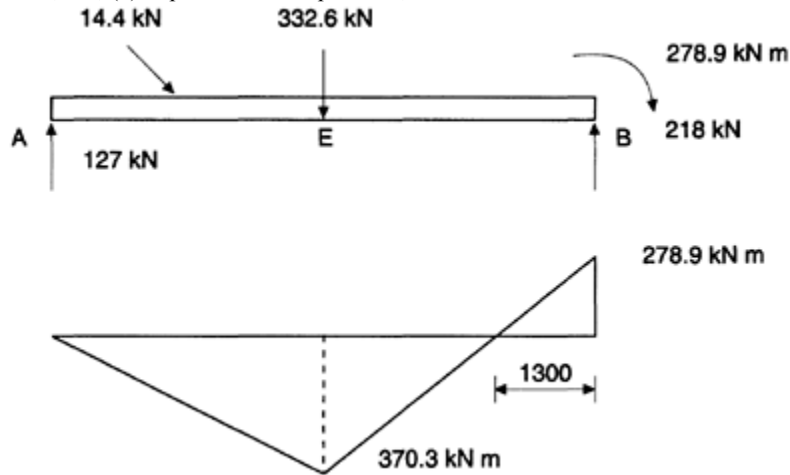

Fig. 6.10 Redistributed shears and moments.

(d)  
Redistribution

Reduce the peak support moment of  $-328.1$  kNm by 15% to give

$$M_B = -278.9 \text{ kNm}$$

$$\text{Sagging moment} = 395.1 \text{ kNm}$$

$$\text{Shear} = 211.7 \text{ kN}$$

$$\text{Unsupported length of compression flange} = 1.1 \text{ m}$$

The redistributed moment and shears are shown in Figure 6.10.

### 6.7.4 Section design checks

(a)

*Steel beam during construction*

Assume that the length of the bottom flange in compression from support B to the point of contraflexure is 2.5 m.

Try 457×152 UB 52, with  $S=1090\text{cm}^3$ ,  $r_y=3.11\text{ cm}$ ,  $x=43.9$ ,  $\lambda=80$ ,  $p_b=190\text{ kNm}$  (Table 19):

$$M_c=190\times 1090/10^3=207\text{ kNm}>135.2\text{ kNm}$$

(b)

*Composite beam—sagging moment (Clause 4.4.1)*

The sagging moment capacity of the composite beam at mid-span is based on:

- effective flange breadth  $B_e$ ;
- the full concrete area including the ribs where the ribs are parallel to the beam;
- the sheeting, concrete in tension and reinforcement in compression is neglected.

The plastic moment capacity is found using (Clause 4.4.2):

- concrete stress,  $0.45 f_{cu}$ , where the concrete grade  $f_{cu}=30\text{ N/mm}^2$ ;
- design strength of steel  $p_y=275\text{ N/mm}^2$ .

The composite beam section is shown in [Figure 6.11](#).

The trial steel beam is 457×152 UB 52, with  $A=66.5\text{cm}^2$ .

Check location of neutral axis. The concrete flange capacity ([Figure 6.7](#)) is given by

$$0.45\times 30[(1200\times 95)+(136+26)4\times 55]/10^3=1539+481=2020\text{ kN}$$

The steel beam capacity is

$$275\times 66.5/10=1829\text{ kN}$$

Try locating neutral axis in ribs. Assume that the neutral axis lies  $y_1$  below the top of the rib ([Figure 6.11](#)). The depth of rib in compression is

$$1539+4[0.47y^2+(188-0.94y)y]0.45\times 30/10^3=1829$$

$$y_1=31\text{ mm}$$

The portion of the rib in compression is shown in [Figure 6.11](#) (a). The area of four ribs is  $21500\text{ mm}^2$ , with centroid  $15.1\text{ mm}$  from top. The capacity is given by

$$0.45\times 30\times 21\ 500/10^3=290\text{ kN}$$

The forces and their lever arms with respect to the neutral axis are shown in [Figure 6.11](#) (b). The moment capacity is

$$M_c=(1539\times 0.078)+(290\times 0.016)+(1829\times 0.249)=580\text{ kNm} > \text{Sagging moment } 370.3\text{ kNm}$$

In (d) and (e) below, the stability of the bottom flange is considered and the moment capacity is recalculated.

(c)

*Composite beam—hogging moment (Clauses 4.4.1, and 4.4.2)*

The capacity is based on:

- neglecting the concrete in tension and the profiled sheets;
- including the stresses to design strength  $p_y$  and reinforcement in tension at design strength  $0.87 f_y$ , where  $f_y$  is its characteristic strength.

The trial steel beam is 457×152 UB 52, where  $S=1090\text{ cm}^3$ , giving capacity for design strength  $p_y$  as

$$M_c=275\times 1090/10^3=229.8\text{ kNm} > \text{Support moment } 278.9\text{ kNm}$$

The stability of the bottom flange requires investigation (Clause 5.2.5). The span is loaded with the factored dead load and the negative moment at the support is taken as  $M_c$ , the plastic design moment. This need not be taken as more than the elastic moment without redistribution, i.e.  $328.1\text{ kNm}$  from [section 6.7.3\(c\)](#).

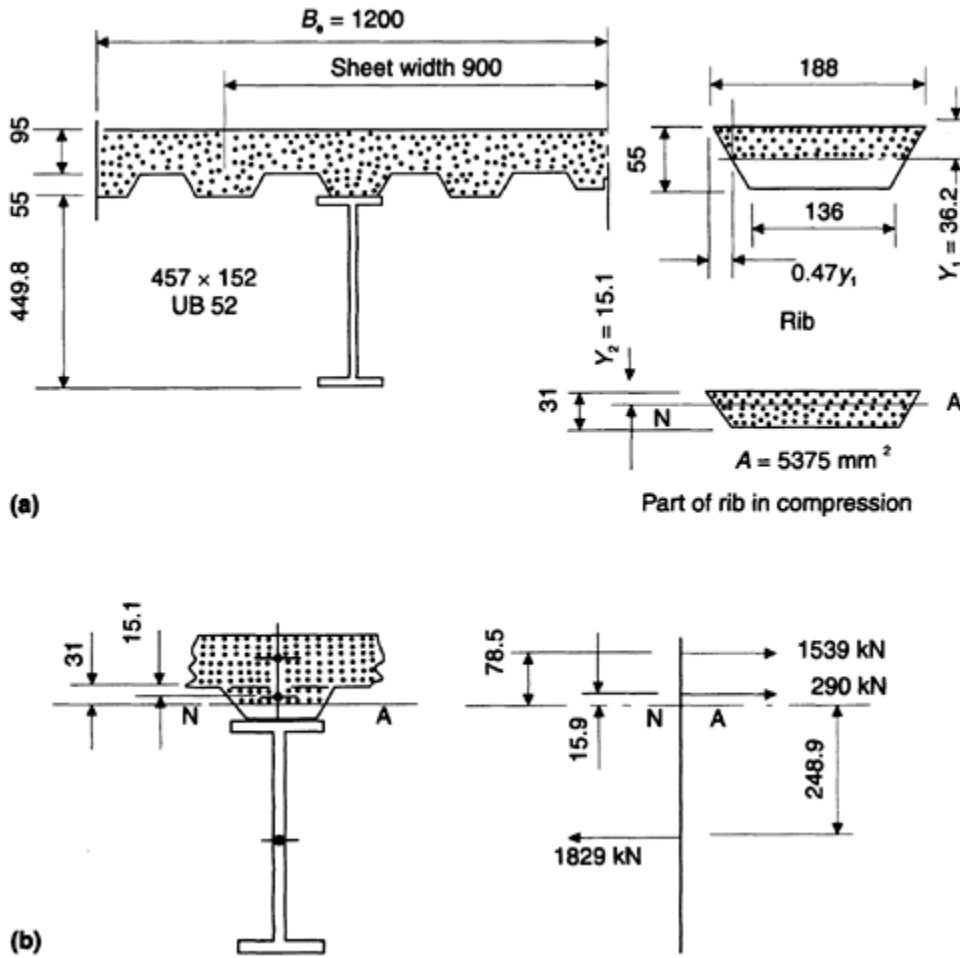

Fig. 6.11 Composite beam: (a) sagging section; (b) forces.

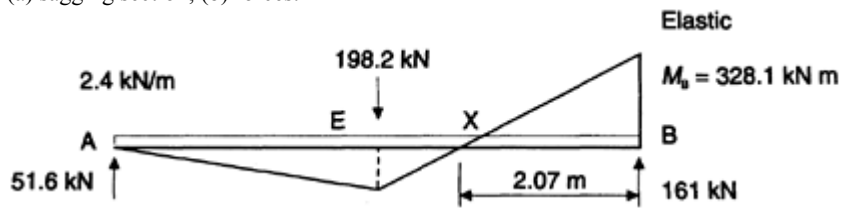

Fig. 6.12 End span—dead load and elastic moment.

The loads, reactions and moments for span AB are shown in Figure 6.12. Solve for distance  $XB=2.07$  m, the unsupported length of bottom flange in compression.

For 457×152 UB 52,  $r_y=3.11$  cm;  $u=0.859$ ;  $x=43.9$ ;  $\lambda=2070/31.1=66.5$ ;  $\lambda/x=1.51$ ;  $v=0.96$  (Table 4);  $\lambda_{LT}=uv \lambda=54.8$ ;  $p_b=226.5$  N/mm<sup>2</sup> (Table 11).

Capacity of the steel beam = 247 kNm < 278.9 kNm (redistribution moment) shown in Figure 6.10

The trial section is 457×152 UB 52 with four 16 mm dia. bars, Grade 460 (Figure 6.13). Assume that the neutral axis lies in the web:

$$(0.87 \times 460 \times 804) + (152 \times 10.9 \times 226.5) + (y \times 7.6 \times 226.5) = [(428 - y) 7.6 \times 226.5] + (152.4 \times 10.9 \times 226.5) \quad y = 120.6 \text{ mm}$$

The moment capacity is

$$M_c = (321.8 \times 0.241) + 376.3(0.126 + 0.313) + (207.6 \times 0.06) + (529.2 \times 0.154) = 336.8 \text{ kNm}$$

(f)  
Joint—beam to column

The joint arrangement is shown in Figure 6.14. This can be shown to be adequate.

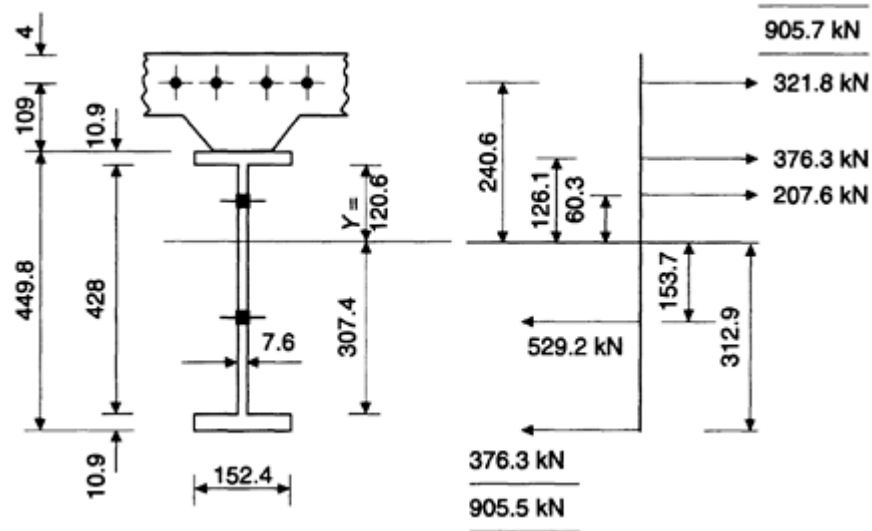

Fig. 6.13 Forces in composite section.

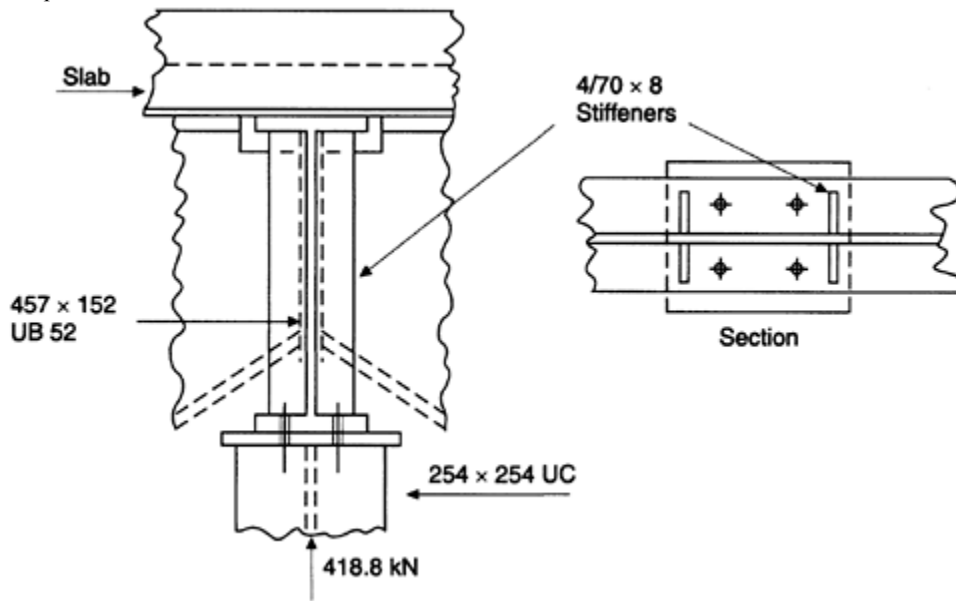

Fig. 6.14 Joint—beam to column.

(g)  
Beam shear

From Figure 6.9, the shear is

$$137.5 + 90.7 = 228.2 \text{ kN}$$

The shear is resisted by the web of the steel beam.

The shear capacity of 457×152 UB 52, with  $d/t=53.6$ , is

$$449.8 \times 7.6 \times 0.6 \times 275 / 10^3 = 564 \text{ kN}$$

This is satisfactory.

### 6.7.5 Shear connectors

Stud connectors 19 mm dia.×100 mm nominal height are to be provided. The characteristic load for Grade 30 concrete is  $Q_k=100$  kN per connector in a solid slab (Table 5 of code).

Referring to Clause 5.4.7.3, in slabs with ribs parallel to the beam where (Figure 5 in code)

Mean width of rib  $b_r=149$  mm

Overall depth of sheet  $D_p=55$  mm

$b_r/D_p=2.7>1.5(k=1)$

There is no reduction in the value of  $Q_k$ .

Referring to Clause 5.4.3, the capacity of shear connectors is

Positive moment  $Q_p=0.8 Q_k=80$  kN

Negative moment  $Q_n=0.6 Q_k=60$  kN

Referring to Clause 5.4.4.1, from Figure 6.11(b) the longitudinal force for positive moments is  $1539+290=1829$  kN.

Total number of connectors= $1829/80=23$

To develop the positive moment capacity, i.e. the number required each side of the point of maximum moment.

Referring to Clause 5.4.4.2, from Figure 6.12 the longitudinal force for negative moment is 321.8 kN.

Number of connectors= $321.8/60=6$  in span AB

Referring to Clause 5.4.5.1, the total number of connectors between a point of maximum positive moment and each support in span AB is  $23+23+6=52$ . Spacing the studs equally,

Spacing  $S=6000/52=115$  mm

Minimum spacing  $5d=95$  mm along beam.

## 6.7.6

### Longitudinal shear

The arrangement of the decking for positive and negative moments is shown in Figure 6.15. The mesh reinforcement for the slab is discussed below.

(a)

Positive moment (Clauses 5.6.1 and 5.6.2)

The sheeting and other transverse reinforcement can act as reinforcement to resist longitudinal shear from the shear connectors.

The longitudinal shear per unit length  $v$  at any point is determined by the connector spacing  $S$ :

$$v=NQ_p/S$$

where  $N$  is the number of connectors per unit length. Account is to be taken of the proportion of the effective breadth lying beyond the failure section in determining the shear at that section.

From Figure 6.15(a), the failure sections are aa and bb. For 1 m length:

$$N=1000/115=9 \text{ say, } Q_p=80 \text{ kN}$$

For section a-a:

$$v=9 \times 80=720 \text{ kN/m}$$

For section b-b:

$$v=720 \times 300/600=360 \text{ kN/m}$$

Referring to Clause 5.6.2, the resistance of the concrete flange for normal weight concrete is

$$u_r = 0.7A_{sv}f_y + 0.03A_{cv}f_{cu} + v_p$$

$$\leq 0.8A_{cv}\sqrt{f_{cu}} + v_p$$

where

$$f_{cu}=30 \text{ N/mm}^2$$

$$f_y=460 \text{ N/mm}^2$$

$A_{cv}$ =concrete area per unit length

$A_{sv}$ =area per unit length of reinforcement

$v_p$ =contribution of sheeting= $t_p p_{yp}$

$t_p$ =thickness of sheeting=1.2 mm

$p_{yp}=280 \text{ N/mm}^2$  (PMF Com Floor 70)

Try steel mesh A252—8 mm wires at 200 mm centres, with  $A_{sv}=252 \text{ mm}^2/\text{m}$ . This complies with Clause 25 of BS 5950: Part

4.

For section a-a, the resistance of two surfaces is

$$v_r=2[(0.7 \times 252 \times 460) + (0.03 \times 95 \times 1000 \times 30) + (1.2 \times 280 \times 1000)]/10^3 = 2(81.1 + 85.5 + 336) = 1005 \text{ kN/m}$$

$$\square 2 \times 0.8 \times 95 \times 10^3 \times 30^{0.5} / 10^3 = 832.5 \text{ kN/m} > 720 \text{ kN/m} + (\text{stud shear force})$$

For section b-b at a joint in the sheeting,

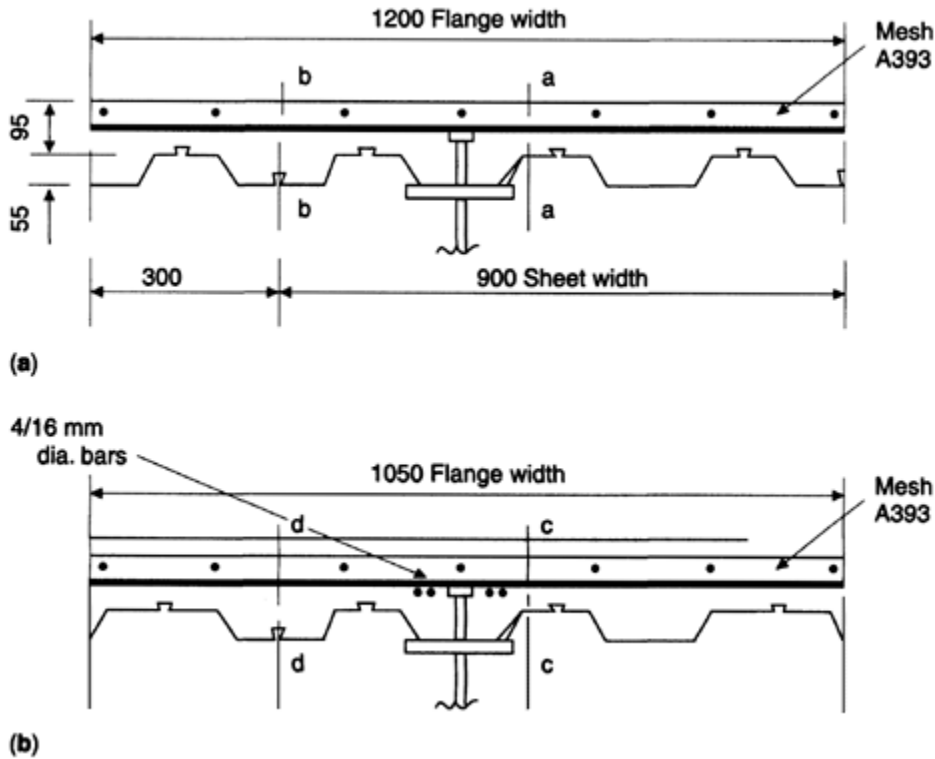

Fig. 6.15 Moments: (a) positive; (b) negative.

$$v_r = 81.1 + (0.03 \times 150 \times 30) = 216.1 \text{ kN/m}$$

$$> 180 \text{ kN (half the stud shear force)}$$

Both sections are satisfactory.

(b)  
Negative moments (Figure 6.15 (b))

For section c-c:

$$v = 9 \times 60 = 540 \text{ kN}$$

For section d-d:

$$v = 270 \text{ kN}$$

This is satisfactory.

### 6.7.7 Deflection (Clause 6.1.1)

The beam is unpropred. Deflections are based on properties of:

- dead load (self-weight of concrete and steel beam) on the steel beam;
- imposed load on the composite section.

(a)  
Dead load on steel beam

Referring to Figure 6.16(a) and section 6.7.1,

$$M_B = (0.15 \times 76.8 \times 6) + (0.1 \times 3 \times 6) = 70.9 \text{ kNm}$$

The deflection at the centre of the end span is

$$\delta_E = \frac{W_1 L^3}{48EI} + \frac{W_2 L^3}{384EI} - \frac{M_B L^2}{16EI} = 4.3 \text{ mm}$$

where, for 457 × 152 UB 52,  $W_1 = 76.8 \text{ kN}$ ,  $W_2 = 3 \text{ kN}$ ,  $M_B = 70.9 \text{ kNm}$ ,  $L = 6 \text{ m}$ ,  $E = 205 \text{ kN/mm}^2$ ,  $I = 21300 \text{ cm}^4$ .

(b)  
Imposed load on composite beam (Clause 6.13.2)

Referring to Figure 6.16(b) and section 6.7.1, to allow for pattern loading, the beam is loaded on all spans with the unfactored imposed load. The support bending moment is reduced by 30% to give

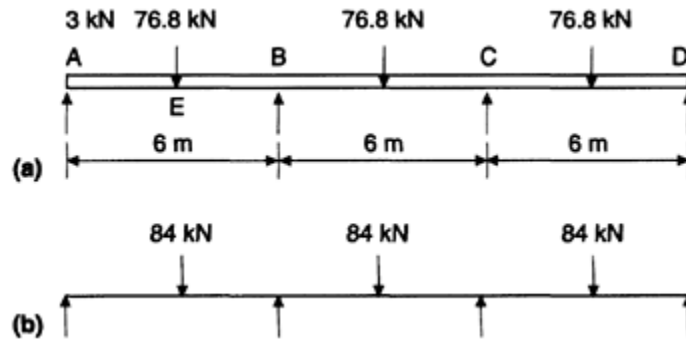

Fig. 6.16 Loads: (a) dead—steel beam; (b) imposed—floor.

(c)  
Transformed section

Referring to section 6.7.3,  $I_G=58959 \text{ cm}^4$ .

(d)  
Deflection calculation (Clause 6.1.3.5)

Simple beam deflection due to the imposed load

$$\delta_0 = \frac{84 \times 10^3 \times 6000^3}{48 \times 205 \times 10^3 \times 58\,060 \times 10^4} = 3.18 \text{ mm}$$

The maximum moment in simply supported beam is

$$M_0 = 84 \times 6 / 4 = 126 \text{ kNm}$$

$$M_1 = M_B = 52.9 \text{ kNm}$$

for a continuous beam with symmetrical point loads,

$$\delta_c = 3.18(1 - 0.6 \times 52.9 / 126) = 2.38 \text{ mm}$$

This is very small. The beam is larger than required.

# CHAPTER 7

## Tall buildings

### 7.1

#### GENERAL CONSIDERATIONS

The United States has always been the leader and chief innovator in the construction of tall buildings; a number of structures upwards of 400 m with 100 stories have been built. Many tall buildings have arisen in recent times in Singapore, Hong Kong, Europe and Australia.

Three modern advances have contributed to making tall building architecture safe and such an outstanding success:

- the design of efficient lateral load-resisting systems which are an essential component of all such structures to resist wind and seismic loads, reduce sway and damp vibration—many ingenious systems have been devised;
- the power of modern methods of computer analysis including modelling the structure for static and dynamic analysis, coupled with model testing in wind tunnels and on shaking tables so that behaviour can be accurately predicted;
- the development of rapid construction methods in concreting, pre-fabrication techniques, drainage provision etc.

Tall buildings are mainly constructed in city centres where land is in short supply; high population density coupled with high land prices and rents make their adoption economical. In provision of housing, one tall building can replace a large area of low-rise buildings, which can make way for other developments such as community centres, sports centres or open parkland. Tall buildings are used for offices, banks, hotels, flats, schools, hospitals, department stores etc. and often for combined use, e.g. offices/apartments.

Architects and engineers planning a tall building need to consider the following general constraints on design.

- Building regulations and planning laws for the city concerned— sometimes the maximum building height is limited.
- Intended occupancy—this governs the floor loading and influences the structural arrangement adopted. For example, in multistorey flats and hotels the division floor space can be the same on each floor and vertical loadbearing walls throughout the height of the building can be introduced. Masonry or concrete-framed structures are most often but not always adopted in these cases. In office buildings, banks, stores etc. the core/perimeter wall building, where space division if required can be made by lightweight demountable partitions, is the most suitable solution.
- The transport of people is primarily vertical, requiring either a central core or shear wall/core areas at appropriate locations where lifts/ stairs/services are provided. The design of tall buildings was only possible following the invention of the electric lift.
- Fire protection of the structural frame in steel buildings is mandatory, as is the provision of separate fireproof compartments for lifts and stairs. Limits are set on compartment sizes to prevent spread of fire. All buildings must be fitted with sprinklers and be capable of easy and speedy evacuation. The design must comply with all relevant regulations.
- Heating or air conditioning is essential, depending on location. This requires space between floor slabs and suspended ceilings and in curtain walls and cores to accommodate ducts and pipes.
- Provision of services (lighting, power, telephone, television, computer networks, water, waste disposal) forms an important part of design and must be considered at the planning stage. Services can be in-corporated in prefabricated wall and floor units during manufacture.



## 7.2

## STRUCTURAL DESIGN CONSIDERATIONS

In the structural engineering sense, the multistorey building may be defined as tall when the horizontal loading due to wind or seismic effects becomes the most important consideration in design. This is particularly the case with modern buildings clad with lightweight curtain walling and using lightweight partitioning and fire protection.

The frame must be stiff enough to limit deflection to  $1/300$  of the height of each storey to prevent sway causing anxiety to the occupants. This limitation is of prime importance in very tall buildings and has led to the development of special structural forms such as the tube type of building described below. Multistorey rigid frame construction alone without shear walls/core is not suitable for very tall buildings because of excessive deflection.

Buildings can be entirely in steel framing with appropriate bracing or construction system to provide lateral load resistance. More often, buildings are a composite of steel framing and concrete shear walls or cores where one function of the concrete elements is to carry lateral loads. Concrete has the additional advantage of fire resistance. Steel requires protection with casing or spray-on treatment.

The steel-framed building with composite steel deck/flooring, prefabricated cladding panels, lightweight demountable internal partitions, suspended ceilings and lightweight fire protection is ideally suited to the use of industrialized building techniques. The advantages of this type of construction are accuracy of shop fabrication of units and speed of erection with maximum site labour and few specialized skills.

The foundations can be expensive depending on site conditions because heavy loads are delivered onto small areas. Cellular rafts or multistorey basement foundations are commonly used where the space under the building provides car parking. The foundations may bear directly on the soil or be supported on piles or on caissons under thick cap slabs.

Very often the erection of the structure has to be carried out on a restricted site. This influences the design and limits the size of components to be fabricated. Very large transfer girders are needed in some designs where the plan and column arrangement change in the building height and special erection provisions are needed. Low- to medium-rise buildings can be erected with independent tower cranes located around the plan area. For tall buildings, erection must make use of the structure itself. In core buildings, the concrete core can be constructed first by slip forming and then used to erect the steelwork. Alternatively, climbing cranes can erect the steelwork on itself and the steel can progress ahead of the concrete shear walls or cores.

It is difficult to compare costs of different systems. Frame costs can be compared, but all factors, including foundations, flooring, cladding, partitions, fire protection, services, operating and maintenance costs should be included. The steel frame cost may not exceed 25% of the total building cost. All systems set out below continue to be used. Some preliminary comparative designs are given.

## 7.3

## STRUCTURAL SYSTEMS

The main structural systems used for tall buildings are discussed below. The classification of the various types is based primarily on the method adopted to resist horizontal loading. A second classification is concerned with the method of construction used. Combinations of various types can be adopted. Both steel-framed only and composite structures are described (Hart *et al.* 1978; Orton, 1988; Taranath, 1988).

## 7.3.1

**All-steel braced structure**

In its simplest form, bracing forms a vertical cantilever which resists horizontal load. The simple method of design involving only manual analysis can be used for the whole structure for buildings braced with one or more cantilever trusses (Figure 7.1). The braced bays can be grouped around a central core, distributed around the perimeter of the building or staggered through various elevations. The floors act as horizontal diaphragms to transmit load to the braced bays. Bracing must be provided in two directions and all connections are taken as pinned. The bracing should be arranged to be symmetrical with respect to the building plan, otherwise twisting will occur.

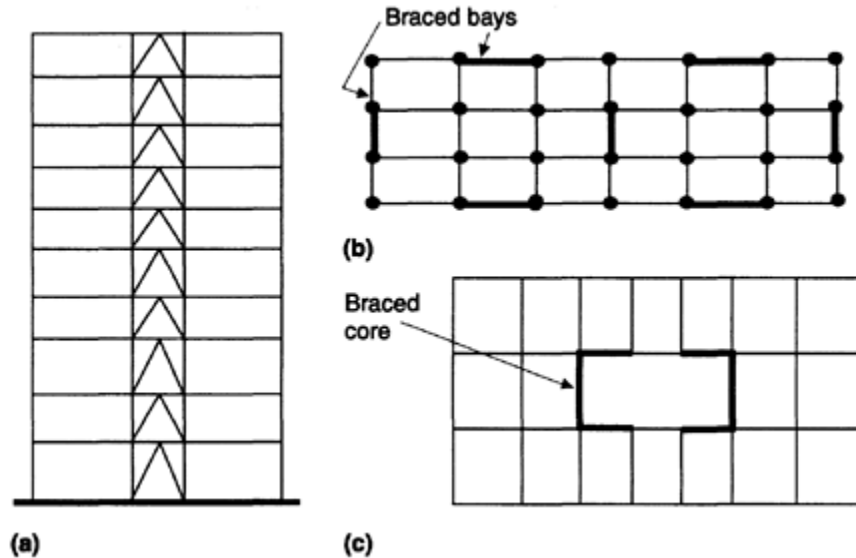

Fig. 7.1 All-steel braced structures: (a) vertical bracing; (b) bracing on perimeter/interior walls; (c) bracing around core.

### 7.3.2

#### Rigid frame and mixed systems

(a)

*Rigid frame structures (Figure 7.2 (a))*

In rigid frame structures the horizontal load is resisted by bending in the beams and columns. The columns, particularly in the lower stories, must resist heavy moments so sections will be much larger than in braced buildings.

The frame normally has H-section columns. It is rigid in one direction only, across the short span, and is braced longitudinally. The connections are expensive, being welded or made with haunched beam ends and high-strength bolts. Frames rigid in both directions with box section columns have been constructed in areas subject to seismic loads.

The rigid frame structure deflects more than a braced structure. The deflection is made up of sway in each storey plus overall cantilever action. Due to excessive deflection, rigid frames are suitable only for low- or medium-rise buildings.

(b)

*Mixed systems (Figure 7.2 (b)–(d))*

A mixed braced frame/rigid frame structure can also be adopted. This type occurs commonly in reinforced concrete constructions where the shear wall is combined with a concrete rigid frame.

The different modes of deflection for the cantilever/core/braced bay and rigid frame sway are shown in the figure.

(c)

*Staggered lattice girder system (Figure 7.2(e))*

This system, developed in the United States, is useful for long narrow buildings with central corridor, e.g. hotels or offices. Storey-deep lattice girders, staggered on adjacent floors, span between wall columns as shown in the figure. Lateral loads can be resisted in two ways:

- by end-braced bays with floors acting as rigid diaphragms;
- by rigid frame action in the transverse frames which can be analysed by a matrix computer program.

In the longitudinal direction, braced bays on the outside walls or shear walls at lifts/shafts/stairwells improve stability.

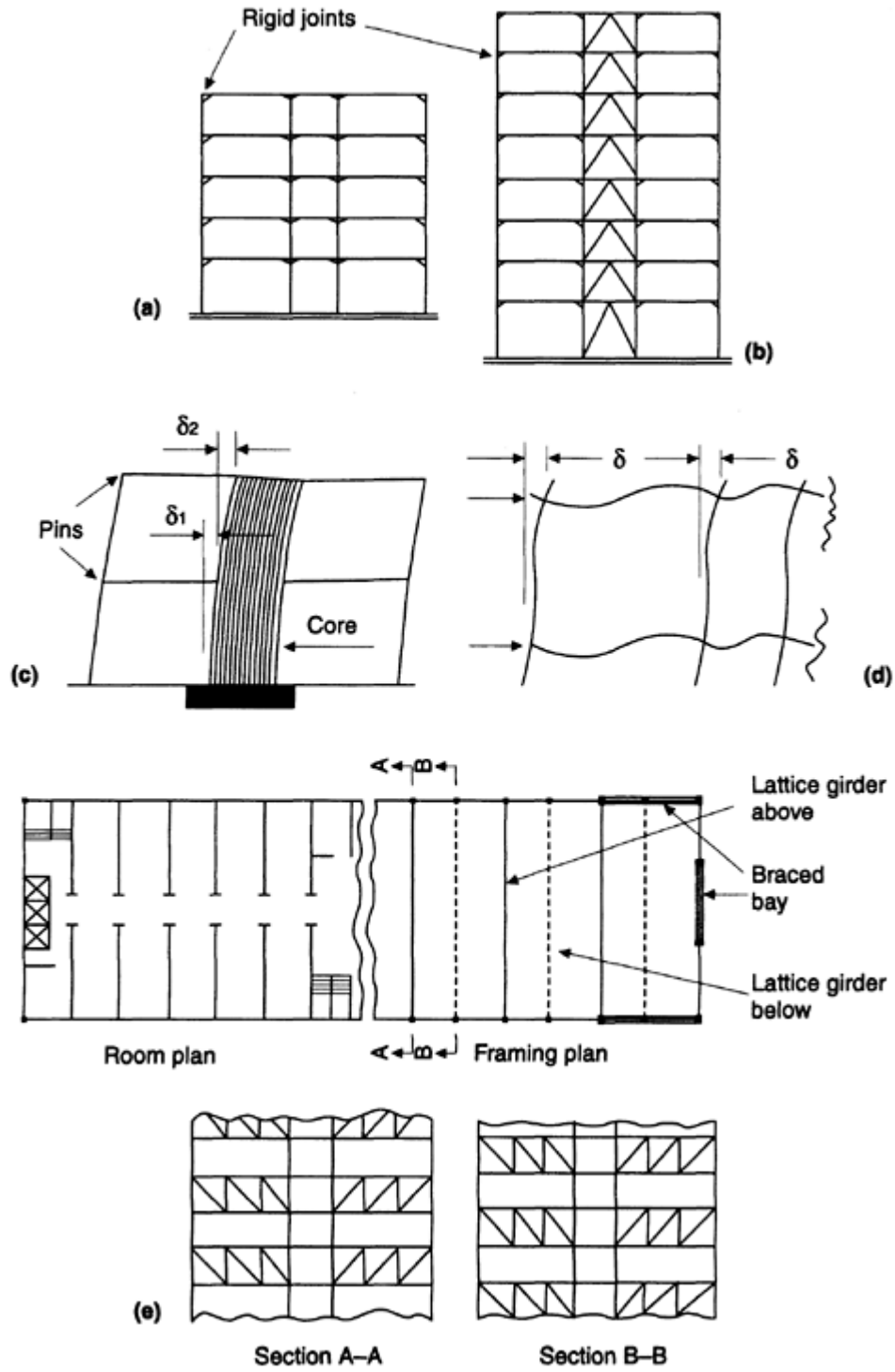

Fig. 7.2 Construction systems: (a) rigid frame; (b) rigid frame with bracing; (c) cantilever deflection; (d) rigid frame deflection; (e) staggered lattice girder.

### 7.3.3

#### All-steel outrigger and belt truss system

In tall buildings, the lateral deflection can be excessive if the bracing is provided around the core only. This can be reduced by bringing the outside columns into action by the provision of outrigger and belt lattice girders, as shown in Figure 7.3. The tension and compression forces in the outer columns apply a couple to the core which acts against the cantilever bending

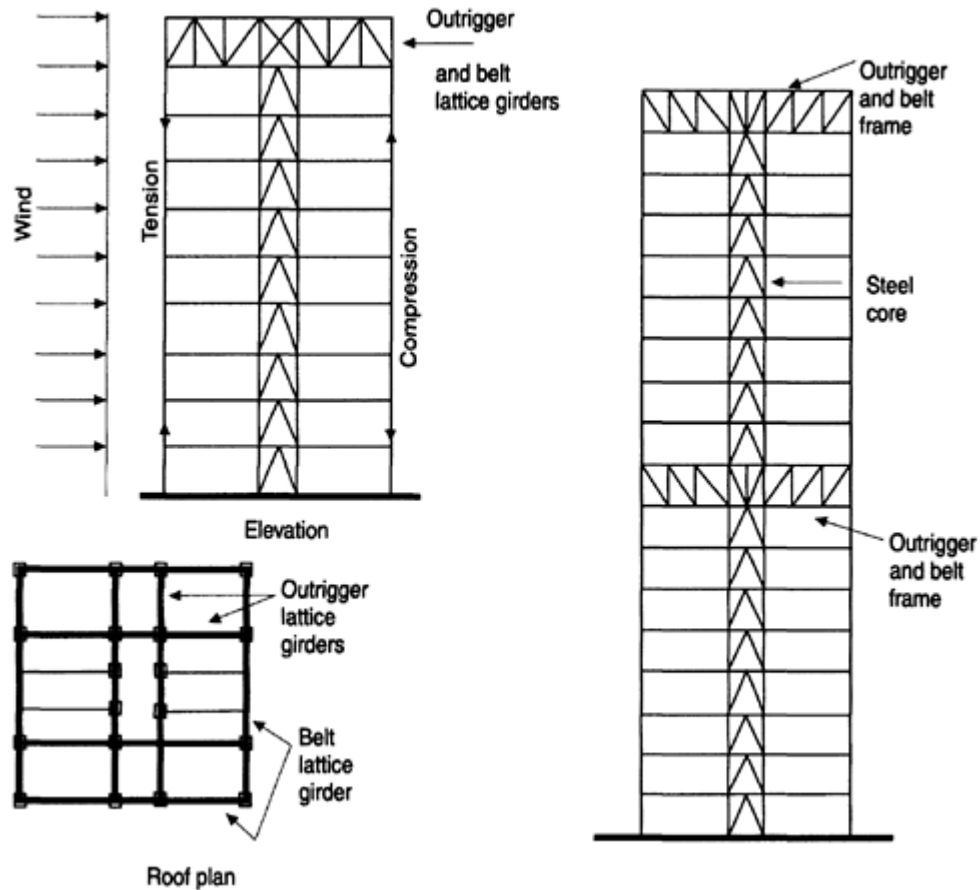

Fig. 7.3 Outrigger and belt lattice girder system.

under wind loads. The belt truss surrounding the building brings all external columns into action. A single outrigger and belt lattice girder system at the top or additional systems in the height of very tall buildings can be provided.

#### 7.3.4.

#### Composite structures

(a)

*Concrete shear wall structures (Figure 7.4)*

The composite steel-shear wall structure consists of a steel-framed building braced with vertical reinforced concrete shear walls. The shear walls placed in two directions at right angles carry vertical and horizontal loads. The shear walls replace the braced bays in the all-steel building.

The shear walls can be located at the ends or sides or in appropriate locations within the building. They should be arranged to be symmetrical with respect to the plan, otherwise twisting will occur. They provide fireproof walls at lifts and staircases. The walls may be reinforced concrete or concrete-cased steel sections and are designed in accordance with BS 8110 and BS 5950.

(b)

*Concrete core structures (Figure 7.5)*

The steel frame with concrete core structure is a very common building type adopted for city centre offices. Many of the important features have already been mentioned. The main advantages are as follows.

- The space between core and perimeter is column-free, resulting in maximum flexibility for division using lightweight partitions.
- The core provides a rigidly constructed fire-resistant shaft for lifts and staircases.

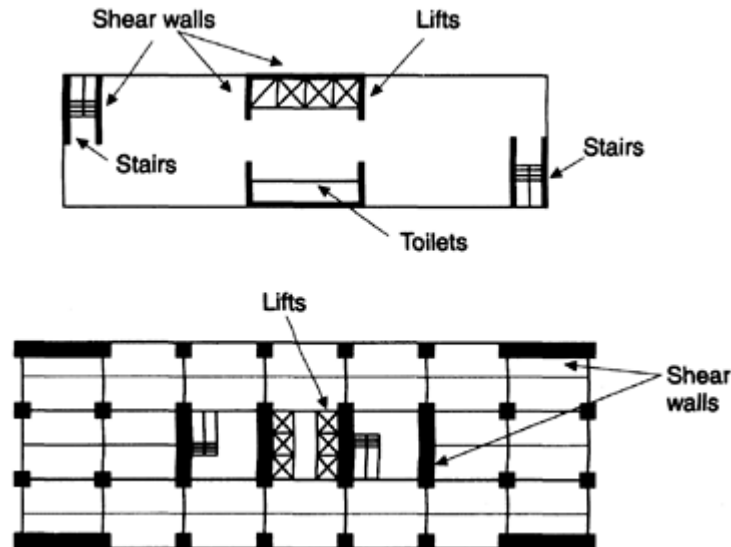

Fig. 7.4 Steel building with concrete shear walls.

- No bracing is required on the perimeter walls, so the facade treatment is uniform on all faces.

The structured action is clearly expressed in that the core is designed to resist all the wind loads on the building, the core loads from lifts, stairs etc. and part of the floor loads. The floor plan may be square, rectangular, triangular, circular, etc. The floor steel may be:

- supported on the core and perimeter columns;
- cantilevered out from the core;
- suspended from an umbrella girder at the top of the core (Section 7.3.5).

Construction is rapid, using slip forming for the core, which is then used to erect the building. Construction can be carried out within the area of the building.

The core may be open or closed in form. Closed box or tubular cores are designed as vertical cantilevers. Open cores, generally of channel or H-section, are designed as connected cantilever shear walls. Cores may be of reinforced concrete, composite steel and concrete with steel columns at extremities or cased steel sections.

Where floor girders are cantilevered out from the core, two possible arrangements are as follows.

- In a circular building, the girders can be supported from steel columns embedded in the core (Figure 7.5 (a)). The concrete core resists wind load.
- In a square building, the cantilever girders on adjacent floors can be arranged to span at right angles to each other. This avoids the need for cantilevers to cross each other at right angles. The two edge beams on any floor parallel to the cantilevers on that floor are then suspended by hangers from the floor above (Figure 7.5 (b)).

### 7.3.5

#### Suspended structures (Figure 7.6)

In suspended structures, an umbrella girder is provided at the top of the core from which hangers for the outer ends of the floor beams are suspended. In very tall buildings, additional umbrella girders can be introduced at intermediate locations in the height.

All loads, both vertical and horizontal, are carried on the core in suspended structures. Sections, bars in high-strength steel or cables are used for the suspension members. The time for erection can be shorter than for a conventional structure built upwards. The core is constructed first by slip forming and used to erect the steelwork.

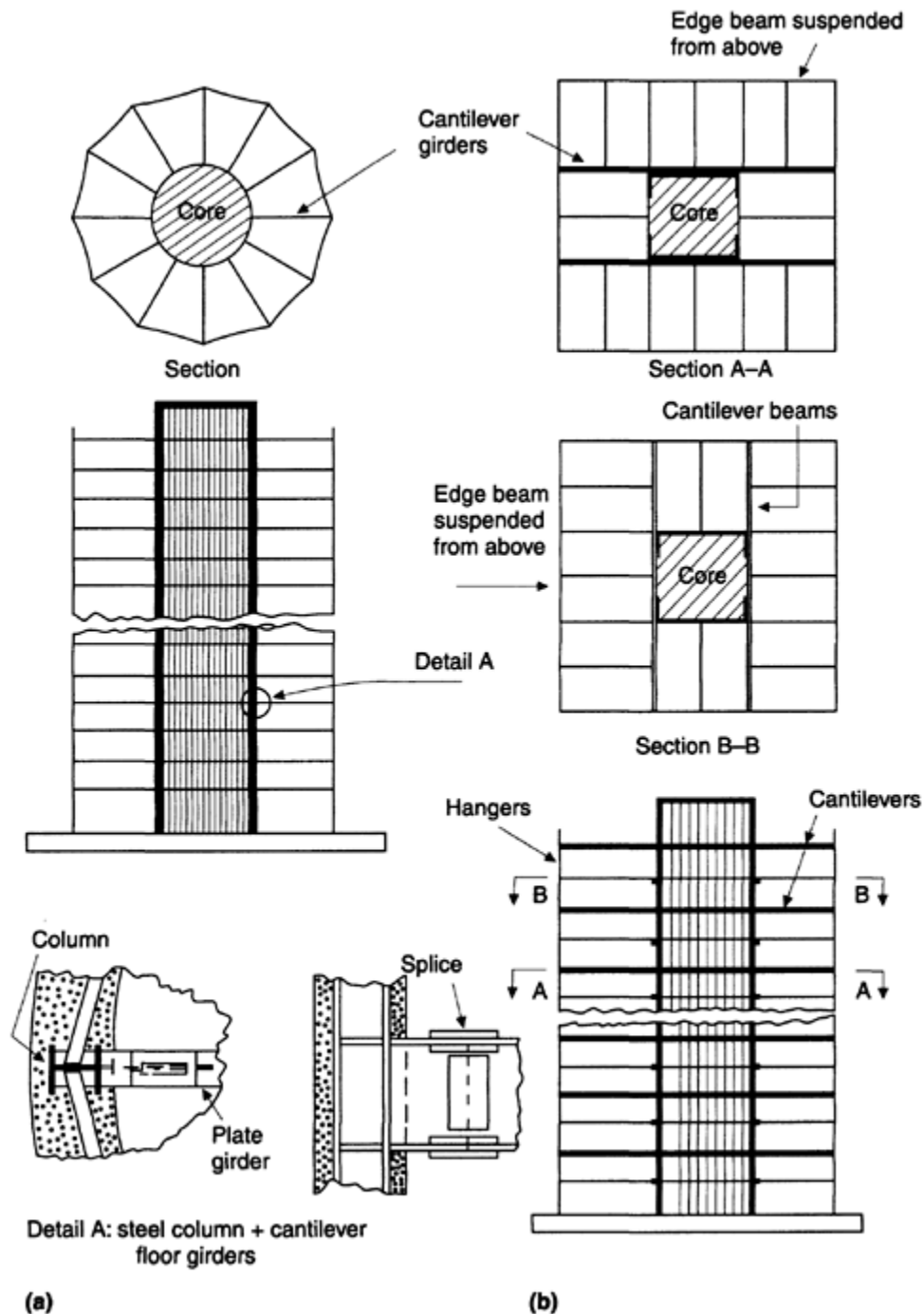

Fig. 7.5 Buildings with cantilevered floors: (a) circular building; (b) square building.

### 7.3.6

#### Tube structures

The tube type of structure was developed by Dr. Fazlur Khan of the USA for very tall buildings, say over 80 storeys in height. If the core type of structure is used, the deflection at the top would be excessive. The tube system is very efficient with respect to structured material used and results in a considerable saving in material when compared with conventional designs.

In this system the perimeter walls are so constructed that they form one large rigid or braced tube which acts as a unit to resist horizontal load. The framed tube shown in Figure 7.7 (a) consists of closely spaced exterior columns 1–3 m apart, tied at each floor level with deep floor beams. The tube is made up of prefabricated wall units of the type shown in Figure 7.7 (b). The small perforations form spaces for windows and the normal curtain walling is eliminated.

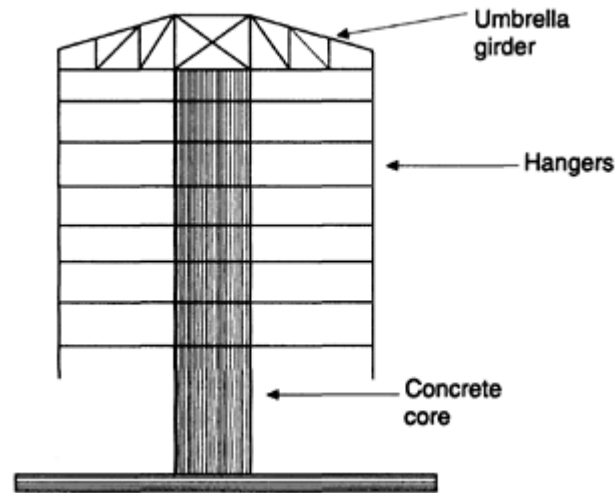

Fig. 7.6 Suspended structure.

In the single-tube structure, the perimeter walls carry all the horizontal load and their share of the vertical load. Internal columns and/or an internal core, if provided, carry vertical loads only. In the tube-within-a-tube system shown in Figure 7.7 (e), the core tube would carry part of the horizontal load. Very tall stiff structures have been designed on the bundled tube system shown in Figure 7.7 (f), which consists of a number of tubes constructed together. This reduces the shear lag problem which is more serious if a single tube is used.

The analysis of a tube structure may be carried out on a space frame program. The main feature shown up in the analysis for horizontal load is the drop-off in load taken by the columns in the flange faces. This is caused by shear lag in the beam-column frame as shown in Figure 7.7 (c). Simple beam theory would give uniform load in these columns. Dr Fazlur Khan developed preliminary methods of analyses which take shear lag into account (Khan and Amin, 1973).

The framed tube can be relatively flexible and additional stiffness can be provided by bracing the tube as shown in Figure 7.7 (c). This helps reduce shear lag in the flange tube faces.

### 7.3.7

#### SWMB structures

A brief description is given of a building system for tall buildings developed by Skilling Ward Magnusson Barkshire Inc. of Seattle, USA (Skilling, 1988)—the SWMB system. The basis of the design is that it is far cheaper to use concrete rather than steel members to carry vertical loads. A dramatic saving in weight of steel used is possible.

Central to the system is the SWMB column which consists of a very large (up to 3 m diameter) concrete-filled tube. Three, four or more such columns connected by deep girders and moment frames extend through the height of the building and carry vertical and horizontal loads.

The concrete infill in the column is of very high strength ( $140 \text{ N/mm}^2$ ) from a mix with small aggregate, low (0.22) water/cement ratio and superplasticizer giving a 300 mm slump. The concrete is pumped in under pressure from the bottom and rises up the column. Stud shear connections are welded to the inside to ensure composite action and efficient load transfer. Special stiffeners and connection plates are welded to the tubes for girder and moment connections. The tubes are shop fabricated in three-storey-high sections and welded together on site using splice rings.

## 7.4

### CONSTRUCTION DETAILS

To assist in idealizing the structure for design, some of the common construction forms for the various building elements are set out briefly.

#### 7.4.1

##### Roofs and floors (Figure 7.8 (a))

Floor construction was discussed in Chapter 6. The main types used for flat roofs and floors are:

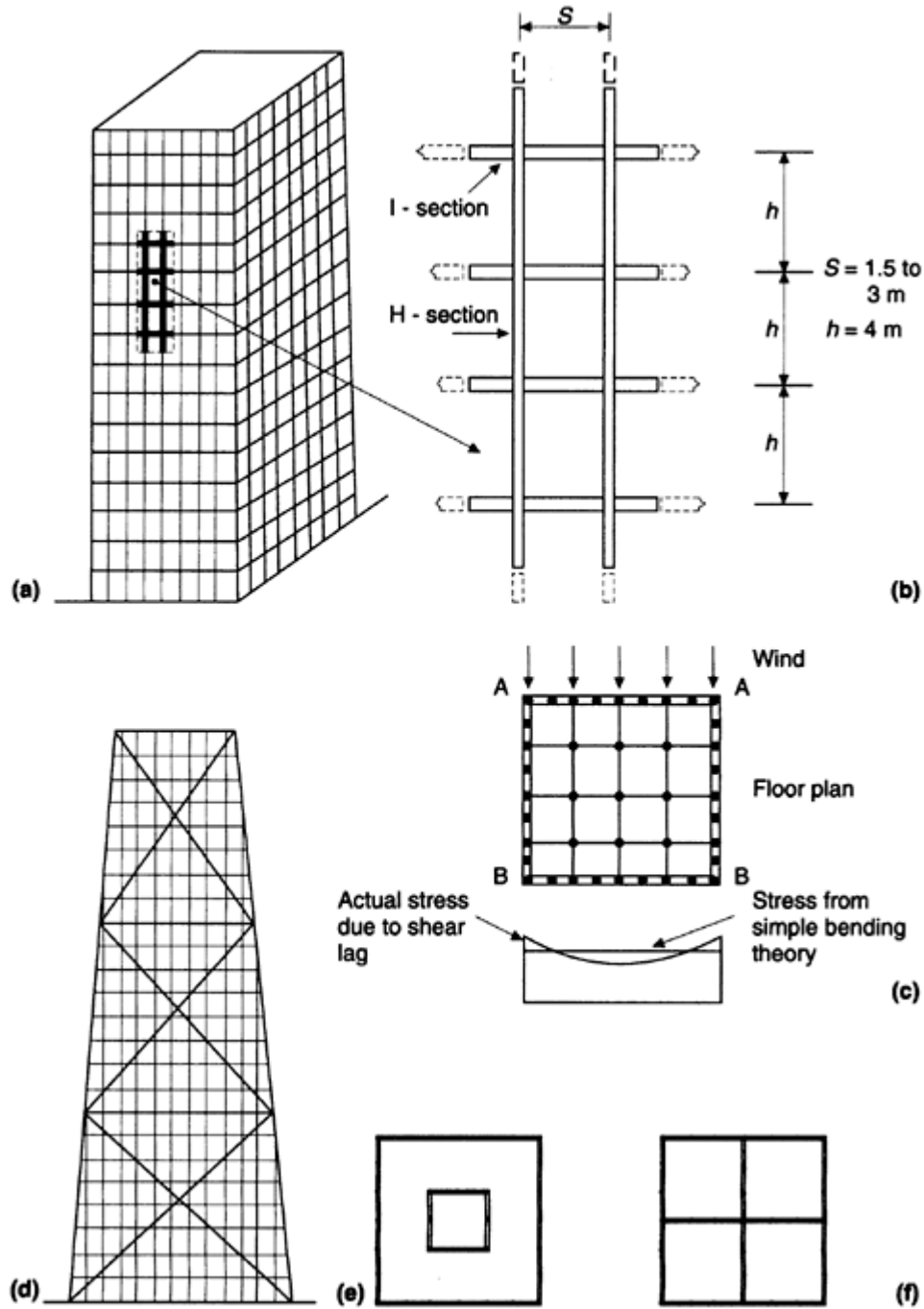

**Fig. 7.7** Tube structures: (a) framed tube; (b) prefabricated 'tree' unit; (c) stress distribution in walls AA, BB; (d) braced tube; (e) tube in tube; (f) bundled tube. (Buildings may have more storeys than shown.)

- *Cast-in-situ* or precast concrete slabs or steel beams;
- Composite *in-situ* concrete on steel deck on steel beams.

The steel beams are usually designed to act compositely with *in-situ* slabs. The use of lattice or steel girders permits services to be run through floors. Floor beams must have fire protection.



### 7.4.2 Walls

Walls in steel-framed buildings may be classified as follows.

- Structural shear walls located in bays on the perimeter, around cores or in other suitable areas—these are of reinforced concrete or composite construction incorporating steel columns. All-steel braced bays with fireproof cladding serve the same purpose. These walls carry wind and vertical load.
- Non-load bearing permanent division and fire-resistant walls—these are constructed in brick and blockwork and are needed to protect lifts, stairs and to divide large areas into fireproof compartments.
- Movable partitions—these are for room division.
- Curtain walls—these include glazing, metal framing, metal or precast concrete cladding panels, insulation and interior panels. Typical details are shown in [Figure 7.8\(b\)](#).
- Cavity walls with outer leaf brick, inner leaf breeze block—these are common for medium-rise steel-framed buildings.

### 7.4.3 Steel members

#### (a) *Floor beams*

Universal beams are generally designed as composite with concrete on steel deck floors. Compound beams, lattice girders, plate girders or stub girder construction are required for long spans. Heavy transfer girders are required where floor plans or column arrangements change.

#### (b) *Columns*

Universal columns, compound and built-up sections and circular and box sections are used. ARBED's heavy 'jumbo' sections are ideal for very tall buildings. (Trade ARBED Luxembourg, n.d..) Box columns external to the building can be protected from the effects of fire by circulating water to keep the temperature to a safe value.

#### (c) *Hangers*

Rounds, flats or sections in high-strength steel or steel cables are used.

#### (d) *Bracings*

All-steel, open or closed sections are used.

## 7.5 MULTISTOREY BUILDING—PRELIMINARY DESIGN

### 7.5.1 Specification

#### (a) *Design—Steel core and perimeter columns*

The framing plans for a 20-storey office building are shown in [Figures 7.9](#) and [7.10](#). The roofs and floors are cast-*in-situ* concrete slabs supported on steel beams. Curtain walls cover the external faces. The core walls are braced steel cantilevers

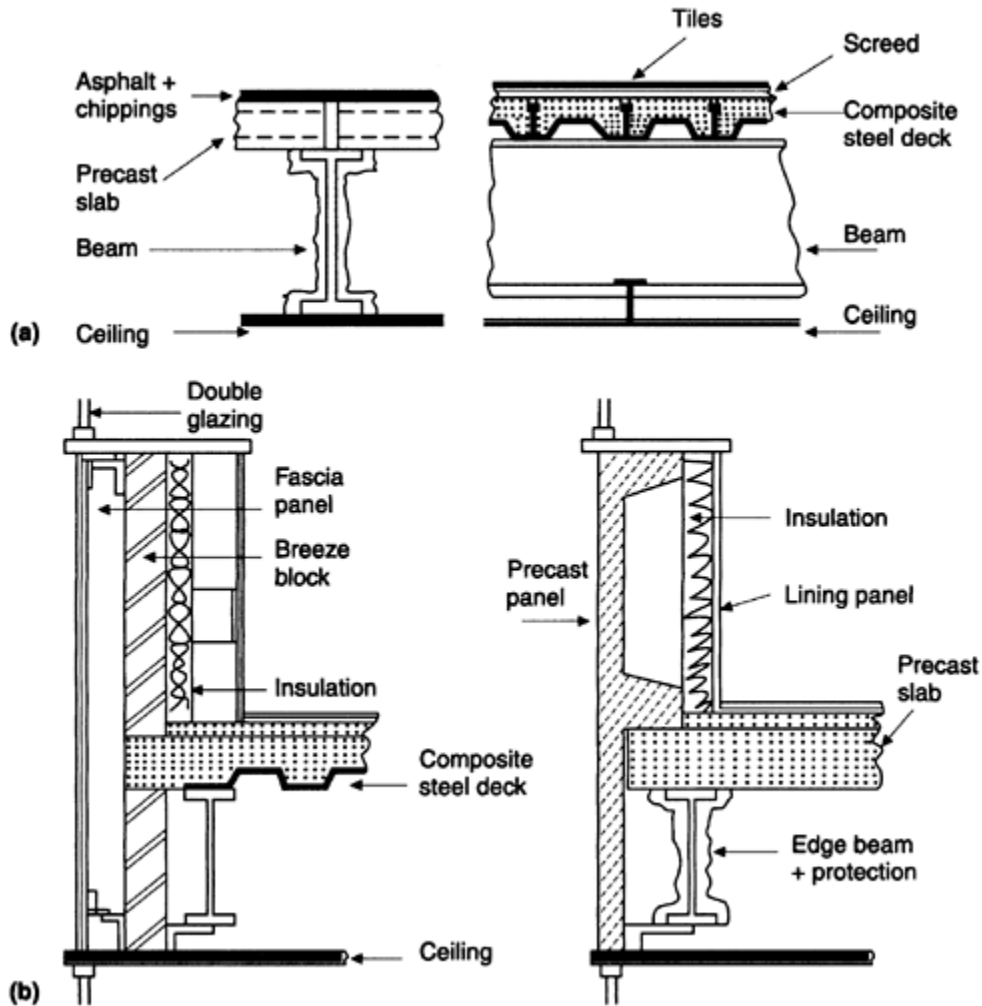

Fig. 7.8 Typical building details: (a) roof and floor construction: (b) curtain walls.

enclosed in breezeblock fire protection. The internal steel-framed walls in the core are of similar construction. Light-weight partitions provide division walls in the office areas. Services are located in the core.

The procedure is as follows.

1. Design floor beams and a perimeter column.
2. Check building stability and design bottom bracing member.

The material is to be steel, Grade 50.

(b)  
*Alternative designs*

The following alternative designs are possible:

- 1. steel core with cantilever floor beams;
- 2. suspended structure—perimeter hangers with concrete core and four umbrella girders (Figure 7.11)

### 7.5.2 Dead and imposed loads

Refer to BS 6394: Part 1 for details.

The loads are:

- roof—dead 5 kN/m<sup>2</sup>, imposed 1.5 kN/m<sup>2</sup>;
- floors—dead 6 kN/m<sup>2</sup>, imposed 3.5 kN/m<sup>2</sup>;
- core—dead 6 kN/m<sup>2</sup>, imposed 5.0 kN/m<sup>2</sup>;
- core (top machine floor)—dead 8 kN/m<sup>2</sup>, imposed 7.5 kN/m<sup>2</sup>;
- walls—
  - curtain walls, glazing, steel 5 kN/m
  - internal and access core walls 10 kN/m
  - braced core walls 15 kN/m
  - parapet 3 kN/m;
- columns—
  - perimeter with casing 1.4–5 kN/m
  - core (average) 3 kN/m.

The reduction in total distributed imposed load with number of storeys (Table 2 or BS 6399: Part I) is:

- 5–10 floors—40%
- over 10 floors—50%.

Note that the lifts and machinery are carried on independent columns within the core.

### 7.5.3 Beam loads and design

#### (a) Office floor beams—design

The office floor beam layout and beam loads are shown in [Figure 7.12](#).

$$\text{Design load}=(1.4 \times 6)+(1.6 \times 3.5)=14 \text{ kN/m}^2$$

#### (i) Beam FB1 (FB4 similar)

$$\text{Design load}=(1.77 \times 9.9 \times 14)+(5 \times 10.35 \times 1.4)=317.8 \text{ kN}$$

$$\text{Imposed load}=61.3 \text{ kNm}=317.8 \times 10.35 / 8=411.2 \text{ kNm}$$

$$S=411.2 \times 10^3 / 355=1158 \text{ cm}^3$$

Select 457×152 UB 60, with  $S=1280 \text{ cm}^3$ . Deflection satisfactory.

#### (ii) Beam FB2 (FB5 similar)

$$\text{Design load}=418.8 \text{ kN}$$

$$\text{Imposed load}=104.7 \text{ kNm}=442.4 \text{ kNm}, S=1246 \text{ cm}^3$$

Try 457×152 UB 60, with  $S=1280 \text{ cm}^3$ ,  $I=25500 \text{ cm}^4$ .

$$\delta = \frac{5 \times 104.7 \times 10^3 \times 8450^3}{384 \times 205 \times 10^3 \times 25500 \times 10^4} = 15.7 = \text{Span}/538$$

This is satisfactory.

#### (iii) Beam FB3 (FB6 similar)

$$\text{Design load}=325.6 \text{ kN}$$

$$\text{Imposed load}=81.3 \text{ kN}$$

Select 406×140 UB 46.

#### (iv) Beam FB7

$$M=3.67 \times 362.1=1328 \text{ kNm}$$

$$S=1328 \times 10^3 / 345=3849 \text{ cm}^3$$

Try 686×245 UB 125, with  $S=4000 \text{ cm}^3$ ,  $T=16.2 \text{ cm}$ ,  $p_y=345 \text{ N/mm}^2$  (as assumed),  $T=118000 \text{ cm}^4$ .

Deflection at the centre due to the unfactored imposed loads is

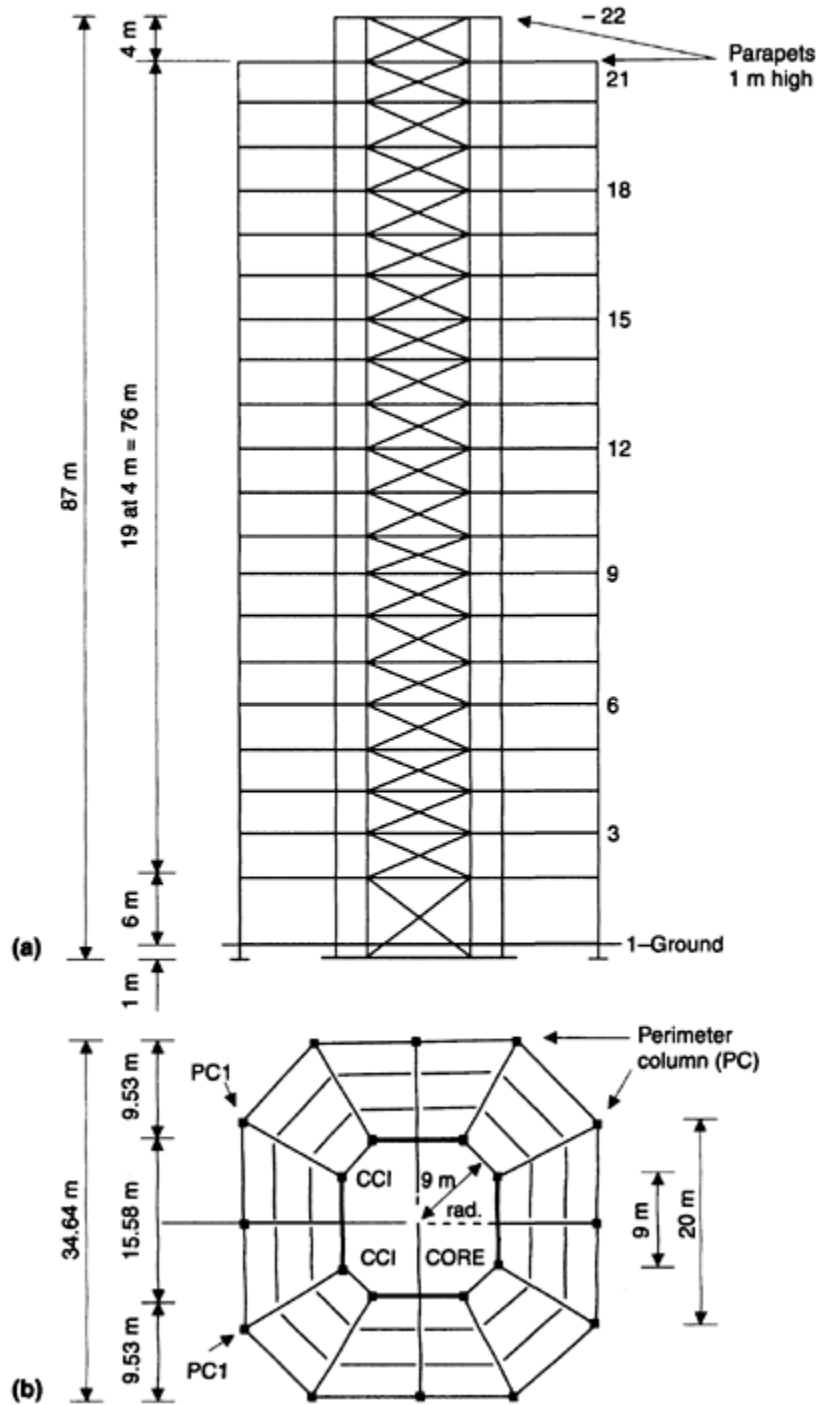

Fig. 7.9 Framing plans; (a) elevation; (b) floor plan.

$$\delta = \frac{(97.9 + 75.9)10^3 \times 11\,000^3}{48 \times 205 \times 10^3 \times 118\,000 \times 10^4} \left[ \frac{3 \times 3.67}{11} - 4 \left( \frac{3.67}{11} \right)^3 \right]$$

$$= 17 \text{ mm} = \text{Span}/647$$

This is satisfactory.

(v) Beam FB8

Select 610×229 UB 113.

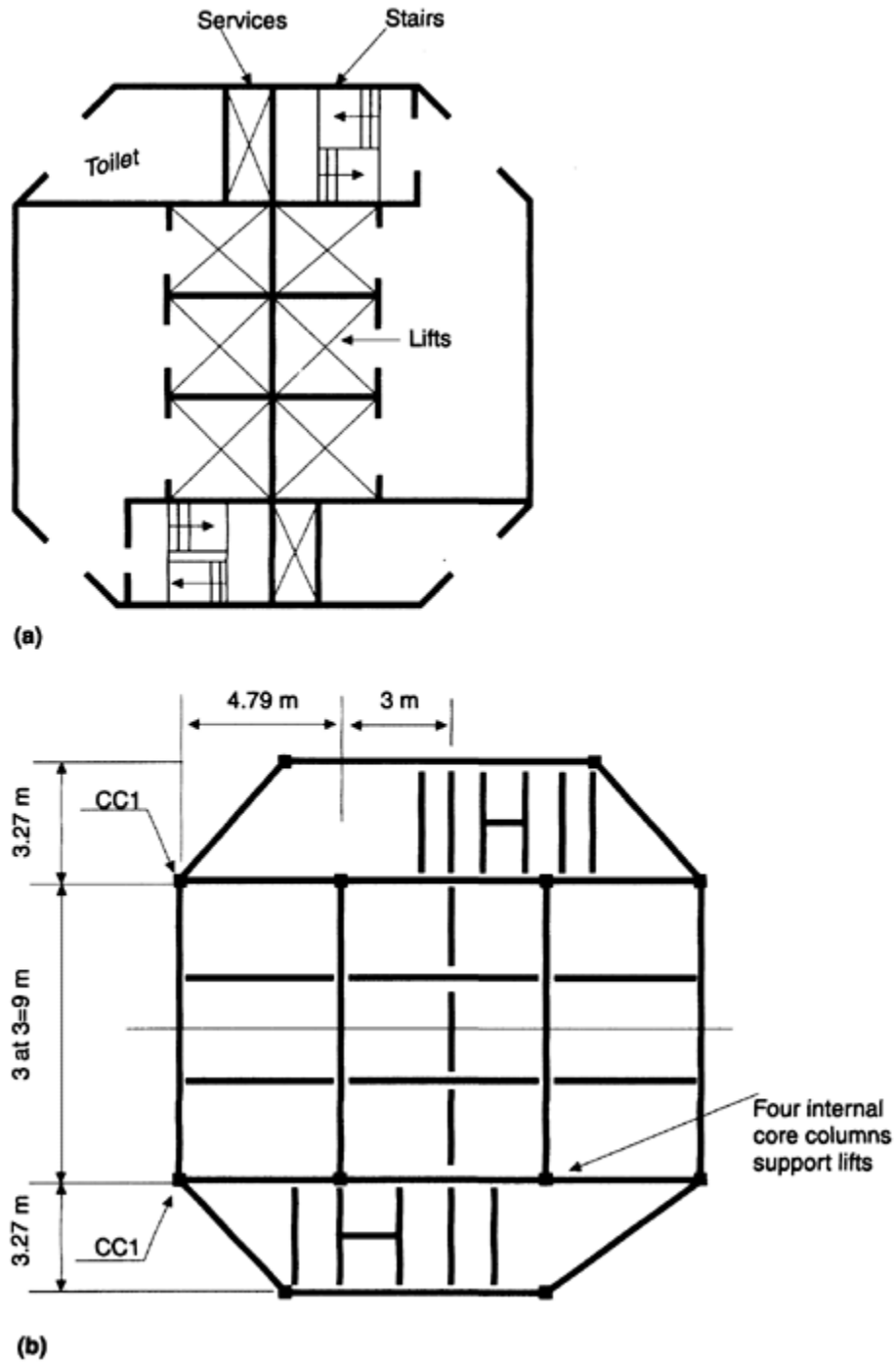

Fig. 7.10 Framing plans: (a) core arrangement; (b) core steel beams.

(b)

Roof beams—loads

The layout of the roof beams and the beam loads are shown in Figure 7.13.

$$\text{Design load} = (1.4 \times 5) + (1.6 \times 1.5) = 9.4 \text{ kN/m}^2$$

The beams could then be designed.

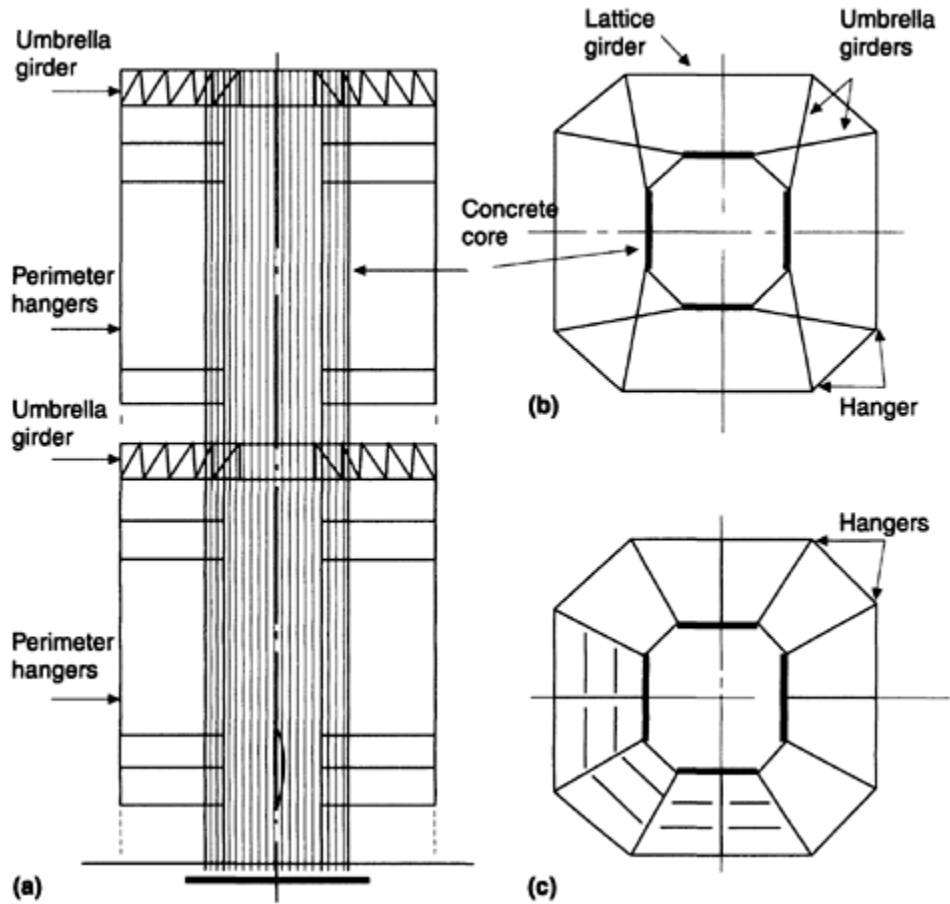

Fig. 7.11 Suspended structure: (a) elevation; (b) umbrella girders; (c) floor beams.

7.5.4

Design of perimeter column PC1

The column is shown in Figure 7.9. The column sections are changed at every third floor level from the roof down to floor 3 and then from floor 3 to base 1. The column sections are checked at the second level in the three-level length because the splice is made above floor level and the column below is of much heavier section which attracts the bulk of the eccentric moment.

The column loads at the critical sections are shown in Figure 7.14 and the eccentricities for the specimen calculations made are shown in Figure 7.15.

(a)  
Roof to floor 18

Check at floor 19. Reduce imposed load by 10%:

$$F = 1780 - (0.1 \times 224 \times 1.6) = 1758 \text{ kN}$$

Assume the column is 254×254 UC:

$$M_x = 0.5[(362.1 \times 0.24) + (158.9 \times 0.03) + (141.2 \times 0.06)] = 50 \text{ kNm} \quad M_y = 0.5 \times 0.23(160.3 - 142.2) = 2.0 \text{ kNm (neglect)}$$

Try 254×254 UC 73, with  $\square_y = 6.46 \text{ cm}$ ,  $S_x = 989 \text{ cm}^3$ ,  $A = 92.9 \text{ cm}^2$ ,  $T = 14.2 \text{ cm}$ ,  $p_y = 355 \text{ Nmm}^2$ . Also

$$\lambda_y = 0.85 \times 4000 / 64. \quad p_c = 268.2 \text{ N/mm}^2 \quad p_c A_g = 268.2 \times 92.9 / 10 = 2491.6 \text{ kN} \quad \lambda_{LT} = 0.5 \times 4000 / 64. \quad p_b = 352.5 \text{ Nmm}^2 \quad M_{bs} = 352.5 \times 989 / 10^3 = 348.6 \text{ kNm}$$

Then

$$(1758 / 2491.6) + (50 / 348.6) = 0.85$$

This is satisfactory.

Note that 203×203 UC 71 is too light.

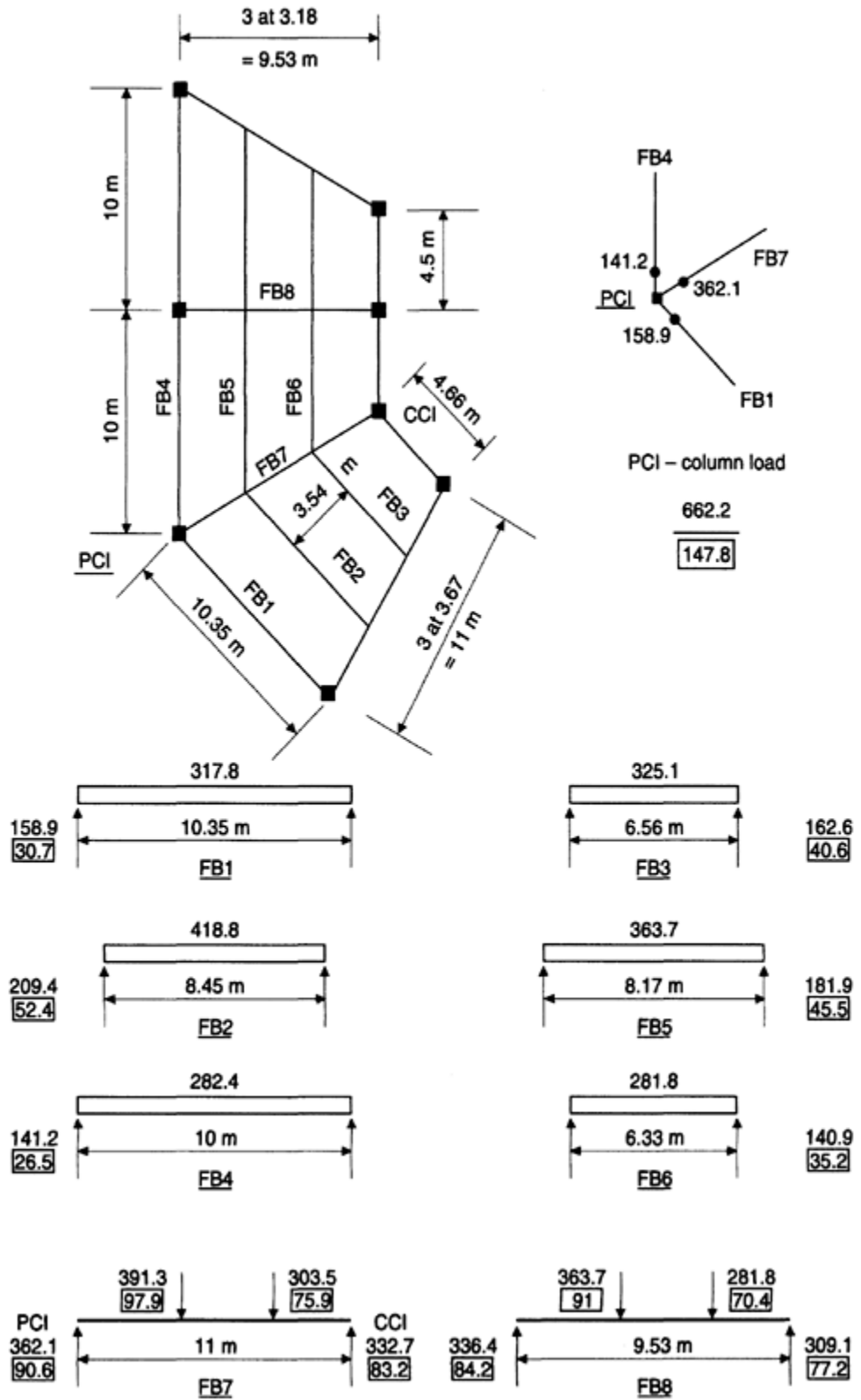

Fig. 7.12 Floor beam loads (kN; unfactored imposed loads shown boxed).

(b)  
Floors 18–3

The following sections are used:

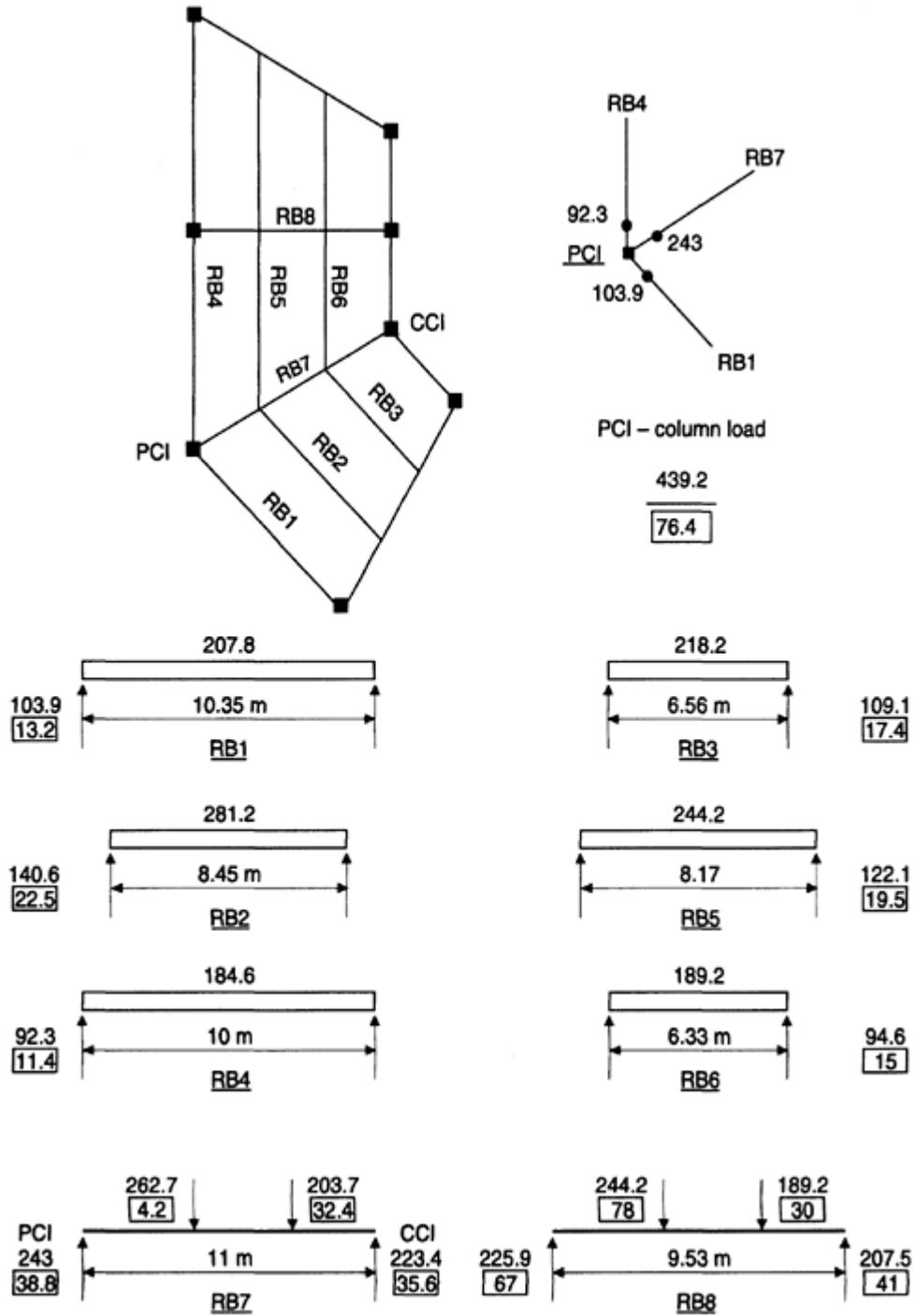

Fig. 7.13 Roof beam loads (kN; unboxed imposed loads shown boxed).

- Floor 18–15–305×305 UC 118;
- Floor 12–15–356×368 UC 153;
- Floor 12–9–356×368 UC 202;
- Floor 9–6–356×406 UC 235;
- Floor 6–3–356×406 UC 287.



Column	Floor	Total factored load	Unfactored imposed load	Reduction (%)	Design load
			211		
	20		224	10	
	19	1780			1758
	17		667	40	
	16	3803			3536
	14		1110	40	
	13	5826			5382
	11		1553	50	
	10	7861			7085
	8		1996	50	
	7	9908			8910
	5		2439	50	
	4	11967			10748
	3		2789	50	
	2	13347			11953

Fig. 7.14 Column PC1 loads.

(c)  
Floor 3—Base 1

$$F = 13347 - (0.5 \times 2789 \times 1.6) = 11953 \text{ kN}$$

$$\lambda_y = 0.85 \times 7000 / 105 = 56.7$$

$$p_c = 244.3 \text{ N/mm}^2, P_c = 12237 \text{ kN}$$

$$\lambda_{LT} = 0.5 \times 7000 / 105 = 33.3$$

$$p_b = 327.7 \text{ N/mm}^2, M_{bs} = 2697 \text{ kNm}$$

$$M_x = 0.5[(362.1 \times 0.31) + (141.2 \times 0.06) + (158.9 \times 0.03)] = 62.8 \text{ kNm}$$

$$(11953 / 12237) + (62.8 / 2697) = 0.99$$

This is satisfactory.

### 7.5.5 Braced core wall—vertical loads

The building stability is checked by considering the stability of the braced core wall CC1-CC1 (Figure 7.16(a)). The floor and column loads are calculated using the tributary area method.

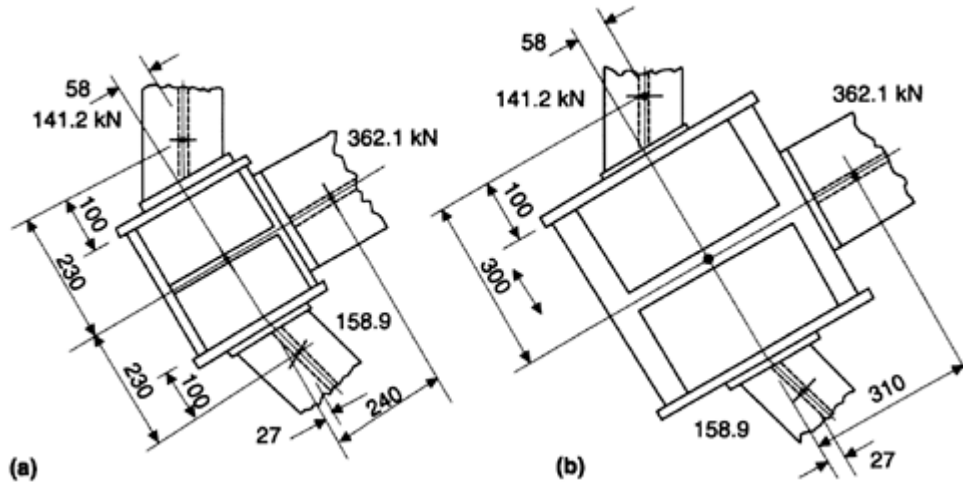

**Fig. 7.15** Column PC1 load eccentricities: (a) 254×254 UC 73, floor 19; (b) 356×406 UC 393, floor 2.

The dead loads are calculated for the office and core floors and walls.

The other loads are found by proportion (Section 7.5.2 gives load values). The loads on the separate areas and the reactions on core wall CC1-CC1 are shown in Figure 7.16 (b).

(a)

*Office floor—dead load*

Office area A : $9 \times 9.53 \times 6 = 514.6$ kN	+ $5.5 \times 9.53 \times 6 = 314.5$ kN
Office area B : $4.65 \times 11 \times 6 = 306.9$ kN	2.83 $\times 11 \times 6 = 186.5$ kN
Core floor area C : $9 \times 6 \times 4.79 / 2 = 129.3$ kN	Core floor area D : 32 kN (estimate)

(b)

*Walls and columns—dead load*

Braced core : $(15 \times 9 \times 20) + (15 \times 7.5 \times 9 / 3.5) + (3 \times 87 \times 2)$	= 2989 kN
Other walls : $10(4.79 + 4.65)20 + (10 \times 9.44 \times 7.5 / 3.5)$	= 2090 kN

(c)

*Separate loads—dead and imposed*

Office roof (dead) :	Office roof (imposed) :	Core roof (dead) :	Core roof (imposed) :	Machine floor (dead) :	Machine floor (imposed) :	Office floor (dead) :	Office floor (imposed) :	Core floor (dead) :	Core floor (imposed) :
$(362.1 + 215.7) / 5 = 481.5$ kN	$577.8 \times 1.5 / 6 = 144.5$ kN	$(129.3 + 32) / 5 = 134.4$ kN	$161.3 \times 1.5 / 6 = 40.3$ kN	$(129 + 32) / 8 = 215.0$ kN	$161.3 \times 7.5 / 6 = 201.6$ kN	$4 + 215.7 = 578.1$ kN	$578.1 \times 3.5 / 6 = 337.2$ kN	$129.3 + 32 = 161.3$ kN	$161.3 \times 5 / 6 = 134.4$ kN

(d)

*Total load at base of braced core wall*

Table 7.1 shows the dead and imposed loads at the core base.

### 7.5.6 Wind loads

Details are given BS 6399: Part 2.

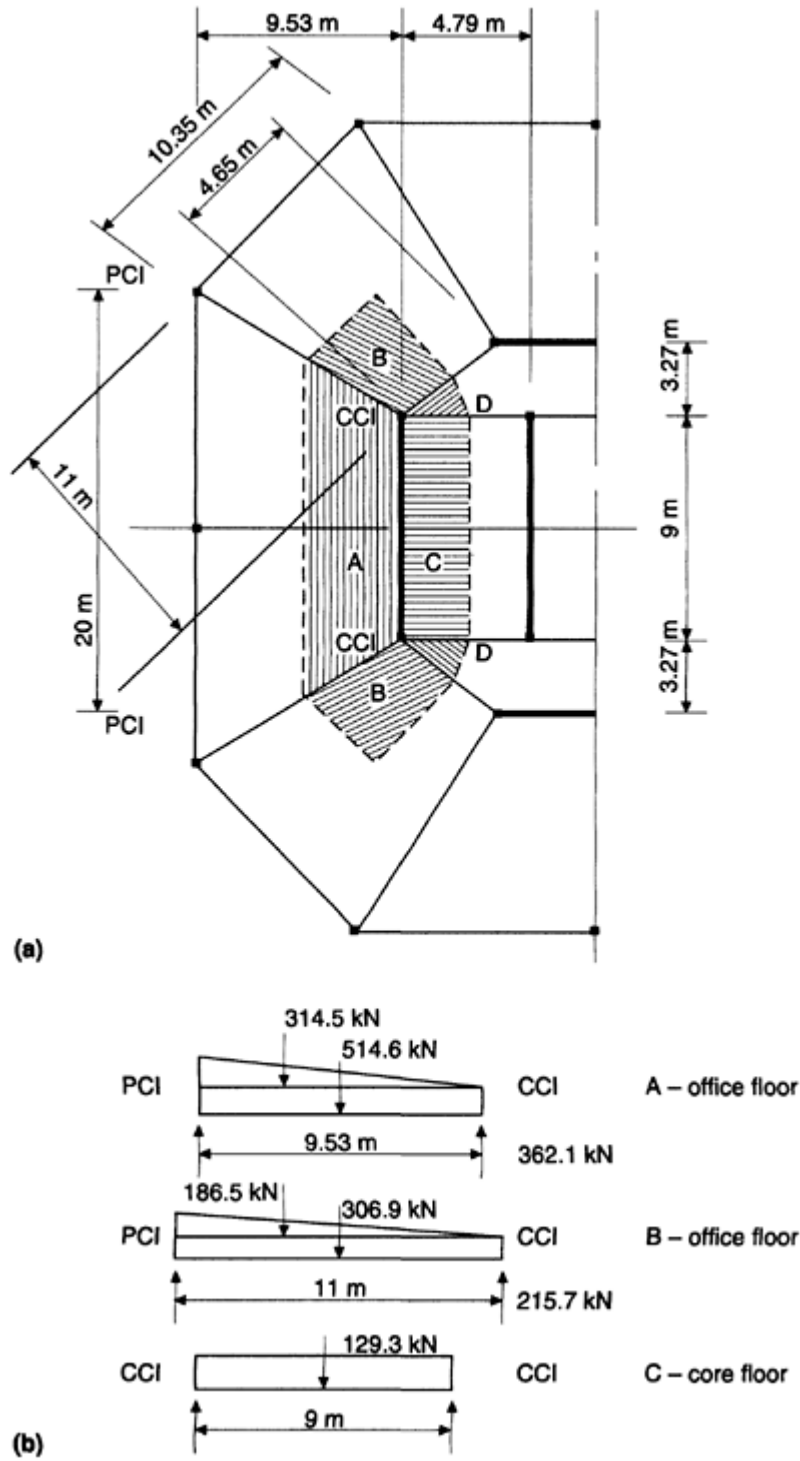

Fig. 7.16 Core wall stability: (a) tributary areas; (b) floor dead loads.

Table 7.1 Core wall—vertical loads

Item	Dead (kN)	Imposed (kN)
Walls and columns:		
braced core	2989	
other walls	2090	
Office roof	482	145

Item	Dead (kN)	Imposed (kN)
Core roof	134	41
Machine floor	215	202
Office floor×19	10984	6407
Core floor×19	3065	2554
Total	19959	9349

(a)  
Location of building

The building is located in a city in NE England on a redevelopment site, and stands clear in its own grounds, surrounded by gardens and car park. The site is 10 Km from the sea and 75 m above sea level. The building faces west.

(b)  
Building dimensions

The height is 87 m to parapet; the plan is octagonal 36 m×36 m, corner angle 135° (Figure 7.17).

(c)  
Building data (Section 1.6 and 1.7 of code)

Building type: framed with structural walls around lift; factor  $K_b=1$  (Table 1).

Reference height  $H_r=H=87$  m=effective height.

Ground roughness: town, clear of obstruction.

Dynamic augmentation factor  $C_f=0.08$  (Figure 3 in code).

(d)  
Wind speeds (Section 2.2 of code)

Basic wind speed  $V_b=25$  m/s (Figure 6)    Site wind speed  $V_s=V_b S_a S_d S_s S_p$     Altitude factor  $S_a=1+0.001\Delta_s=1.075$  ( $\Delta_s=75$  m)    Direction factor  $S_d=0.99$  (Table 3),  $\varphi=270^\circ$  west    Seasonal factor  $S_s=1.0$  (permanent building)    probability factor  $S_p=1.0$      $V_s=1.075 \times 0.99 \times 1.0 \times 1.0 \times 25 = 26.6$  m/s

Effective wind speed  $V_e=V_s S_b$  where  $S_b$  is the terrain and building factor.

The building is divided into a number of parts as set out in Figure 11 in the code in order to assess the value of  $S_b$ . The four divisions adopted for the building are shown in Figure 7.17. Factors  $S_b$  taken from Table 4 are listed in Table 7.2. These depend on the top height of each part.

(e)  
Wind loads (Section 2.1. of code)

$$\text{Dynamic pressure } q_s = 0.613 V_e^2 \text{ N/m}^2$$

values of  $q_s$  for the various building divisions are given in Table 7.2.

**Table 7.2** Wind load calculations

Building part	Reference height (m)	Terrain and building factor $S_b$	Effective wind speed $V_e=V_s S_b$ (m/s)	Dynamic pressure $q_s=0.613 V_e^2/10^3$ (kN/m <sup>2</sup> )	External surface pressure $p_e=q_s C_{pe} C_a$ (kN/m <sup>2</sup> )
1	87	2.1	55.9	1.92	1.73
2	83	2.09	55.6	1.9	1.7
3	47	2.05	54.5	1.82	1.64
4	36	1.98	52.7	1.7	1.53

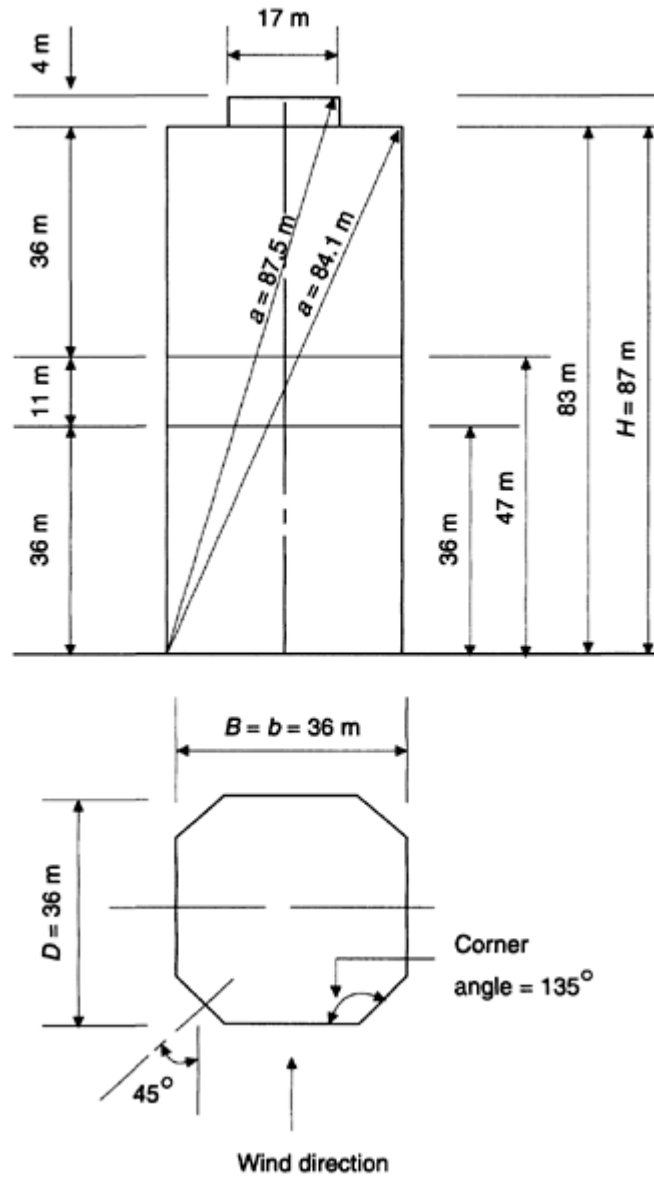

Fig. 7.17 Building dimensions (to top of parapet and outside of building).

Table 7.2 continued

Building part	Area of building part A (m <sup>2</sup> )	Overall load = 0.918 p <sub>e</sub> A (kN)	Lever arm (m)	Base moment (kN/m)
1	68	108	85	9180
2	1296	2023	65	131495
3	396	596	41.5	24734
4	1296	1820	18	32760
Total		4547		198769

The external surface pressure is

$$p_e = q_s C_{pe} C_a$$

where  $C_{pe}$  is the external pressure coefficient for the building surface (Table 5)—for  $D/H=36/87 < 1$ ,

$$C_{pe} = +0.8 \text{ (windward face)} \quad -0.3 \text{ (leeward face)} \quad = 1.1 \text{ (total)}$$

and  $C_a$  is the size effect factor (Figure 4). This depends on the diagonal dimension  $a$  (Figure 5 in the code and Figure 7.15).

For  $a=87.4$  m for a town site 10 km from the sea and  $H_e > 5$  m,  $C_a=0.82$ . Therefore

$$P_e = (1.1 \times 0.82) q_s = 0.9 q_s$$

Values of  $p_e$  are shown in [Table 7.2](#).

$$\text{Net surface load } P = pA$$

where  $p$  is the net pressure across the surface and  $A$  is the loaded area.

The overall load is found from  $P = 0.85(\sum P_{\text{front}} - \sum P_{\text{rear}})(1 + C_{\square})$  where  $C_{\square}$  is the dynamic augmentation factor ((c) above).

$$P = 0.85 \times 1.08 \sum P_{\text{overall}} = 0.918 \sum P_{\text{overall}}$$

(f)

*Polygonal building (Figure 7.17)*

Referring to Clause 3.3.1.2, from Table 27 the suction coefficients for zone A (Figure 31) can be reduced by 0.4. The corner angle is  $135^\circ$  and the adjacent upward face is  $21 \text{ m} > b/5 = 7.2 \text{ m}$ . The external pressure coefficients from Table 26 could be used. However, for simplicity the building will be taken as square and coefficients from the Standard Method will be used, giving a conservative result.

(g)

*Wind load calculations*

From the code data given above, the calculations for the wind loads are set out in [Table 7.2](#). These give the characteristic wind loads and moments at the base of the braced bay.

### 7.5.7

#### Stability, foundations and bracing

(a)

*Stability*

The load factors  $\alpha_f$  are:

- for dead load resisting overturning—1.0;
- for wind load—1.4.

The overturning moment is

$$1.4 \times 198769 = 278277 \text{ kNm}$$

The stabilizing moment about the compression leg of bracing is

$$2 \times 19959 \times 4.5 = 179631 \text{ kNm}$$

HD bolts must resist a moment of 98646 kNm. The bolt tension is

$$98646 / (2 \times 9) = 5480 \text{ kN}$$

Use bolts Grade 8.8, strength 450 N/mm<sup>2</sup> with 12 bolts per leg. The tensile area is

$$5480 \times 10^3 / 12 \times 450 = 1014 \text{ mm}^2$$

Provide 1242 mm dia. bolts, tensile area 1120 mm<sup>2</sup>.

Under full load with load factor 1.2, the uplift conditions are much less severe.

(b)

*Foundations*

The foundations could consist of a thick capping slab under the core supported on say, 12 cylinder piles depending on ground conditions. The two core walls at right angles to those considered would then assist in stabilizing the building. Pits for the lifts would be provided in the centre of the core slab. The outer columns could be supported on separate piled foundations. All foundations are tied together by the ground floor slab.

(c)

*Bracing (Figure 7.9)*

Only the section for the bottom bracing member is established. The length of the member is 11.4 m.

From Table 7.2

Wind shear=4547 kN

Tension=4547×11.4/2×9=2880 kN

Provide two channels with four bolt holes per channel. Net tensile area required using Grade 50 steel (Clause 3.33 of BS 5950):

$$A_{\text{net}}=2880 \times 10 / (1.1 \times 355 \times 2) = 36.9 \text{ cm}^2$$

Try 305×89[, with  $A=53.1 \text{ cm}^2$ ,  $T=13.7 \text{ mm}$ ,  $t=10.2 \text{ mm}$ ,  $p_y=355 \text{ N/mm}^2$ , and 22 mm dia. Grade 8.8 bolts, single shear value 114 kN. Then

$$A_{\text{net}}=53.1 - 2 \times 24(13.7 + 10.2) / 102 = 41.6 \text{ cm}^2$$

This is satisfactory.

The number of bolts required is  $2880/114=26$  for the two channels.

# CHAPTER 8

## Wide-span buildings

### 8.1 TYPES AND CHARACTERISTICS

Wide-span buildings may be classified into the following types:

1. One-way-spanning buildings—
  - truss or lattice girder/stanchion frames
  - portals and arches
  - cable or tie stayed lattice girder roof;
2. Combination portal or cable-stayed spine frame with lateral lattice girders;
3. Two-way-spanning trusses, Vierendeel girders or space deck systems;
4. Domes springing from circular or polygonal bases;
5. One-way-spanning cable girder and two-way-spanning cable net roofs.
6. Air-supported roofs.

Selected wide-span roof systems are shown in [Figure 8.1](#). The simplest wide-span structure is the flat or sloping roof truss or lattice girder/ stanchion frame. Portal frames and arches have been designed to span widths over 60 m. The older sawtooth roof designed to take advantage of natural lighting was once a common type of structure ([Figures 1.2 and 1.4](#)).

Various types of spine-supported buildings utilizing portals or cable/ tie-stayed frames have been constructed ([Figures 8.1 and 8.2](#)). A preliminary design is given for one system ([section 8.2](#)).

Much effort has been expended on the development of the two-way spanning space deck. This system provides a rigid three-dimensional flat roof structure capable of spanning a large distance with a small construction depth. The small depth reduces costs, while the exposed framing forms a pleasing structure. Commercial space deck systems are described. A preliminary design for a space deck is given.

The large framed dome is one of the most spectacular structures. Domes are constructed to cover sports arenas, auditoria, exhibition pavilions, churches etc. The masonry dome shell is an ancient structural form.

The cable girder and cable net roof with appropriate supporting structure are architectural forms in great demand for sports and exhibition buildings. Very large spans have been covered with air-supported, cable-stiffened membranes. These structures are outside the scope of the book.

One further modern development, the retractable roof structure, is discussed. Such structures, for sports arenas, become attractive where disruption due to adverse weather causes heavy financial losses. Some outline proposals are given for a football stadium with retractable roof.



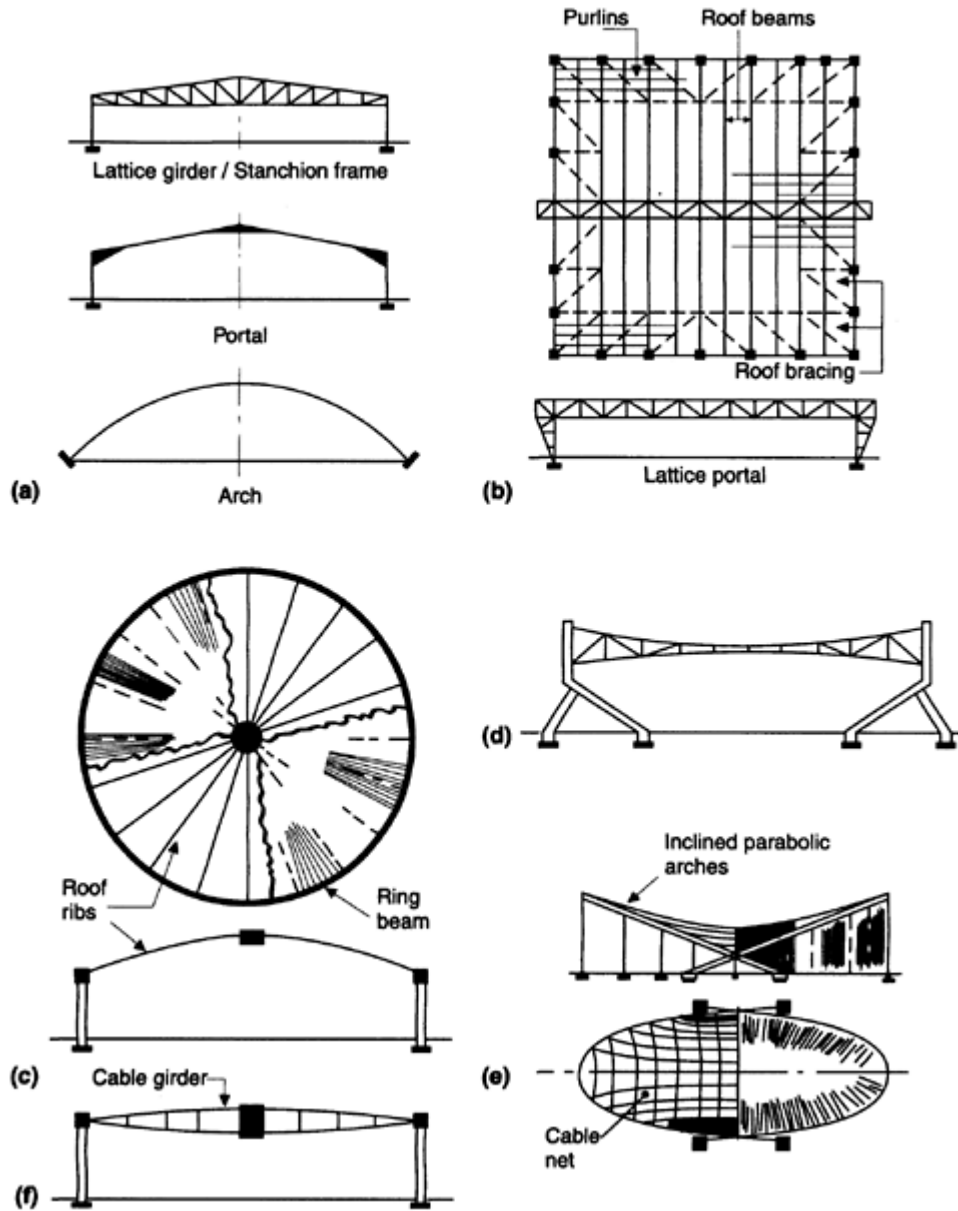

Fig. 8.1 Roof systems for wide-span buildings: (a) one-way spanning systems; (b) spine portal/roof beams; (c) dome roof; (d) one-way cable girder; (e) cable net roof; (f) cable roof, circular building.

8.2

TIE-STAYED ROOF—PRELIMINARY DESIGN

8.2.1

Specification

Make a preliminary design for a wide span roof with a tie-stayed spine support structure as shown in Figure 8.2. The roof construction is to consist of steel decking supported on purlins carried on lattice girders. The covering is three layers of felt on insulation board. The total dead load of decking and girders is taken as 1.0 kN/m<sup>2</sup> and of the spine girder 5 kN/m. The imposed load is 0.75 kN/m<sup>2</sup>. The steel is Grade 50 for the lattice girders and columns and Grade 55 for the stays.

Preliminary designs are to be made for:

- roof lattice girders;
- spine girder;
- front and back stays and column tie;

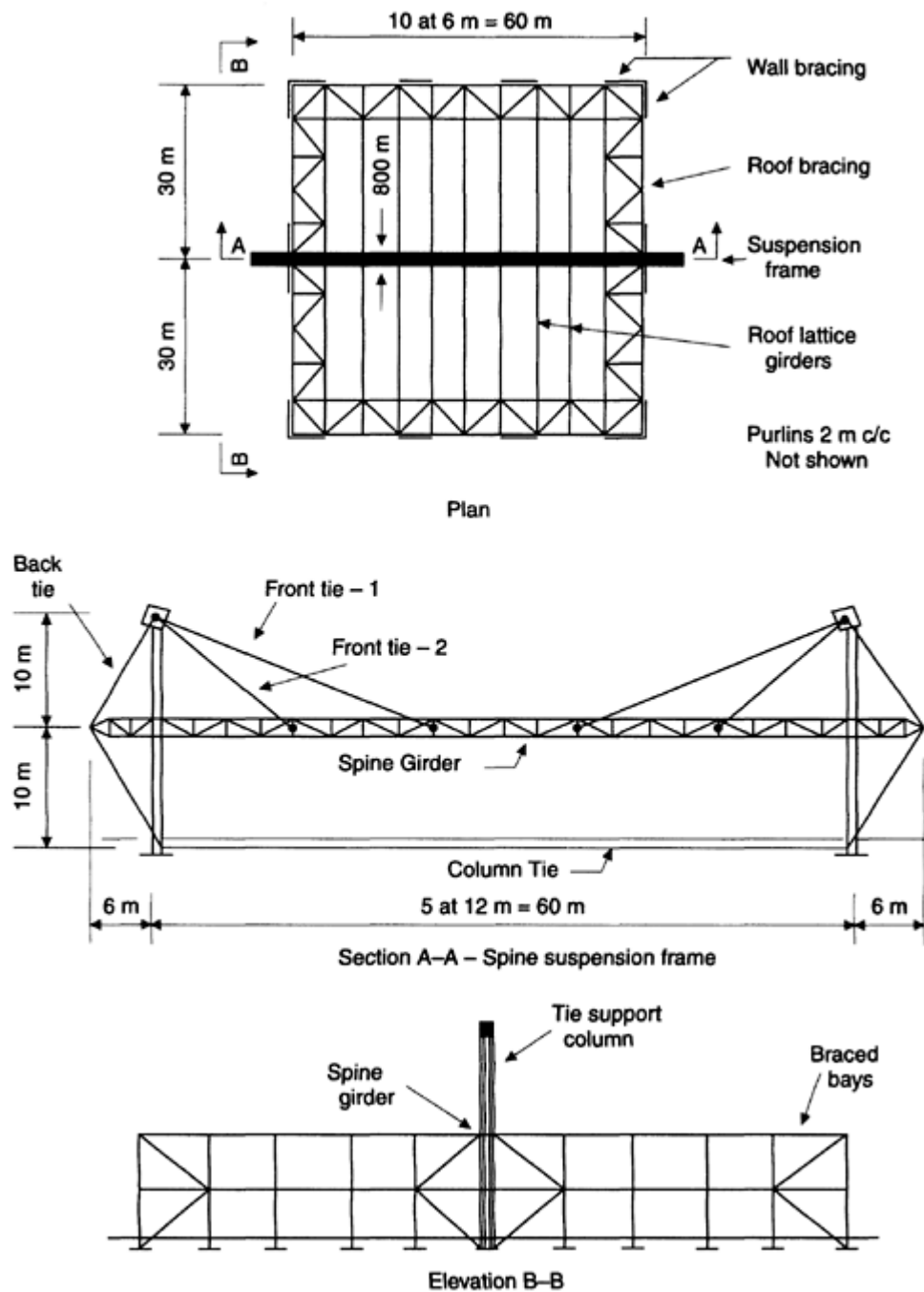

Fig. 8.2 Roof and spine suspension frame.

- spine frame column.

The design for stability and wind load is discussed.

The analysis carried out does not take into account the sinking supports of the girder. Secondary analysis tends to show that the girder section is satisfactory.

The aim of the analysis is to give member sections for a rigorous computer analysis.

Asymmetrical load cases should also be considered.

8.2.2

Preliminary design

$$\text{Design load}=(1.4 \times 1.0)+(1.6 \times 0.75)=2.6 \text{ kN/m}^2$$

(a)

Roof lattice girders (Figure 8.3(a))

The span is 29.6 m, depth is 1.5 m and spacing 6 m. Thus

$$\text{Load}=2.6 \times 29.6 \times 6=462 \text{ kN}$$

$$\text{Chord force}=462 \times 29.6 / (8 \times 1.5)=1140 \text{ kN}$$

The top chord is supported at 2 m centres by purlins (Steel Construction Institute, 1987). Select 120×120×8 SHS, with  $P_c=1160 \text{ kN}$ ,  $P_t=1260 \text{ kN}$ . Reduce to 120×120×6.3 RHS at quarter points. For the web at support,

$$F=2.5 \times 231 / 1.5=385 \text{ kN}$$

Use 90×90×5 SHS on outer quarter lengths. Reduce to 70×70×3.6 SHS over centre half.

(b)

Spine structure—analysis

The loads on one-half of the spine girder are shown in Figure 8.3(b).

$$\text{Self-weight}=1.4 \times 5=7 \text{ kN/m}$$

The fixed end moments are

$$\text{Span AB: } M_{BA}^F = 7 \times 6^2 / 8 = 31.5 \text{ kNm}$$

$$\text{Spans BC, CD, DE: } M^F = \frac{462 \times 12}{8} + \frac{7 \times 12^2}{12} = 777 \text{ kNm}$$

The distribution factors are

$$\text{DF}_{BA} : \text{DF}_{BC}, \text{ from } \frac{0.75}{6} / \left( \frac{0.75}{6} + \frac{1}{12} \right) = 0.60 : 0.40$$

$$\text{DF}_{CB} : \text{DF}_{CD}, \text{ and } \text{DF}_{DC} : \text{DF}_{DE} = 0.5 : 0.5$$

Results of the moment distribution are shown in the figure, from which the spine beam shears and reactions are calculated.

The forces in the ties, column and column tie are shown in Figure 8.4. The self-weight of the column is taken to be 40 kN/m. The forces are found using statics. The tie forces are slightly changed by the end reaction at A in the spine girder. This is neglected.

(c)

Spine girder design

The maximum design conditions are

$$M=850 \text{ kNm}, F=6909 \text{ kN}, V=259 \text{ kN}$$

The trial section shown in Figure 8.5(a) consists of 4 Wo. 200×200×12.5 SHS chords, with

$$A=4 \times 93=372 \text{ cm}^2 \quad I_X=(4 \times 93 \times 75)^2+(4 \times 5420) \\ =2110580 \text{ cm}^4 \quad S=4 \times 93 \times 75=27900 \text{ cm}^3 r_X=(2110580/372)^{0.5}=75.4 \text{ cm}=7.63 \text{ cm for SHS}$$

Assume that the effective length for buckling about the XX axis is 0.9 times the total girder length of 60 m:

$$\lambda_X=0.9 \times 6000 / 75.4=71.6$$

For one chord,

$$\lambda_Y=600 \times 0.9 / 7.63=70.8 \quad p_c=265.2 \text{ N/mm}^2 \text{ (Table 27(a))} \quad P_c=265.2 \times 372 / 10=9865 \text{ kN} \quad M_c=27900 \times 355 / 10^3=9905 \text{ kNm}$$

$$\text{Combined: } (7306/9865)+(850/9905)=0.83$$

For the web member,

$$\lambda=0.9 \times 3.55=3.19 \text{ m}$$

Select 90×95×5 RHS (Steel Construction Institute, 1987). Adopt this section throughout the girder length.

For Cross members use 80×80×5 RHS.

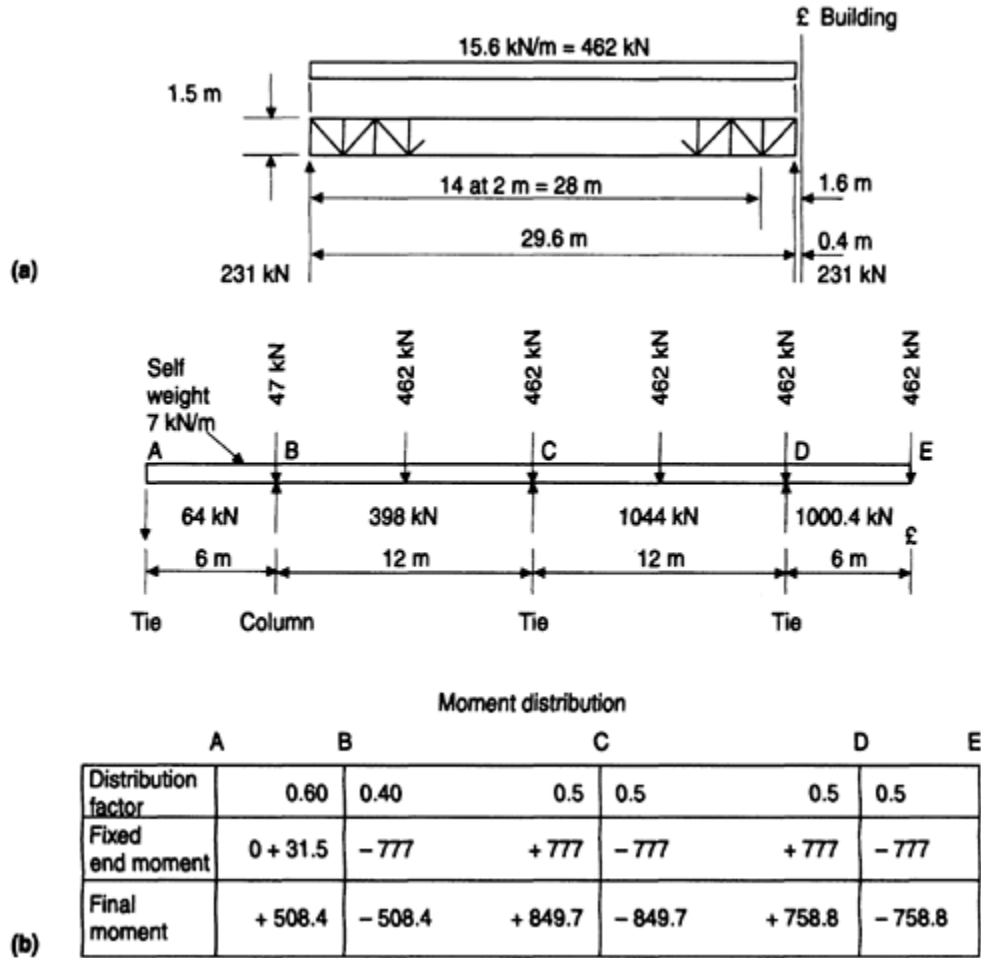

Fig. 8.3 Roof and spine girder analysis: (a) roof lattice girder; (b) spine girder.

(d)  
Column design

The maximum design conditions are

Top length,  $F=8797$  kN

Bottom length,  $F=9839$  kN

The trial section is a 600 mm×600 mm box ×35 mm plate (Figure 8.5(b)), with  $P_y=345$  N/mm<sup>2</sup> and

$b/T=530/35=15.1 < (275/345)^{0.5} \times 35=31.2$   
(compact)  $A=791$  cm<sup>2</sup>,  $r_x=23.1$  cm

$\lambda=2.5 \times 1000/23.1=108.$   
2 (Table 10, BS 5950)

$p_c=136.3$  N/mm<sup>2</sup>  
(Table 27(b))

$P_c=10779$  kN

Refer to stability assessment in section 8.2.3.

(e)  
Front tie 1 (Figures 8.4(a) and 8.5(c))

The stay material is Grade 55 Steel.

Tie force=2600 kN+self-weight□30 kN

Provide four flats, with  $T=658$  kN per flat. Allow for splices—4 No. 20 mm dia. Grade 8.8 bolts, double shear capacity 188 kN. Try flat 150 mm×15 mm with 2 No. 22 mm dia. holes:

Capacity  $P_t=(150 \times 15 - 2 \times 15 \times 22)450/10^3=716$  kN

The tie is connected by pin to the centre vertical of the spine girder. For Grade 8.8 material, shear strength  $P_s=375$  N/mm<sup>2</sup>.

Pin diameter= $(658 \times 10^3 \times 4/375\pi)^{0.5}=47.2$  mm

Provide 50 mm dia. pin.

For post plate use Grade 50 steel,  $P_y=345$  N/mm<sup>2</sup>.

Design for bearing (Clause 6.5.3.3 of BS 5950):

$t=658 \times 10^3/1.2 \times 345 \times 50=31.8$  mm

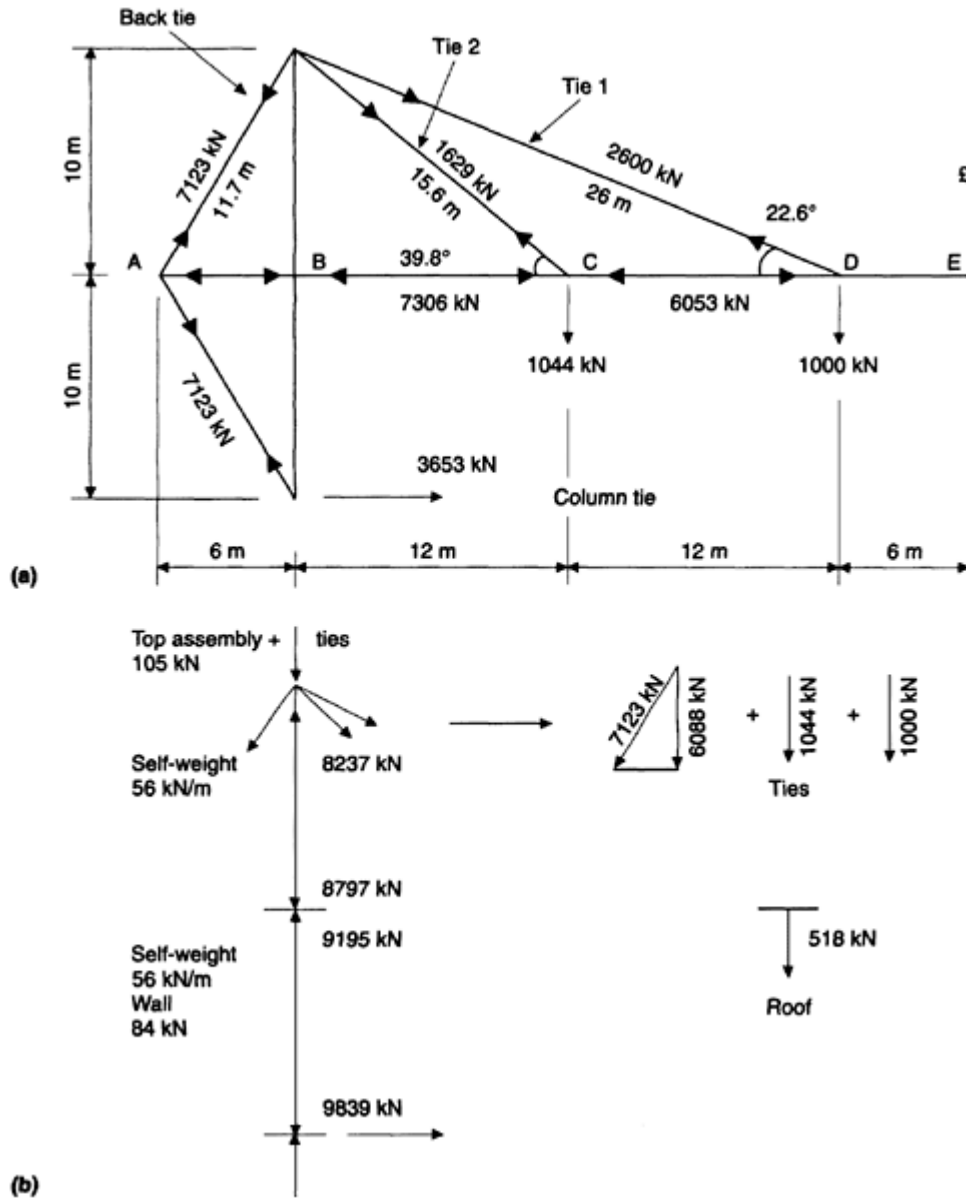

Fig. 8.4 Forces: (a) stays and column tie; (b) column.

Provide 40 mm thickness—use 20 mm doubler plate as shown in Figure 8.4(c).

For tie plate at pin use Grade 55 steel,  $P_y=400 \text{ N/mm}^2$ . Thickness for bearing;  
 $t=658 \times 10^3 / 1.2 \times 400 \times 50 = 27.4 \text{ mm}$

Provide 30 mm plate and splice to 15 mm plate. The tie end can be designed to conform with Figure 13 of BS 5950.

The vertical post section is shown in Figure 8.5(c).

$$I_x = 21560 \text{ cm}^4 \text{ (gross)} \qquad A = 184 \text{ cm}^2, S = 2425 \text{ cm}^3 \text{ (at centre)}$$

The pin load causes bending and axial load in the post and bending in the chords. Consider the part frame in the figure. Neglect diagonal members.

For the chords (200×200×12.5 SHS),

$$I/L = 5420 / 300 = 18$$

For the post (300×200 box),

$$I/L = 21560 / 150 = 144$$

The distribution factors are

$$\text{Chord : Post : Chord} = \frac{18 : 144 : 18}{180} = 0.1 : 0.8 : 0.1$$

The fixed end moment is

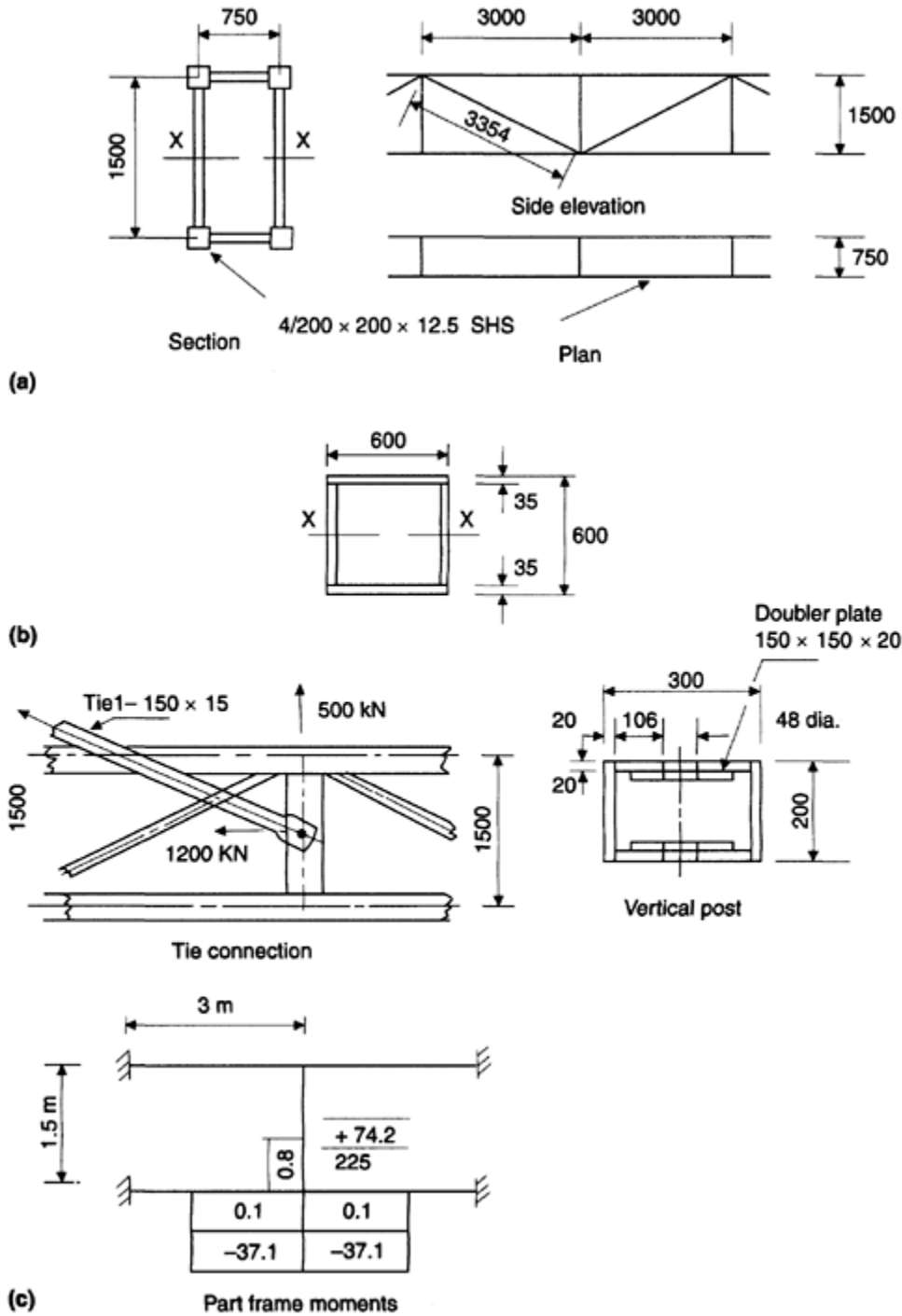

Fig. 8.5 Suspension frame: (a) spine lattice girder; (b) column; (c) tie connection to post.

$$1200 \times 1.5 / 8 = 225 \text{ kNm}$$

After distribution the final moments are

Chord  $M = 37.1 \text{ kNm}$

Post-support  $M = 74.2 \text{ kNm}$

Centre  $M = 375.8 \text{ kNm}$

For the chord the actions at D from Figures 8.3(b) and 8.4(a) are

$F = 6053 \text{ kN}$

$M_{\text{girder}} = 758.8 \text{ kNm}$

$M_{\text{chord}} = 22.5 \text{ kNm}$

$M_C = 231 \text{ kNm}$

Combined ((c) above):

$$\frac{6053}{9865} + \frac{758.8}{9905} + \frac{37.1}{231} = 0.85$$

For the post,

$$F=500 \text{ kN}, M=375.8 \text{ kNm}$$

$$M_C=837 \text{ kNm}, P_C=6348 \text{ kN}$$

$$\text{Combined}=0.53$$

The post sideplate thicknesses are determined by the bearing of the pin.

(f)

*Front tie 2*

Tie force  $T=1629 \text{ kN}+20 \text{ kN}$  factored self-weight

Use 4 No. 120 mm×15 mm flats for 412 kN/flat.

Splice=3 No. 20 mm dia. Grade 8.8 bolts

Pin diameter=40 mm

Tie end thickness for bearing=22 mm

Column plate thickness for bearing=25 mm

(g)

*Back ties*

Tie force  $T=7123 \text{ kN}+40 \text{ kN}$  factored self-weight

Use 4 No. 260 mm×25 mm flats for 1790 kN/flat.

Splice=6 No. 27 mm dia. Grade 8.8 bolts

Pin diameter=80 mm

Tie end thickness for bearing=45 mm

Column plate thickness for bearing=55 mm

(h)

*Column ties*

Tie force  $T=3653 \text{ kN}$

Use 2 No. 275 mm×25 mm flats.

For bolts to column plates, use 9 No. 30 mm dia. Grade 8.8 m single shear for each flat.

(i)

*Tie connection arrangements*

The connection arrangements for the stays are shown in [Figure 8.6](#).

### 8.2.3

#### Stability and wind load

The spine column must be restrained laterally and longitudinally in position at roof level. Restraint is provided by the roof and wall bracing systems. These systems, shown in [Figure 8.7\(d\)](#) also resist wind loads on the building.

(a)

*Column restraint force*

Refer to Clauses 4.7.3 and 4.7.12 of BS 5950. Clause 4.7.12 states that the restraint system must be capable of resisting 2.5% of the factored load in the column.

The restraint loads are as follows.

#### (i) Dead and imposed load case

Factored column load=9195 kN ([Figure 8.4\(b\)](#))

Restraint lateral load= $0.025 \times 9195 = 230 \text{ kN}$

#### (ii) Dead, imposed and wind load case

The frame is reanalysed to give

Dead load=4002 kN Imposed load=2244 kN Factored column load= $1.2(4002+2244)=7495 \text{ kN}$  Restraint lateral load=187.4 kN

This load is to be added to the factored wind load.

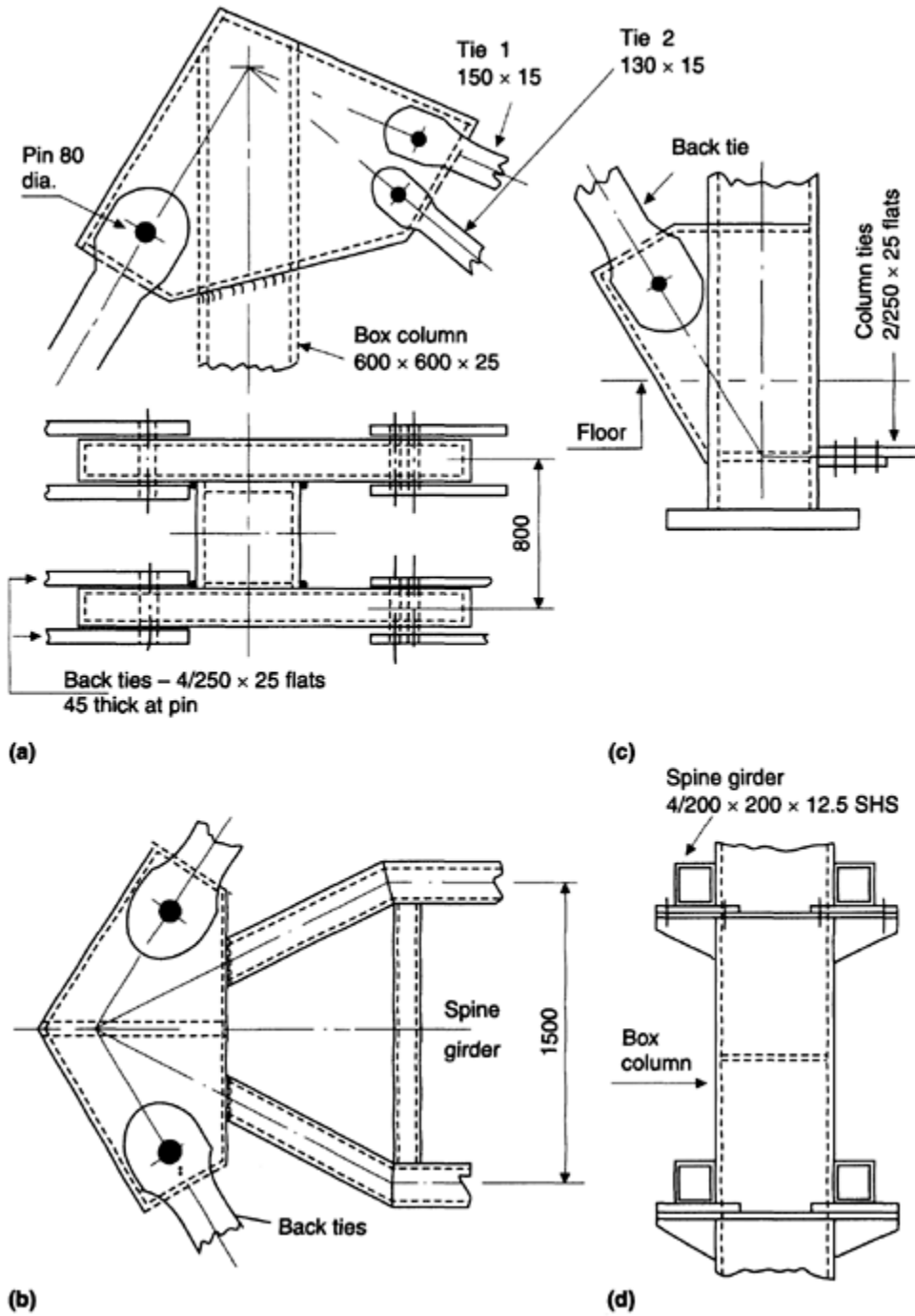

**Fig. 8.6** Tie connections: (a) top, stays-column; (b) back, stays-spine girder; (c) base, stays-column tie-column; (d) spine girder-column. (Not all stiffeners are shown.)

(b)  
Wind load

The following components of wind load must be calculated for wind blowing in the transverse and parallel directions.

- wind on the building face;
- wind on the suspension frame and column;
- frictional drag on the roof and walls.

The various components of wind load are shown in [Figure 8.7\(b\)](#).



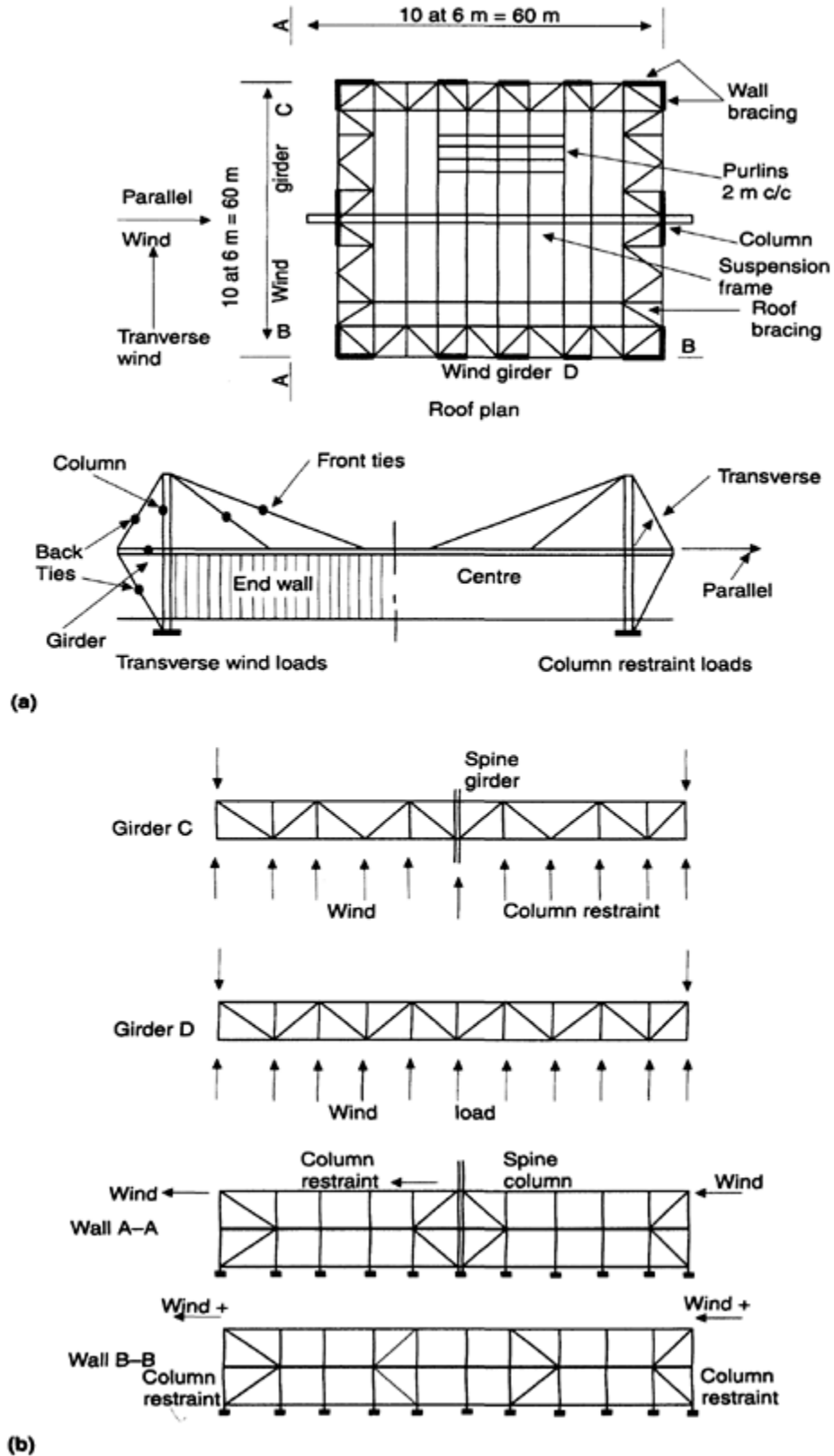
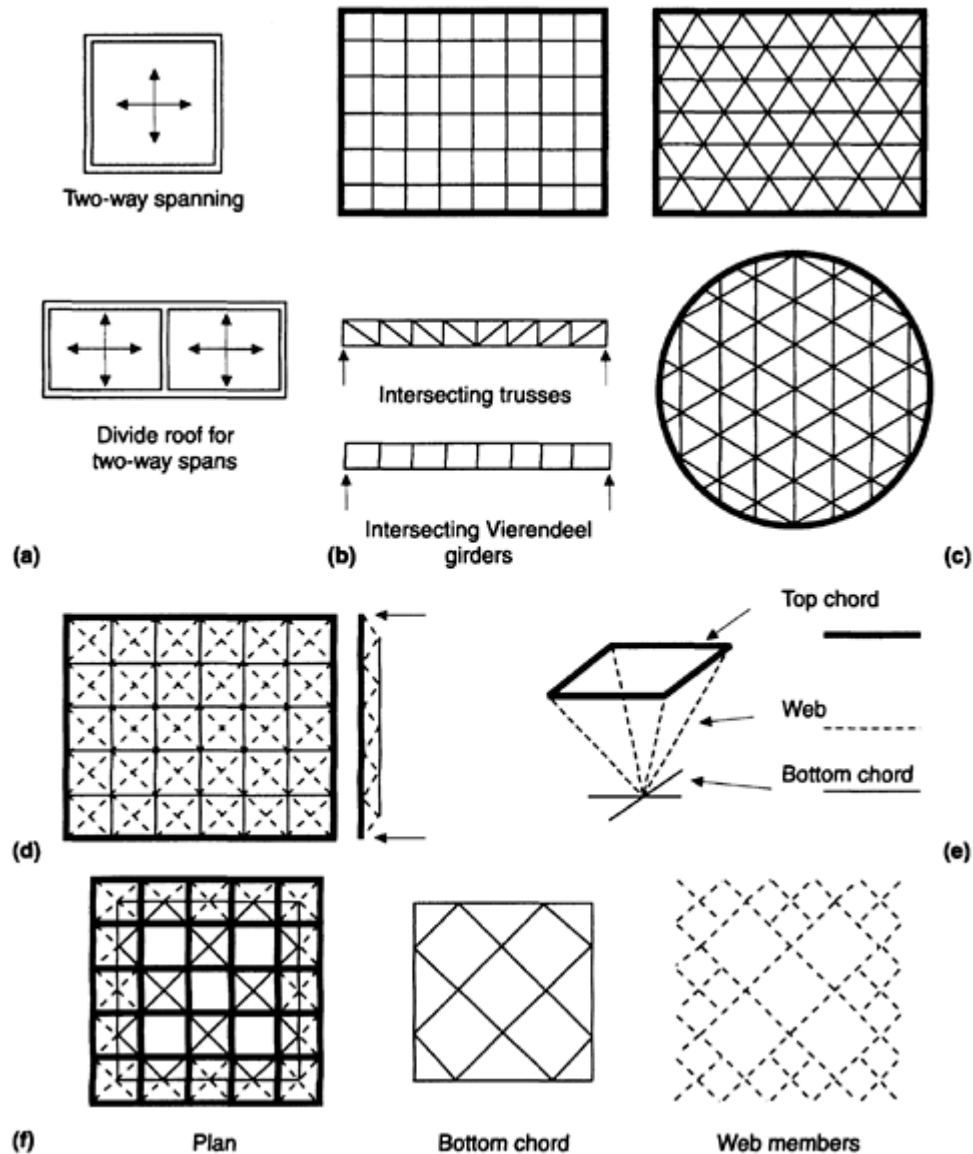

Fig. 8.7 Wind and column restraint loads: (a) roof and wall bracing systems; (b) load components.

### 8.3 SPACE DECKS

#### 8.3.1 Two-way spanning roofs

If the length of the area to be roofed is more than twice the breadth, it is more economical to span one way. If the area is



**Fig. 8.8** Wide-span roofs: (a) two-way spanning; (b) two-way grids; (c) three-way grids; (d) space deck with cornice edge; (e) basic pyramid unit; (f) square on larger square set diagonally, cornice edge.

nearer square, the more economical solution, theoretically, is to span two ways. A rectangular area can be divided into square or near-square areas with lattice girders and then two-way-spanning structures can be installed in the subdivided roof (Figure 8.8(a)).

The two-way-spanning grid may be a single or double layer. The single-layer grid of intersecting rigid jointed members is expensive to make and more easily constructed in reinforced concrete than steel.

The double-layer grid can be constructed in a number of ways. Lattice or Vierendeel girders intersecting at right angles can be used to form two-way grids where the bottom chord lies below the top chord (Figure 8.8(b)). The roof is divided into squares which can be covered with plastic roof units. Three-way grids, where the surface is divided into equilateral triangles, are shown in Figure 8.8(c).

Double-layer grids, where the bottom chords do not lie in the same vertical plane or in some cases do not have the same geometrical pattern as the top chords, are termed space grids or decks.

### 8.3.2 Space decks

The basic form of space deck shown in Figure 8.8(d) is square on square offset with cornice or mansard edge, where the top and bottom chords form squares of equal area. The basic unit is the inverted square-based pyramid shown in Figure 8.8(e). Other variations are possible such as that shown in Figure 8.8(f), termed square on larger square set diagonally.

A great effort in inventiveness, research and testing has gone into perfecting systems for constructing space decks. Two main construction methods are used:

- division into basic pyramid units;
- joint systems to connect deck members.

These systems are discussed below. Triangular trusses have also been used as the shop fabricated unit.

#### (a) *Basic pyramid unit*

As stated above, the inverted pyramid forms the basic unit of the square on square space deck. The units are prefabricated with top chords as angles or channels, tubular section web members and bottom chords consisting of high tensile bars with screwed ends. Top chord lengths vary from 1.2 to 2.5 m, while depths vary from 0.8 to 1.5 m. The pyramids conveniently stack together for transport.

The grid is assembled by bolting the top chords together and connecting the bottom chords through the screwed joints. The grid is constructed at ground level and hoisted into position as a complete structure.

#### (b) *Joint system*

The joint system gives greater flexibility in space deck construction than the fixed component system. The joint connects eight members coming from various directions in space to meet at a point. The finished structure is assembled from straight members, usually hollow sections and joints.

Three commercial joint systems are briefly described below.

- Nodus System—this was developed by the British Steel Corporation and is now manufactured and marketed by Space Deck Limited. It consists of two half castings clamped together by a bolt. The chords lock into grooves in the castings, while the webs have forked ends for pin connections to the lugs on the castings.
- Mero Joint System—this consists of cast steel balls into which the ends of members are screwed through a special end connector. The Mero balls are made in a range of sizes to accommodate different member sizes and web member inclinations. There is no eccentricity at the joint.
- Nippon Steel Corporation NS Space Truss System—the joint consists of a steel bowl node to which the space deck members are connected by special bolted joints. There is no eccentricity at the joint.

Very large and heavy space deck systems have been constructed for aircraft hangers, wide conference halls etc. These have heavy tubular or box members and site-welded joints.

### 8.3.3 Space deck analyses and design

Space decks are highly redundant and analysis is carried out using a space frame program. Joints are normally taken as pinned. The space deck dead load from the flat roof decking and self-weight of grid is greater than uplift due to wind. Only the dead and imposed load case need be considered.

The space deck can be considered as a plate supported on four sides to obtain member forces for preliminary design. British Steel Corporation Tubes Division (n.d.) gives approximate formulae for chord forces and reactions. These can be used to obtain sections for computer analysis.

For a square or rectangular grid only one-quarter of the frame need be considered in the analysis. Rotational and linear restraints are applied as required to members cut by the section planes. If members are sectioned lengthwise, one-half the properties are used in the analysis.

For a grid considered as pin jointed, member design is as follows.

- Top chord—design for axial compression and bending due to roof load applied through purlins or roof units. Effective length =  $0.9 \times$  member length.
- Bottom chord—design for axial tension and any bending from ceiling or service loads.
- Webs—design for tension or compression as applicable. Effective length =  $0.9 \times$  member length.

## 8.4

### PRELIMINARY DESIGN FOR A SPACE DECK

#### 8.4.1

##### Specification

A preliminary design is made for a space deck roof for a building 60 m square. The roof construction consists of steel decking supported on the space frame and purlins, insulation board and three layers of felt. The total dead load including an allowance of  $0.3 \text{ kN/m}^2$  for the space deck is  $1.0 \text{ kN/m}^2$ . The imposed load is  $0.75 \text{ kN/m}^2$ . The deck steel is Grade 50.

#### 8.4.2

##### Arrangement of space deck

The arrangement for the space deck is shown in Figure 8.9(a). The deck is square on square offset with mansard edge. The square module is  $5 \text{ m} \times 5 \text{ m}$  and the deck depth is  $3 \text{ m}$ . The deck is supported around the perimeter on  $8 \text{ m}$ -high columns located at the bottom chord node points. The side walls are braced to resist wind loading.

#### 8.4.3

##### Approximate analysis and design

An approximate analysis as a plate is made to obtain the maximum forces in the space deck members from which the sizes to be used in the final analysis can be determined.

The approximate analysis is from British Steel Corporation Tubes Division (n.d.).

$$\text{Design load} = 1.4 \times 1.0 + 1.6 \times 0.75 = 2.6 \text{ kN/m}^2$$

The load arrangement on the top chord members is shown in Figure 8.9(b) where the purlin applies a point load and the decking a uniform load on the top chord members.

Total load on the deck $T=2.6 \times 60 \times 60 = 9360 \text{ kN}$	Deck module $n=5 \text{ m}$	Depth of deck $D=3 \text{ m}$	Chord force factor $F=0.08$	Maximum Chord force = $9360 \times 5 \times 0.08 / 3 = 1248 \text{ kN}$	Maximum reaction = $9360 \times 5 \times 0.08 / 8 = 500 \text{ kN}$
--	-----------------------------	-------------------------------	-----------------------------	---	---

The initial design of the grid members is as follows.

(a)

*Bottom chord*

$$F = 1248 \text{ kN}$$

Try  $150 \times 150 \times 6.3 \text{ RHS}$ , with  $P_t = 1280 \text{ kN}$  or  $168.3 \times 8 \text{ CHS}$ ,  $P_t = 1430 \text{ kN}$ .

(b)

*Top chord*

$$F = 1248 \text{ kN}$$

$$M = 2.6 \times 2.5 \times 5^2 / 4 = 40.6 \text{ kNm}$$

Try  $200 \times 200 \times 8 \text{ RHS}$ , with  $r = 7.83 \text{ cm}$ ,  $A = 61.1 \text{ cm}^2$ ,  $S = 439 \text{ cm}^3$ .

$$\lambda = 0.9 \times 5000 / 7.83 = 57.5$$

$$p_c = 304 \text{ N/mm}^2 \text{ (Table 27(a))}$$

$$M_c = 439 \times 355 / 10^3 = 155.8 \text{ kNm}$$

Combined:

$$(1248 \times 10 / 304 \times 61.1) + (40.6 / 155.8) = 0.93$$

An alternative section is  $219.1 \times 10 \text{ CHS}$ .

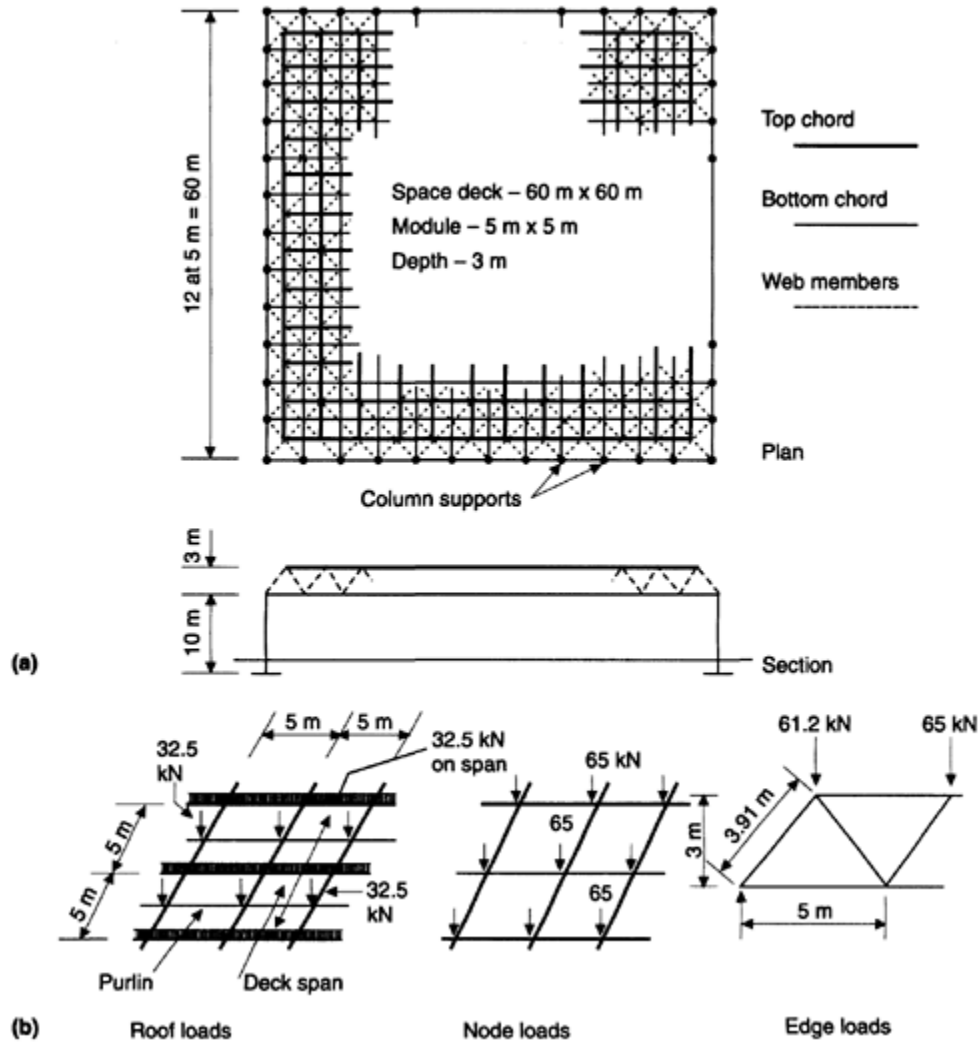

Fig. 8.9 Space deck—square on square offset, mansard edge.

(c)

Web members

Length =  $(2 \times 2.5^2 + 3^2) \times 0.5 = 4.64$  m  
 Select 139.7 × 5 CHS, with  $P_C = 444$  kN.

Load =  $500 \times 4.64 / (2 \times 3) = 386$  kN

Effective length =  $0.9 \times 4.64 = 4.18$  m

### 8.4.4 Computer analysis

The computer analysis is carried out for a pin-jointed frame for dead and imposed loads only. Wind uplift is less than the dead load. Due to symmetry, only one-quarter of the frame need be considered for analysis. The data for the space frame program are discussed and set out below.

(a)

Joint coordinates

The quarter frame and joint numbering are shown in Figure 8.10. The joint coordinates and member connection can be taken off the figure and member numbers assigned.

Number of joints = 97  
 The joints are taken as pinned.

Number of members = bottom chords (84) + top

Chords (72) + web (144) = 300

(b)  
*Member properties*

The properties of the various member types are taken from the approximate design. Section properties are reduced for the two outer modules of the top and bottom chords and for the inner 4.5 modules of the web, that is:

- top chord—outside lines 38–94 and 38–42;
- bottom chord—outside lines 31–87 and 31–35;
- web—outside lines 31–87 and 31–35.

One-half of the properties of the bottom chord members lying on the section planes are used in the analysis. The member properties are given in [Table 8.1](#).

(c)  
*Restraints*

The restraints at supports and where members are cut by section planes are listed in [Table 8.2](#).

The maximum member forces are given for the inner and outer modules as specified in [section 8.4.4\(b\)](#) ([Figure 8.9](#) and [Table 8.1](#)). The top chord moment due to the purlin load is 40.6 kNm in members carrying purlins ([Figure 8.9\(b\)](#) and [section 8.4.3\(b\)](#)). In members at right angles the moment is 20.8 kNm.

**Table 8.1** Member Properties for Analyses

Members	Section	Area (cm <sup>2</sup> )	Moment of inertia (cm <sup>4</sup> )		Torsion Constant <i>J</i>
			<i>I<sub>x</sub></i>	<i>I<sub>y</sub></i>	
Top Chord:					
Outer modules	180×180×6.3 RHS	43.6	2190	2190	3360
Inner modules	200×200×8 RHC	61.1	3740	3740	5770
Bottom Chord:					
Outer modules	139.7×8 CHS	33.1	720	720	1440
Inner modules	168.3×8 CHS	40.3	1300	1300	2590
Web:					
Outer modules	139.7×5 CHS	21.2	481	481	961
Inner modules	114.3×5 CHS	17.2	257	257	5140

**Table 8.2** Restraints

Joint No.	Restraint <sup>a</sup>
Supports:	
1, 2, 3, 4, 5, 6	LZ
15, 29, 43, 57, 71	LZ
7	LY, LZ, RX
85	LX, LZ, RY
Section plane X <sub>1</sub> –X <sub>1</sub> :	
14, 21, 28, ... 70, 77, 84	LY, RX
Section plane Y <sub>1</sub> –Y <sub>1</sub> :	
92, 86, 93, ... 90, 97, 91	LX, RY
Centre: 91	LX, LY, RX, RY, RZ

<sup>a</sup>L=linear restraint and direction axis; R=rotational restraint and axis about which it acts

(d)  
*Loading*

All loads are applied to the top chord nodes as follows ([Figures 8.9\(b\)](#) and [8.10](#)):

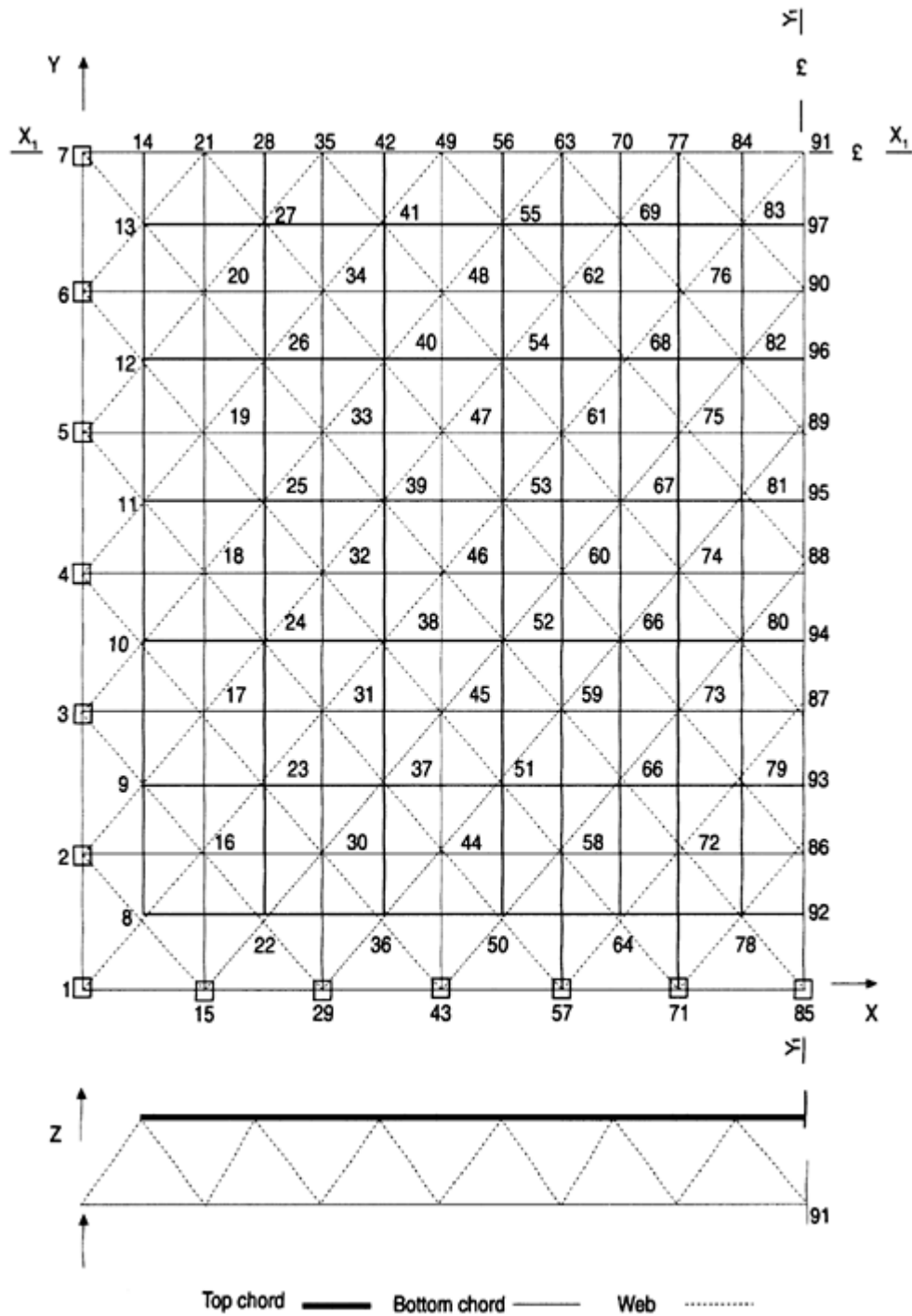

Fig. 8.10 One-quarter deck—joint members.

- node 8—

$$\text{Load} = [2.5^2 + (2.5 + 0.625)]3.91 \times 1.4/2 + (3.75^2 \times 1.2) = 42.8 \text{ kN}$$

- nodes 9, 10, 11, 12, 13, 22, 36, 50, 64, 78—  
 $\text{Load} = [(3.91 + 5)5 \times 1.4/2] + [(5 + 2.5)5 \times 1.2/2] = 53.7 \text{ kN}$

- nodes 23, 24, 25, 26, 27, 37, 38, 39, 40, 41, 51, 52, 53, 54, 55, 65, 66, 67, 68, 69, 79, 80, 81, 82, 83—

$$\text{Load}=2.6 \times 25=65 \text{ kN}$$

The maximum moment in top chord members is

$$M=32.5 \times 5/4=40.63 \text{ kNm}$$

The loads over supports are not listed.

#### 8.4.5 Computer results

The computer output for critical members in top and bottom chords and web members is given in Table 8.3.

#### 8.4.6 Member design

(a)

*Top chord—inner modules*

$$C=-1587 \text{ kN}, M=40.6 \text{ kNm}$$

Try  $200 \times 200 \times 10$  SHS, with  $r=7.74 \text{ cm}$ ,  $A=75.5 \text{ cm}^2$ ,  $S=536 \text{ cm}^3$ .

$$\lambda=0.9 \times 5000/77.4=58.1 \quad p_c=302.8 \text{ N/mm}^2 \quad P_c=302.8 \times 75.5/10=2286 \text{ kN} \quad M_c=355 \times 536/10^3=190.3 \text{ kNm}$$

$$\text{Combined: } (1587/2286)+(40.6/190.3)=0.9$$

This is satisfactory.

(b)

*Top chord—outer modules*

$$C=-936 \text{ kN}, M=40.6 \text{ kNm}$$

**Table 8.3** Computer results for critical members

<i>Location</i>	<i>Member</i>	<i>Force<sup>a</sup> (kN)</i>	<i>Maximum moment (kNm)<sup>b</sup></i>
Top chord:			
Inner modules	83–84	–1587	40.6
Outer modules	79–80	–936	40.6
Bottom chord:			
Inner modules	76–77	+1225	–
	90–91	+1126	–
Outer modules	17–33	+586	–
Web:			
Outer modules	7–13	–310	–
	13–21	+333	–
Inner modules	35–41	–211	–
	41–9	+197	–

<sup>a</sup>+ = Tension; – = compression. <sup>b</sup>Moments for top chord calculated by statics.

Select  $180 \times 180 \times 8$  SHS.

(c)

*Bottom chord—inner modules*

$$T=1225 \text{ kN}$$

Select section from capacity tables

Select  $168.3 \times 8$  CHS, with  $P_t=1430 \text{ kN}$  from capacity tables (Steel Construction Institute, 1987).



(d)  
*Bottom chord—outer modules*

$$T=586 \text{ kN}$$

Select 114.3×3 CHS, with  $P_t=611 \text{ kN}$

(e)  
*Web—outer modulus*

$$C=-310 \text{ kN}, T=333 \text{ kN}$$

$$\text{Effective length } l=4.64 \times 0.9=4.2 \text{ m}$$

Select 137.7×5 CHS, with  $P_c=470 \text{ kN}$  for  $l=4 \text{ m}$ ,  $P_t=753 \text{ kN}$ .

(f)  
*Web—inner modules*

$$C=-211 \text{ kN}, T=197 \text{ kN}$$

Select 114.3×5 CHS.

## 8.5 FRAMED DOMES

### 8.5.1 Types

Domes are most usually generated by rotating a plane curve, often a sector of a circle, about the vertical axis. Other curves, such as a parabola or ellipse, could be used, or the dome could be formed from intersecting cones. Again, domes are usually constructed on circular or regular polygonal bases where apexes touch the circumscribing circle. Other base shapes can be used.

From classical times masonry domes have been constructed. Another example is the Eskimo's igloo. The large-span skeletal or braced dome dates from the last century. Members may be curved or straight to meet at joints lying on the shell surface. Domes are doubly curved synclastic surfaces, that is the curvature is of the same sign in each direction.

Braced domes are classified according to the way in which the surface is framed. Many different patterns have been devised. The main types of spherical dome (Figure 8.11) are as follows.

(a)  
*Ribbed dome*

This dome consists of equally spaced radial ribs on arches supported by a compression ring at the top and a tension ring or separate bases at ground level. The ribs carry triangular loading and the dome can be designed as a series of two- or three-pinned arches.

(b)  
*Schwedler dome*

This consists of ribs or meridional members and parallel rings or hoops which support the ribs. The two member systems divide the surface into trapezoidal panels, which are braced diagonally to resist shear due to asymmetrical loading. The joints between ribs and rings may be made rigid as an alternative method of resisting shear. If the dome is loaded symmetrically and the joints are taken as pinned the structure is statically determinate. An analysis can also be based on spherical thin-shell theory.

(c)  
*Lattice or network dome*

In this type, parallel rings are spaced equidistantly. The annular spaces are then subdivided by triangular networks of bars. Members between any two adjacent rings are equal in length.

(d)  
*Lamella domes*

Two types, the curved and parallel lamella, are defined. In the curved type the surface is divided into diamond-shaped areas, while the parallel lamella type consists of stable triangular divisions. The world's two largest domes are of the parallel lamella type. The curved lamella type was a development for timber domes, where the timber cladding provided stability. Note that in the network dome the horizontal rings cover this requirement.

(e)  
*Grid dome*

This type of dome is formed by a two- or three-way intersecting grid of arcs. Where the arcs are great circles, the geodesic dome is one special case of the grid dome.

(f)  
*Geodesic dome*

This system was developed by Buckminster Fuller. Most geodesic dome construction is based on the icosahedron, the regular 20-sided solid whose apexes touch the surface of the circumscribing sphere. The dome is formed from part of the sphere. Each primary spherical triangle may be subdivided further to make the framing of large domes possible. The main advantage of this type of dome is that all members are of approximately equal length and the dome surface is subdivided into approximately equal areas.

### 8.5.2 Dome construction

(a)  
*Framing*

Dome framing may be single or double layer. Large domes must be double layer to prevent buckling. All types of members have been used. Hollow sections with welded joints are attractive where the steelwork is exposed. Members are usually straight between nodes. The dome must be broken down into suitable sections for shop fabrication. Lattice double-layer domes, can be assembled on site using bolted joints.

(b)  
*Proprietary jointing systems*

Domes systems using the Mero and Nippon NS Space Truss joints are available. The domes can be single or double layer. Network and geodesic systems are available.

(c)  
*Cladding*

Cladding causes problems because panel dimensions vary in most domes and twisted surface units are often needed. The systems used are:

- roof units, triangular or trapezoidal in shape, supported on the dome frame—These may be in transparent or translucent plastic or a double-skinned metal sandwich construction;
- timber decking on joists with metal sheet or roofing felt covering;
- steel decking on purlins and dome members with insulation board and roofing felt—This can only be used on flat surfaces.

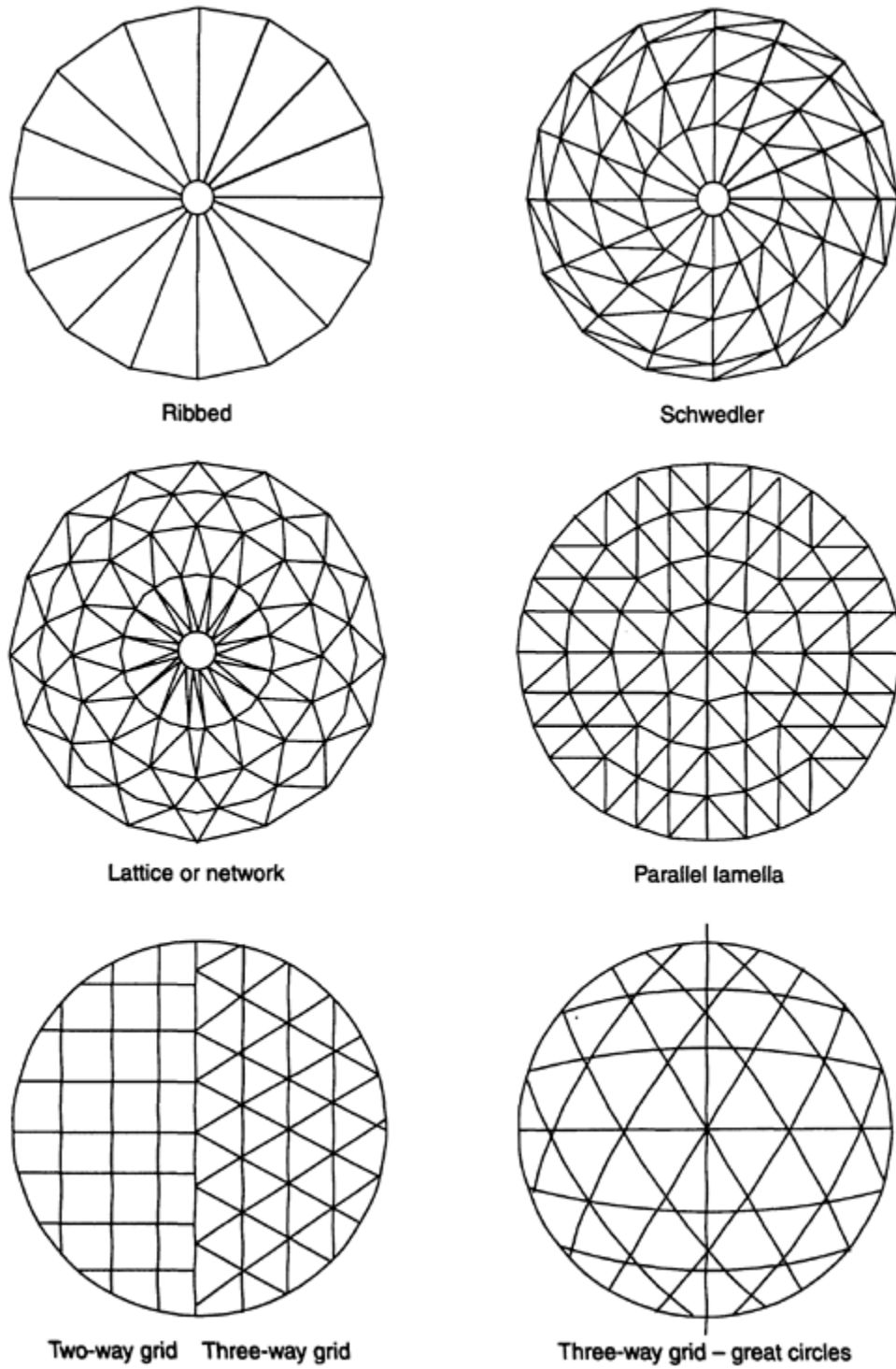

Fig. 8.11 Main types of framed domes.

### 8.5.3 Loading

(a)  
Dead load

The dead load varies from about 0.5 to say 1.2 kN/m<sup>2</sup> of the dome surface depending on the type of roof construction and cladding used and whether a ceiling is provided over the inner surface. The load acts uniformly over the roof surface area.

(b)  
*Imposed load*

The imposed load is  $0.75 \text{ kN/m}^2$  as specified in BS 6399: Part 1. This load acts on the plan area of the dome. It is necessary to consider cases where the load covers part only of the roof.

(c)  
*Wind load*

The distribution of wind pressures on domes determined by testing is given in various references (e.g. Newberry and Eaton, 1974; Makowski, 1984).

The external pressure and suction distribution depend on the ratio of dome height to diameter for a dome rising from the ground. If the dome rests on a cylindrical base, the cylinder height as well as the dome rise affects the values. In general there is a small area directly normal to the wind in pressure, while the major part of the dome is under suction. The wind pressure distributions for the two cases are shown in Figure 8.12. The distributions are simplified for use in analysis.

### 8.5.4 Analysis

The ribbed dome with ribs hinged at the base and crown and the pin-jointed Schwedler dome subjected to uniform load are statically determinate. The Schwedler dome under non-uniform load and other types of domes are highly redundant.

Shell membrane theories can be used in the analysis of Schwedler domes under uniform load. Standard matrix stiffness space frame programs can be used with accuracy to analyse stiff or double-layer domes. The behaviour of flexible domes may be markedly nonlinear and the effect of deflection must be considered. Dome stability must be investigated through nonlinear analysis. A linear analysis will be sufficiently accurate for design purposes in many cases.

### 8.5.5 Stability

Flexible domes, that is shallow or single-layer large-span domes present a stability problem. Three distinct types of buckling are discussed in Galambos (1988). These are as follows.

- (a) General buckling—a large part of the surface becomes unstable and buckles. Failures of this type have occurred where snow loads have covered part of the dome surface. Shell theory is extended to predict the critical pressure causing buckling. The critical pressure on a thin shell is

$$p_{cr} = CE(t/R)^2$$

where  $R$  is the radius,  $E$  the modulus of elasticity,  $t$  the shell thickness and  $C$  the shell coefficient.

Modified forms are given for the thickness  $t$  to allow for membrane and ribs in a braced dome. Various values are given for  $C$ .

- (b) Snap through or local buckling—one loaded node deflects or snaps through, reversing the curvature between adjacent nodes in that area. Expressions are given for checking this condition.
- (c) Member buckling—an individual member buckles as a strut under axial compression. This is considered in member design.

Dome stability can be studied using nonlinear matrix analysis.

## 8.6 SCHWEDLER DOME

### 8.6.1 Specification

A circular arts pavilion is required for a city centre cultural development. The building is to be 50 m diameter with 4 m height at the perimeter walls. It is proposed to construct a Schwedler dome, diameter 59.82 m, spherical radius 43.06 m and height

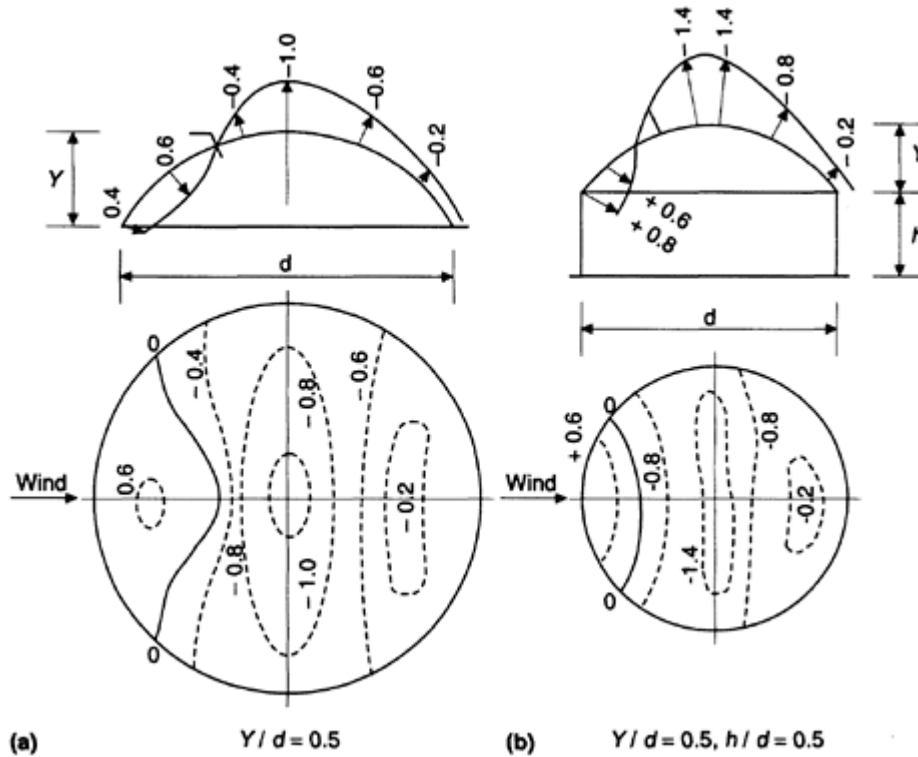

**Fig. 8.12** Pressure distribution— $C_{pe}$  values for: (a) dome rising from ground; (b) dome on cylindrical base. 12 m at the crown to meet these requirements. The dome is to have 20 radial ribs to give a 20-sided polygonal plan shape. The arrangement and framing for the dome are shown in [Figure 8.13](#).

The roofing material is to be timber supported on purlins at about 1.5 m centres spanning up the roof slope and covered with three layers of felt. The ceiling inside is plasterboard on joists. The roof dead load is 1.0 kN/m<sup>2</sup> and the imposed load is 0.75 kN/m<sup>2</sup>.

Make a preliminary design to establish sections for the ribs and rings when the dome is subjected to dead and imposed load over the whole roof. These sections would then be used as the basis for detailed computer analyses. Compare the solution from the statical analysis in the preliminary design with that from a shell membrane analysis.

### 8.6.2 Loading for statical analysis

The design loads are

Dead load on slope =  $1.4 \times 1.0 = 1.4 \text{ kN/m}^2$     Imposed load on plan =  $1.6 \times 0.75 = 1.2 \text{ kN/m}^2$     Dome steel on slope =  $1.4 \times 0.25 = 0.35 \text{ kN/m}^2$

The dimensions for calculating the rib loads are shown in [Figure 8.14](#).

The loads at the ring levels are

$F_1 = 0.35 \times 6.18 \times 8.58 / 2 = 9.3 \text{ kN}$	$F_2 = 9.3 + (1.4 \times 7.5 \times 2.06) = 53.4 \text{ kN}$	$F_3 = (1.4 \times 6.51 \times 4.27) = 77.9 \text{ kN}$	$F_4 = (1.4 \times 5.12 \times 4.5) = 62.6 \text{ kN}$	$F_5 = (1.4 \times 3.66 \times 4.68) = 45.6 \text{ kN}$	$F_6 = (1.4 \times 2.16 \times 4.8) = 27.0 \text{ kN}$	$F_7 = (1.4 \times 1.24 \times 3.41) = 11.0 \text{ kN}$	$F_8 = 2.6 \times 0.32 \times 1/2 = 0.4 \text{ kN}$
---	--	---	--	---	--	---	---

The rib loads are shown in the figure.

### 8.6.3 Statical analysis

The axial forces in rib and ring members are calculated using statics. To calculate moments the ribs are taken as continuous and the rings as simply supported members.

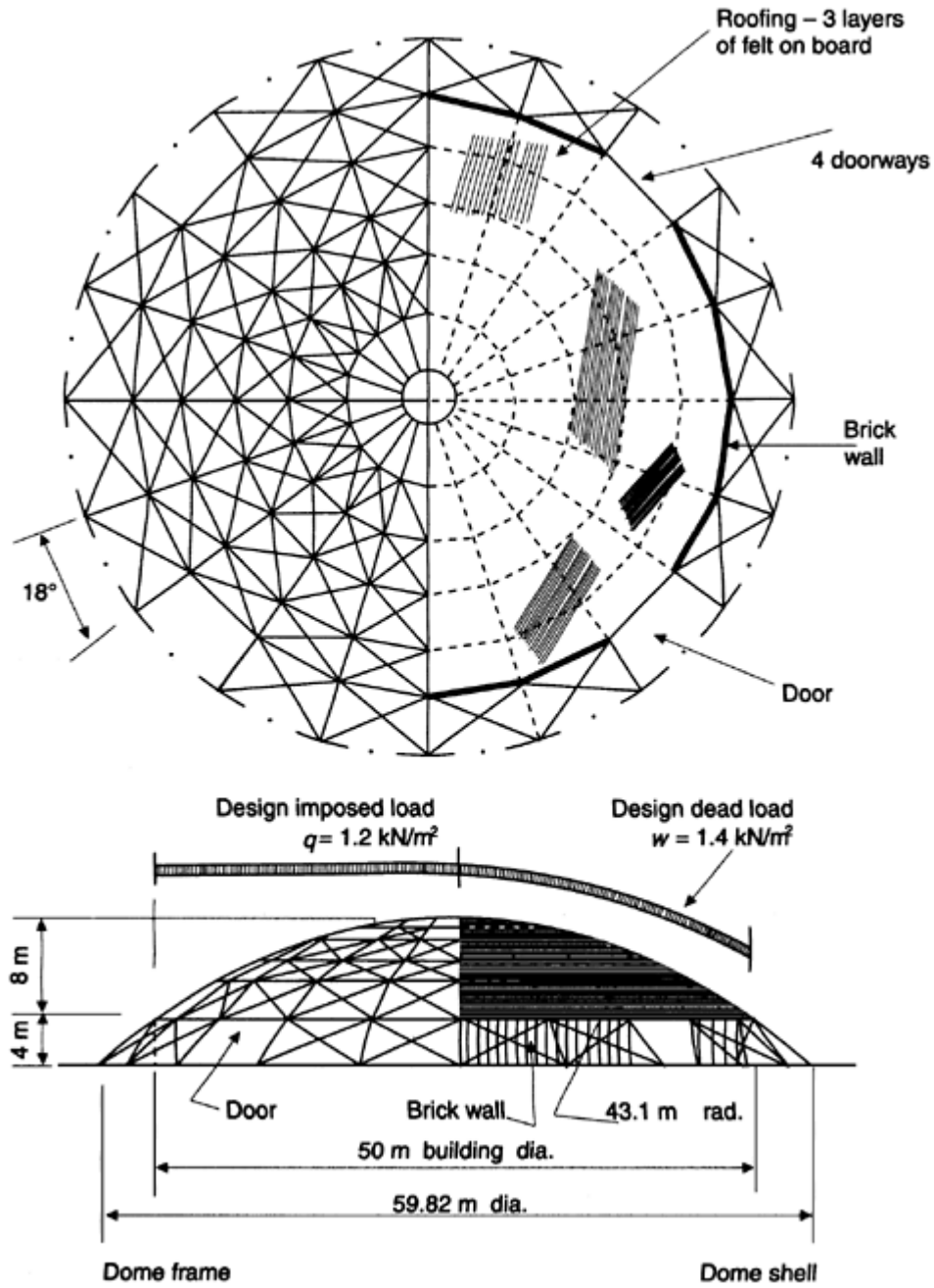

Fig. 8.13 Schwedler dome.

(a)

Rib members—axial loads [Figure 8.15(a)].

For joint 2, the total axial load above joint is 277.9 kN.

For rib 1–2:

$$[F=277.9 \times 6.24/4=434.9 \text{ kN (compression).}]$$

For joint 3, rib 2–3,  $F=421.7$  kN (compression).

For joint 4, rib 3–4,  $F=338.4$  kN (compression).

(b)

Rib members—moments.

The lateral loads on the ribs between rings 2–3 and 3–4 with four purlins are shown in Figure 8.15(b).

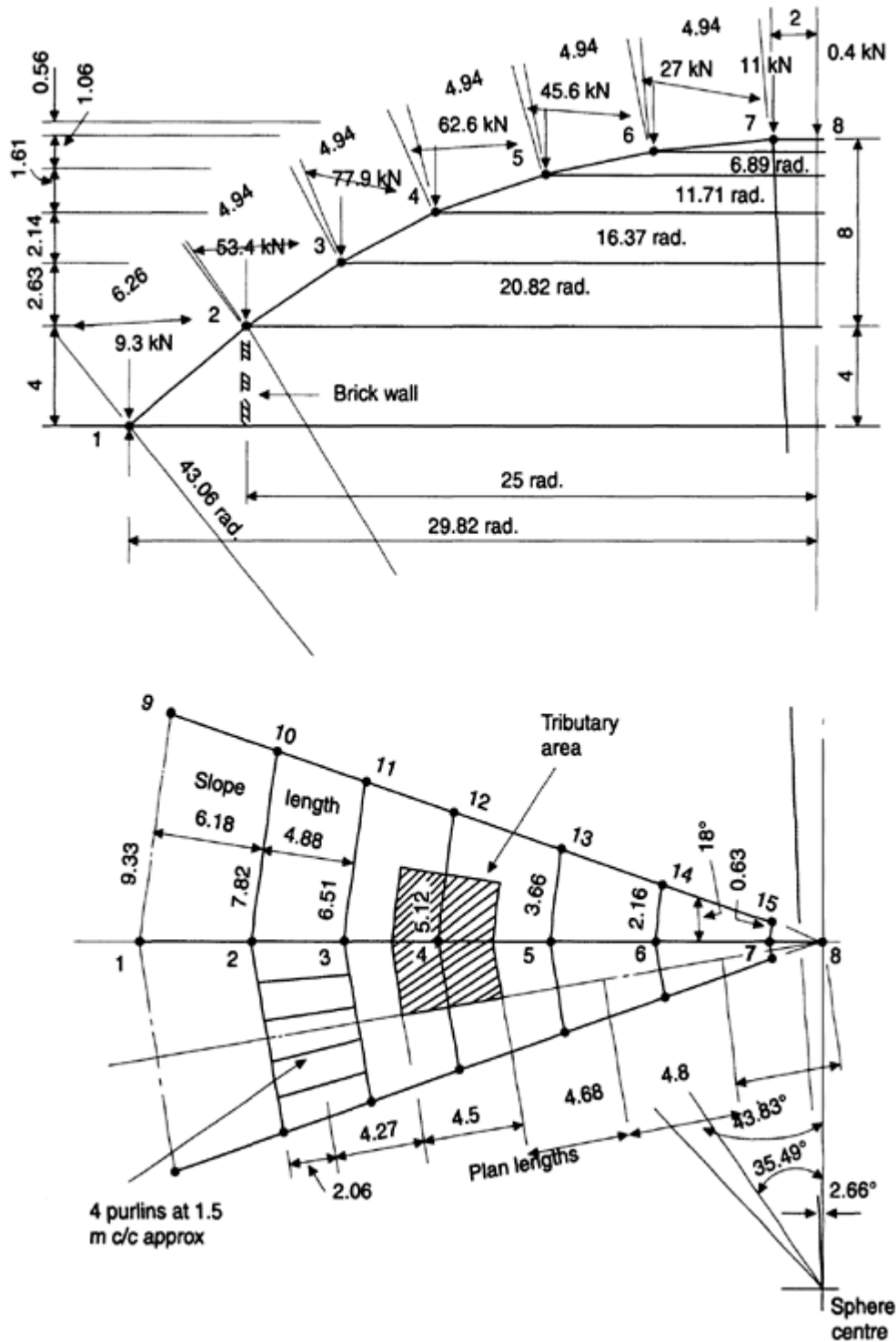

Fig. 8.14 Dome rib loads (dimensions in metres): (a) elevation; (b) plan.

The distributed loads at the joints are:

- Imposed—joint 2,  $1.2 \times 7.82 / 5 = 1.88$  kN/m; joint 3, 1.56 kN/m; joint 4, 1.23 kN/m;
- Dead—joint 2,  $1.4 \times 7.82 / 5 = 2.19$  kN/m; joint 3, 1.82 kN/m; joint 4, 1.43 kN/m.

The member loads are then calculated. For rib 2–3, the uniform load is

$$[1.56 \times 4.18] + (1.82 \times 4.94) = 15.51 \text{ kN}$$

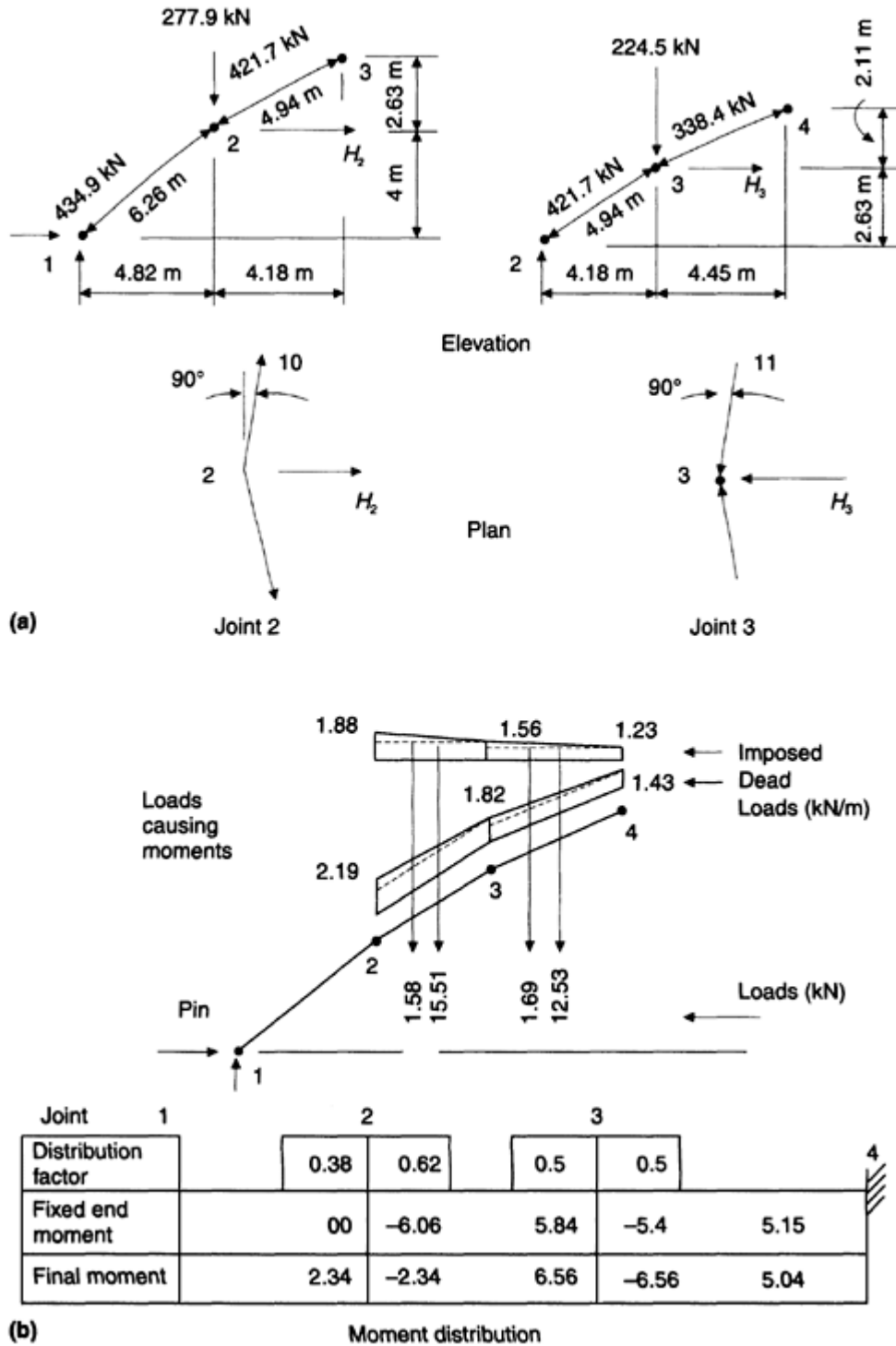

Fig. 8.15 Statical analysis: (a) axial forces in ribs; (b) moments in arch rib.

The triangular load is

$$[0.32 \times 4.18 / 2] + (0.37 \times 4.94 / 2) = 1.58 \text{ kN}$$

For rib 3–4 the uniform load is 12.53 kN and the triangular was 1.69 kN. The self-weight or member 1–2 is neglected.

The fixed end moments are

$$M_{2-3} = (15.51 \times 4.18 / 12) + (1.58 \times 4.18 / 10) = 6.06 \text{ kNm} \quad M_{3-2} = 5.4 + (1.58 \times 4.18 / 15) = 5.84 \text{ kNm} \quad M_{3-4} = 5.4 \text{ kNm}; \quad M_{4-3} = 5.15 \text{ kNm}$$

The distribution factors are, for joint 2:



$$[(DF)_{2-1}:(DF)_{2-3}=(0.75/6.25:1/4.94)/\Sigma=0.38:0.62]$$

joint 3:

$$[(DF)_{3-2}:(DF)_{3-4}=0.5:0.5]$$

The results of the moment distribution are shown in Figure 8.15(b). For joint 3,  $M=6.56$  kNm.

(c)

Ring members—axial loads (Figure 8.15(a))

For joint 2,  $\Sigma H=0$ , and

$$h_2=(434.9 \times 4.82/6.26)-(421.7 \times 4.18/4.94)=-21.9 \text{ kN}$$

For ring 2–10:

$$T=-21.9/(2 \sin 9^\circ)=-70 \text{ kN (tension)}$$

For joint 3:

$$H_3=+52 \text{ kN}$$

For ring 3–11:

$$F=166.2 \text{ kN (compression)}$$

(d)

Ring members—moments (Figure 8.14)

For joint 2, ring 2–10:

$$M=53.4 \times 7.82/8=52.2 \text{ kNm}$$

For joint 3, ring 3–11:

$$M=63.4 \text{ kNm}$$

### 8.6.4

#### Member design

(a)

Ribs

For rib 1–2:

$$F=434.9 \text{ kN (compression), } M=2.34 \text{ kNm, } L=6.26 \text{ m}$$

For rib 2–3:

$$F=421.7 \text{ kN (compression), } M=6.56 \text{ kNm, } L=4.94 \text{ m}$$

Try 150×150×6.3 SHS with  $r=5.86$  cm,  $A=36$  cm<sup>2</sup>,  $S=194$  cm<sup>3</sup>,  $p_y=355$  N/mm<sup>2</sup>

For rib 1–2:

$$\lambda=6260/58.6=106.8$$

$$P_c=153 \text{ N/mm}^2 \text{ (Table 27(a))}$$

$$P_c=153 \times 36/10=550.8 \text{ kN}$$

$$M_c=68.9 \text{ kNm}$$

Combined:

$$(434.9/550.8)+(2.34/68.9)=0.82$$

This is satisfactory. Rib 2–3 is also satisfactory.

(b)

Rings

For ring 2–10:

$$T=70 \text{ kN (tension), } M=52.2 \text{ kNm}$$

For ring 3–11:

$$F=166.2 \text{ kN (compression), } M=63.4 \text{ kNm, } L=65.1 \text{ m}$$

Try 150×150×10 SHS, with  $r=5.7$  cm,  $A=55.5$  cm<sup>2</sup>,  $S=290$  cm<sup>3</sup>.

For ring 3–11:  $\lambda=6510/57=114.2$

$$P_c=135.6 \text{ N/mm}^2 \text{ (Table 27(a))}$$

$$P_c=752.6 \text{ kN}$$

$$M_c=102.9 \text{ kNm}$$

$$\text{Combined}=0.84$$

This is satisfactory. Ring sections nearer the crown could be reduced.

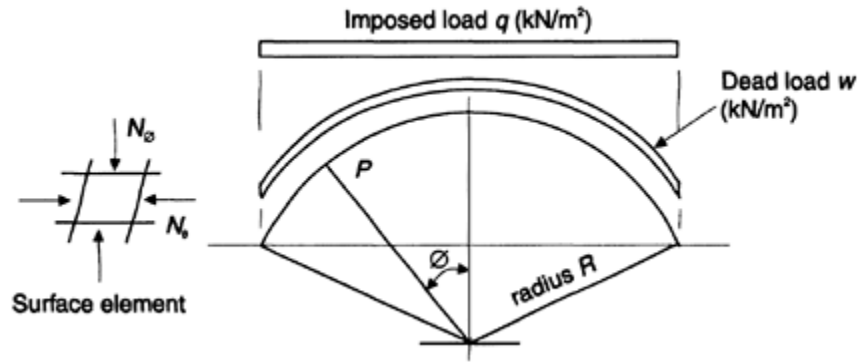

Fig. 8.16 Membrane analysis-Schwedler dome.

### 8.6.5 Membrane analysis

The forces in the members of a Schwedler dome can be determined approximately using membrane theory for spherical shells (Makowski, 1984; Schueller, 1977).

Membrane theory gives the following expressions for forces at P (Figure 8.16).

The meridional or rib force (kN/m) is

$$N_{\phi} = wR(1 + \cos \phi) + qR/2$$

The hoop or ring force is

$$N_{\theta} = wR[\cos \phi - 1/(1 + \cos \phi)] + \frac{1}{2}qR \cos 2\phi$$

where

$w$ =dead load=1.4 kN/m<sup>2</sup>;

$q$ =imposed load=1.2 kN/m<sup>2</sup>;

$R$ =shell radius=43.06 m;

$\phi$ =angle at point of force P.

These forces are calculated at joint 3 in Figure 8.16, where  $\phi=28.92^\circ$ . The ribs are spaced at 6.51 m and the rings at 4.91 m.

$$N_{\phi} = (1.4 \times 43.06)/1.88 + (1.2 \times 43.06/2) = 57.9 \text{ kN/m}$$

For rib 2–3:

$$F = 57.9 \times 6.51 = 376.9 \text{ kN}$$

This compares with average for ribs 2–3, 3–4 of 380.1 kN.

$$N_{\theta} = 1.4 \times 43.06[(0.88 - 1/1.88)] + \left(\frac{1}{2} \times 1.2 \times 43.06 \times 0.53\right) = 34.7 \text{ kN/m}$$

For ring 3–11:

$$F = 34.7 \times 4.94 = 171.4 \text{ kN}$$

This compares with 166.2 kN.

## 8.7 RETRACTABLE ROOF STADIUM

### 8.7.1 Introduction

Conventional stadium structures consist of single or multitiered grandstands grouped around an open rectangular or oval games area. Performers are in the open, while spectators may or may not be under cover. Such a state is ideal in good weather, but bad weather can cause heavy financial losses.

The normal solution is to enclose the entire area with a large fixed roof, or cable- or air-supported roof. However, a case can be made for large retractable roof structures with rigid moving parts, which combine the advantages of the traditional grandstand with the fixed roof arch or dome building. A number of such structures have already been built. An example is the National Tennis Centre in Melbourne, Australia.

Retractable roof structures pose a number of problems not encountered with normal fixed structures. Heavily loaded long-span lattice girders and cantilevers feature prominently. Loss of continuity increases weight. Further problems are discussed in [section 8.7.4](#).

### 8.7.2

#### Proposed structure

Framing plans are set out in [Figure 8.17](#) for a stadium with retractable roof to cover a games area 140 m×90 m with 40 m clear height under the roof. All-round seating on a single tier stand is provided with the whole area visible from all seats.

The grandstand area is surrounded by a 16 m wide multistorey annexe which contains administration offices, changing rooms, executive viewing boxes, gymnasias, health spas, shops etc. This structure is a normal multistorey steel-framed concrete floor slab construction.

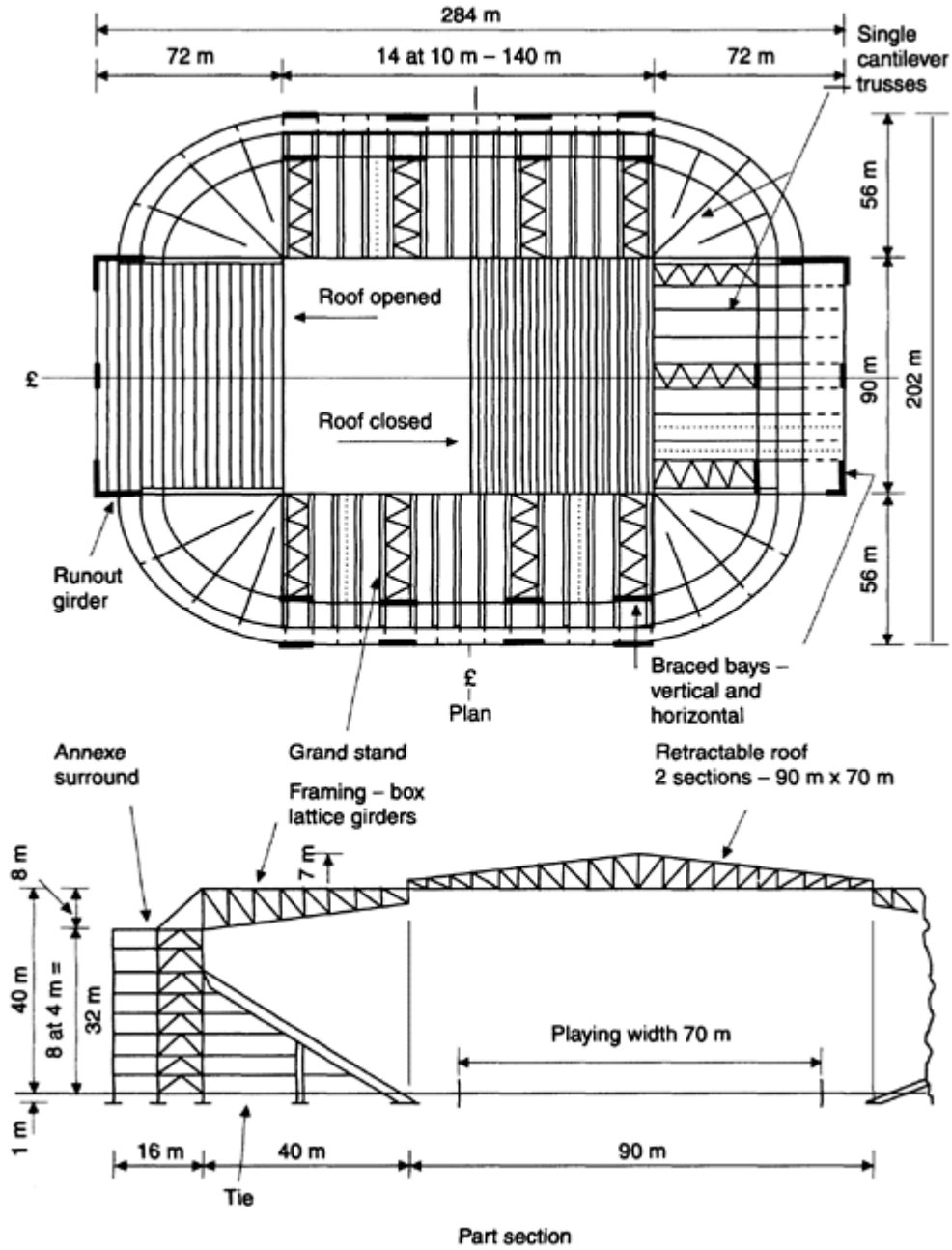

Fig. 8.17 Stadium with retractable roof.

The structure proposed consists of two movable roof sections carried on the cantilever grandstand frames, spaced at 10 m centres. The cantilevers are propped by the inclined seating girders. The preliminary sizes of the main sections for the roof and grandstand structures are given. Detail calculations are omitted.

The alternative proposal would be to adopt lattice girders 180 m long on each side to carry the roof. These girders would need to be very deep and would be very heavy.

### 8.7.3 Preliminary section sizes

The material is Grade 50 steel.

(a)  
*Movable roof (Figure 8.18(a))*

The purlins are at 2.5 m centres—use 100×5×4 RHS.

The lattice girders are at 5 m centres:

- top chord—use 180×180×10 SHS;
- bottom chord—use 150×150×8 SHS;
- web—use 120×120×6.3 SHS.

The end lattice girder is supported on wheels at 10 m centres:

- chords—use 120×120×6.3 SHS;
- web—use 120×120×5 SHS.

(b)  
*Runway girder (Figure 8.18(b))*

This is a plate girder 1400mm×500mm, with flanges 40 mm thick and web 15 mm thick.

(c)  
*Grandstand roof cantilever (Figure 8.18b))*

- Diagonal 1–3—use 350×350×16 SHS;
- top chord 3–5—use 300×300×10 SHS;
- bottom chord 2–4—use 300×300×12.5 SHS.

(d)  
*Seating girder (Figure 8.18(b))*

This is a box girder 1500 mm deep×600 mm wide with flanges 40 mm thick and webs 10 mm thick.

(e)  
*Lattice box column (Figure 8.18(b))*

There are four column legs at the base—use 400×450×16 SHS.

(f)  
*Column tie (Figure 8.18(b))*

Use two 250×250×20mm plates.

#### 8.7.4 Problems in design and operation

The following problems must be given consideration.

1. Deflections at the ends of the cantilever roof must be calculated. Differential deflection must not be excessive, but precise limits acceptable would need to be determined from mechanical engineering criteria. The factored design load for the retractable roof is 1.9 kN/m<sup>2</sup> while the unfactored dead load is 0.5 kN/m<sup>2</sup>. The latter load would apply when moving the roof.
2. The retractable roof must be tied down against wind uplift and could not be moved under high wind speeds. Wind tunnel tests would be required to determine forces for the open roof state.
3. Temperature effects create problems. Expansion away from the centre line on 100 m width is 60 mm for 50°C temperature change. The roof could be jacked to rest on transverse rollers when it is in the open or closed position. Note also the need to secure against uplift.

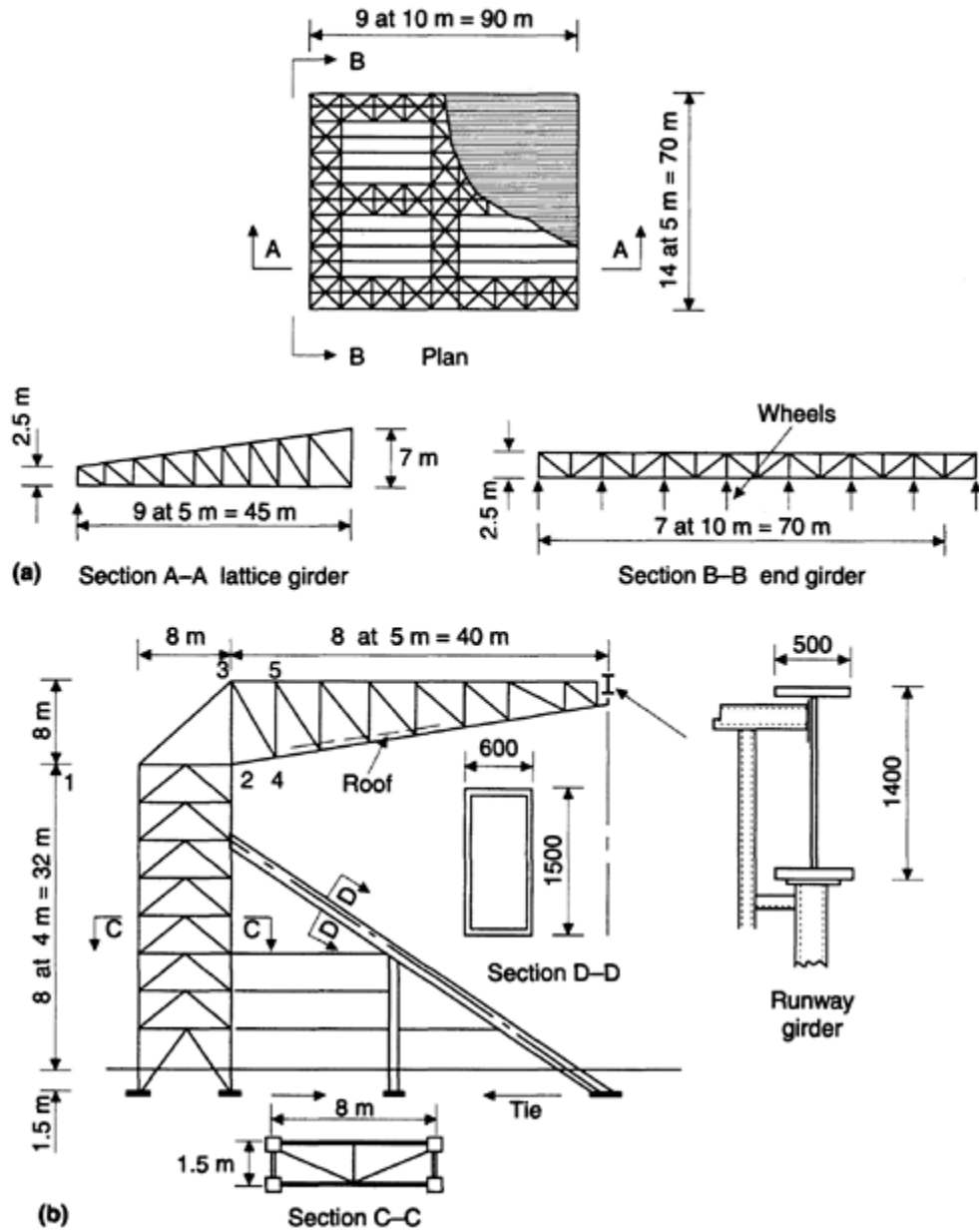

Fig. 8.18 Dimensions for: (a) retractable roof unit; (b) grandstand support structure.

4. Problems could arise with tracking and possible jamming. Some measure of steering adjustment to the wheel bogies may be necessary. Model studies could be made.
5. The movable roof should be made as light as possible. Some alternative designs could be:

- tied barrel vault construction;
- design using structural aluminium;
- air-inflated, internally framed pneumatic roof structure.

It is considered that the above problems could be successfully overcome.

# Bibliography

## BRITISH STANDARDS

- BS 449: Part 2 (1969) *The use of structural steel in building.*  
BS 476: Part 3, Part 8 (1968–75) *Fire tests on building materials and structures.*  
BS 5493 (1977) *Protective Coatings of Iron and Steel Structures Against Corrosion.*  
BS 5950 *Structural Use of Steelwork in Building.*  
Part 1 (1990) *Code of practice for design in simple and continuous construction: Hot rolled sections.*  
Part 3 (1990) *Code of practice for design of simple and continuous composite beams.*  
Part 4 (1994) *Code of practice for design of composite slabs with profiled steel sheeting.*  
Part 6 *Code of practice for design of light gauge sheeting, decking and cladding*  
Part 8 (1990) *Code of practice for fire resistant design.*  
BS 6399 *Loading for Buildings.*  
Part 1 (1984) *Code of practice for dead and imposed loads.*  
Part 2 (1995) *Code of practice for wind loads.*  
CP3: Chapter V, Part 2 (1972). *Loading. Wind Loads.*

## DRAFT STANDARD FOR DEVELOPMENT

- Eurocode 3 DD ENV 1993–1–1: 1992 *Design of Steel Structures, Part 1.1 General rules and rules for buildings.*

## BUILDING REGULATIONS

- Building Regulations.* Part A, *Structure of the Building Regulations*, Part B, *Fire Safety*, HMSO, London.

## REFERENCES AND FURTHER READING

- Bowles, J.E. (1988) *Foundation Analysis and Design*, McGraw Hill Book Company, New York.  
Coates, R.C, Coutie, M.G. and Kong, F.K. (1988) *Structural Analysis*, Van Nostrand Reinhold UK, Wokingham.  
Council on Tall Buildings (1985) *Planning and Design of Tall Buildings*, 5 vols, American Society of Civil Engineers.  
Galambos, T.V. (ed.) (1988) *Guide to Stability Design Criteria for Metal Structures*, 4th edn, John Wiley, New York.  
Ghali, A. and Neville, A.M. (1989) *Structural Analysis*, 3rd edn, Chapman & Hall, London.  
Dowling, P.J., Knowles, P.R. and Owens, G.W. (eds) (1988) *Structural Steel Design*, Butterworths, London.  
Hart, F., Henn, W. and Sontag, H. (1978) *Multistorey Buildings in Steel*, Granada Publishing, London.  
Horne, M.R. (1971) *Plastic Theory of Structures*, Nelson, London.  
Horne, M.R. and Morris, L.J. (1981) *Plastic Design of Low Rise Frames*, Collins, London.  
Johnson B.G (ed.) (1976) *Guide to Stability, Design Criteria for Metal Structures*, 3rd edn, John Wiley, New York.  
Kirby, P.A. and Nethercot, D.A. (1979) *Design for Structural Stability*, Collins, London.  
Lee, G.C., Ketter, R.L. and Hsu, T.L. (1981) *The Design of Single Storey Rigid Frames*, Metal Manufacturers Association, Cleveland Ohio.  
Leonard, J.W. (1988) *Tension Structures—Behaviour and Analyses*, McGraw Book Company, New York.  
Lothers, J.E. (1960) *Advanced Design in Structural Steel*, Prentice Hall, Englewood Cliffs, NJ.  
MacGinley, T.J. and Ang, P.T.C. (1992) *Structural Steelwork—Design to Limit State Theory*, Butterworths/Heinemann, Oxford.  
Makowski Z.S. (ed.) (1984) *Analysis, Design and Construction of Braced Domes*, Granada Technical Books, London.  
Morris, L.J and Plum D.L. (1988) *Structural Steelwork Design*, Nichols Publishing, New York.  
Narayanan, R. (ed.) (1985) *Steel Framed Structures—Strength and Stability*, Elsevier Applied Science Publishers, London and New York.  
Newberry, C.W. and Eaton, K.J. (1974) *Wind Loading Handbook*, Building Research Establishment, HMSO, London.  
Orton, A. (1988) *The Way We Build Now—Form, Scale and Technique*, Van Nostrand Reinhold UK, Wokingham.  
Pask, J.W. (1982) *Manual on Connections for Beam and Column Construction*, British Constructional Steelwork Association, London.  
Schueller, W. (1977) *High-rise Building Structures*, John Wiley, New York.  
Schueller, W. (1983) *Horizontal-span Building Structures*, John Wiley, New York.

- Steel Designers Manual*, 4th edn (1986) BSP Professional Books, Oxford.  
*Steel Designers Manual*, 5th edn (1994) Blackwell Scientific Publications, Oxford.  
 Taranath, B.S. (1988) *Structural Analysis and Design of Tall Buildings*, McGraw Hill, New York.  
 Timoshenko, S.P. and Gere, J.M. (1961) *Theory of Elastic Stability*, 2nd edn, McGraw Hill, New York.  
 Trahair, N.S. and Bradford, M.A. (1988) *The Behaviour and Design of Steel Structures*, Chapman & Hall, London.  
 Yam, L.C.P. (1981) *Design of Composite Steel—Concrete Structures*, Surrey University Press, London.

#### TECHNICAL PAPERS—JOURNALS AND CONFERENCES

- Bucholdt, H.A. (1984) Cable roofs, in *Symposium—Long Span Roofs*, Institution of Structural Engineers.  
 Davies, J.M. (1990) Inplane stability of portal frames. *The Structural Engineer*, **68**(8).  
 Dickie, J.F. (1984) Domes and Vaults, in *Symposium—Long Span Roofs*, Institution of Structural Engineers .  
 Dowling, P.J., Harding, J.E. and Bjorhovde, R. (ed.) (1987) *Journal of Constructional Steel Research—Joint Flexibility in Steel Frames*, Elsevier Applied Science, London and New York.  
 Fraser, D.J. (1980) Effective lengths in gable frames, sway not prevented. *Civil Engineering Transactions, Institution of Engineers Australia*, **CE22**(3)  
 Jenkins, W.M., Tong, C.S. and Prescott, A.T. (1986) Moment transmitting endplate connections in steel construction and a proposed basis for flush endplate design. *The Structural Engineer*, **64**(5)  
 Khan, F.R. and Amin, N.R. (1973) Analysis and design of framed tube structures for tall concrete buildings. *The Structural Engineer*, **51**(3).  
 Skilling, J.B. (1988) Advances in high rise building. Annual lecture. *Singapore Structural Steel Society*, 3(3).  
 Weller, A.D. (1993) An introduction to EC3. *The Structural Engineer*, **71**(18).

#### HANDBOOKS AND TECHNICAL LITERATURE

- British Steel Corporation Tubes Division, Corby (1984) Construction with hollow sections .  
 British Steel Corporation Tubes Division, Corby. Nodus Space Frame Grids Part 1 —Design and construction.  
 Conder International Ltd, Winchester. Steel framed buildings.  
 Constradd. Profiled steel cladding and decking for commercial and industrial buildings.  
 Constradd: Elliott, D.A. (1983) Fire protection for structural steel in buildings.  
 Eastern Partek, Singapore. Hollow-core prestressed slabs. Section properties, load/span chart.  
 European Convention for Constructional Steelwork, Brussels (1991) Essentials of Eurocode 3, Design manual for steel structures in building.  
 John Lysaght, Australia. Galvanised 3W and 2W steel decking.  
 Mero space frames. Mero-Raumstruktur. GmbH & Co, Wurzburg, Germany.  
 Nippon Steel Corporation, Tokyo (1986) NS space truss system. Design manual.  
 Otis lifts, Newcastle-upon-Tyne. Passenger lift planning guide.  
 Precision Metal Forming Limited, Cheltenham (1993) P.M.F. composite floor decking systems.  
 Space Deck Limited, Somerset. Space frame grids. Part 1. Design and Construction. Part 2. Analysis.  
 Steel Construction Institute, Ascot (1987) Steelwork design guide to BS 5950: Part 1. Vol. 1 Section properties, member capacities; Vol. 2 Worked examples.  
 Trade ARBED, Luxembourg. Structural shapes. Histar rolled section.  
 Ward Building Components Ltd, Matton (1986) Multibeam purlin and cladding rail systems .



# Index

- Air conditioning, tall buildings 172
- Aluminium coatings 41
- Arches
  - lattice 96–100
  - stability 95
  - two-pinned *see* Two-pinned arches
- Architects 7
  - multidisciplinary approach 9–10
- Arrangement drawings 20
- Axial load, member design 56
  
- Baseplates 87
  - centre columns 108
- Beam-columns, design 61–2
- Beams
  - castellated 145
  - composite *see* Composite beams
  - continuous 51
  - deflection limits 38
  - design 57–60, 109, 112–13
  - elastic analysis 149–51
  - end plates 117
  - loads 188–91
  - plastic design 118
- Bending
  - lattice arches 98
  - member design 56
- Bills of quantities 21–2
- Bolts 23
  - design 115–16, 139–41
  - eaves 84–5
  - semirigid design 128–30, 139–41
- Bottom flanges, stability 151
- Braced structures, tall buildings 173–4
- Bracings 184
- Brickwork, fire protection 44
- British Standards 21
  - BS 449 25
  - BS 5493 41–2
  - BS 5950 15
  - BS 5950: Part 1 25, 28, 29–30
  - BS 5950: Part 3 148
  - BS 5950: Part 4 147
  - BS 5950: Part 6 147
  - BS 5950: Part 8 45
  - BS 5950
    - brittle fracture 41
    - Clause 2.1.2.4 127
    - Clause 3.3.3 57
    - Clause 4.8.3.3 118
    - Clause 5.7.2 118
  - design methods 32–5
  - design strengths 31
  - fatigue failure 38–40
  - fire protection 45
  - limit states 29–30
  - loads 30–1
  - Section 4.3 58
  - serviceability 37–8
  - stability design 35–6
  - structural integrity 36–7
  - Table 24 57
  - BS 6394: Part 1 185
  - BS 6399 30
  - BS 6399: Part 1 30, 60
  - BS 6399: Part 2 30, 196
  - BS 8110 104
  - CP 3 Chapter V, Part 2 30
- British Steel Corporation 218
- Brittle fracture 40–1
- Buckling, domes 230–1
- Building heights 171
- Building materials *see* Structural materials
- Building Regulations 1991 36, 44–5
- Butt welds, failure 39
  
- Cable-supported roof structures 5
- Cantilever construction 16
  - floors 178
- Cantilever method, analysis of multistorey buildings 55–6
- Cavity walls 183
- Cladding, domes 229
- Clients, building construction 7
- Collapse, progressive 36
- Columns
  - centre 124–7, 135–9
    - baseplates 108
    - design 107–8, 114–15
  - dead loads 102
  - deflection at eaves 87–8
  - deflection limits 38
  - design 57, 113–15
  - external 121–4, 133–5
  - flange plates 117–18
  - loadbearing 2
  - multistorey buildings 49
  - outer, design 105–7, 113–14
  - perimeter 191–4

- plastic design 118
- restraint force 78–9, 213, 216
- spacing 13, 14–15
- stiffeners 87
- subframes 120
- tall buildings 183
- tie-stayed roofs 209–10
- UB flanges 86
- web shear 86
- Comité Européen du Béton 28
- Comparative design 11–16
- Composite beams
  - continuous 156–7
  - deflection 153, 155–6, 169–70
  - design 148–53
  - floor loads 157–8
  - hogging moment 164–6
  - sagging moment 162–4
  - shear connectors 166–7
  - simply supported 153–6
- Composite floors 145–8, 183
- Composite structures, tall buildings 176–9
- Compression, lattice arches 98
- Computer analysis
  - braced frames 109
  - space decks 222–5
- Conceptual design 9–11
- Concrete
  - cast-*in situ* 145, 183
  - fire protection 43–4
  - foundations 7
  - precast 145
  - shear walls 2, 15
  - structural 28, 172
- Concrete core structures 178–9
- Connections, design 32, 35
- Connectors, shear 151–2, 154
- Construction, composite beams 149
- Consultants, building construction 7
- Continuous beams 51
- Contractors, building 7
- Core walls, braced 194–6
- Corrosion protection 41–2
- Costs
  - comparative 11
  - fabrication 22
- Cranes 23
  - dynamic loads 30
- Curtain walls 183
- Damage
  - accidental, design for 36–7
  - localization 37
- Dead loads 30
  - composite beams 158
  - domes 229
  - eaves joint bolts 84–5
  - estimation 48–9
  - multistorey buildings 102, 104, 185, 188
  - pinned base portals 69
  - tie-stayed roofs 213, 216
  - two-pinned arches 91
- Decks, composite 147–8
- Deflection
  - composite beams 153, 155–6, 169–70
  - limits 38
- Design
  - alternatives 48
  - comparison 11–16
  - conceptual 9–11
  - from experience 25
  - preliminary *see* Preliminary design
  - steel structures, methods 32–5
- Design strengths, structural steels 31
- Detail drawings 20
- Direct bearing foundations 5–6
- Domes 5, 203
  - construction 229
  - loading 229–30
  - ribbed, design 63
  - stability 230–1
  - types 226–9
- Drawings 20
- Dynamic loads 30
- Effective modular ratio 159
- Effective section 148–9
- Elastic analysis 34, 51
  - beams 149–51
  - braced, multi-storey buildings 109–18
  - composite beams 160–1
  - frame design 130
  - multistorey frames 53
  - portal design 52
  - tapered member portal design 88–90
- Elastic theory 25–7
- Element design 56–62
- Erection
  - effects on design 22–3
  - specifications 20
- Eurocode 3, 25, 29, 32, 34, 127–8
- Fabrication 22
  - specifications 20
- Fatigue, failure 38–40
- Fillet-welds, failure 39
- Finite element analysis 18
- Fire engineering 44
- Fire protection 15, 42–5, 172
- Fire Research Station 43
- Fire resistance, steelwork 42–3
- Fixed end moments, frame analysis 131
- Floor beams 183
  - design 105, 112–13, 120–1, 133, 188–90
- Floor loads, composite beams 157–8
- Floors
  - cantilevered 178
  - composite 145–8
  - multistorey buildings 15
  - tall buildings 183
  - types 145

- Floor systems
  - analysis 49
  - framing 143–5
- Footings, foundations 5–6
- Foundations 5–7
  - multistorey buildings 15, 201
  - tall buildings 173
- Frame design
  - multistorey buildings 53–6, 120–7, 132–41
  - semirigid design 132–41
- Framed structures 3, 5
  - rigid, tall buildings 174–6
- Frames, plastic design 28
- Framing
  - domes 229
  - floor systems 143–5
  - multistorey structures 14–15
  - pinned-base portals 67–9
- Fuller, Buckminster 227
  
- Galvanizing 41
- Geodesic domes 227, 229
- Girders
  - belt truss 176
  - lattice 16, 49–50, 61, 145, 176, 206
  - outrigger 176
  - plate 39, 60–1
  - runway 241
  - seating 241
  - spine 207–9
  - stub 145
- Grandstands 16
- Grid domes 227
  
- Hangers 184
- Haunches 80–2, 87
- Heating, tall buildings 172
- Hinges
  - capacity at 78
  - plastic 118
  - rafters 52, 74–7, 82–3
- Hogging moment, composite beams 164–6
- Hot-Rolled steels 3
  
- Idealization, structures 17
- Imposed loads 30
  - composite beams 158
  - domes 230
  - eaves joint bolts 84–5
  - multistorey buildings 104, 185, 188
  - pinned base portals 70
  - tie-stayed roofs 213, 216
  - two-pinned arches 91
- Innovation, structural engineering 10
- Intumescent coatings 44
  
- Joints
  - design 35, 108, 115–18, 139–41
  - dome systems 229
  - portals 84–7
  - semirigid design 128–30
  - site 23
  - space decks 218, 222
  - stiffness 33
  - welded, failure 38–9
  
- Khan, Fazlur 180, 182
  
- Lamella domes 227
- Lattice arches 96–100
- Lattice domes 227
- Lattice girders 16, 49–50, 145
  - design 61
  - roofs 206
  - staggered 176
- Lifts 172
- Liftshafts, stability 15
- Limit states
  - design basis 29–30
  - theory 28–9
- Loading
  - composite beams 153–4
  - domes 229–30
  - elastic behaviour 25–6
  - estimation 48–9
  - multistorey buildings 102–4, 119–20
  - multistorey frames 53–4
  - pinned-base portals 69–74
  - plastic theory 28
  - Schwedler domes 233
  - space decks 224–5
  - tests 34
  - transfer 16–17
  - two-pinned arches 91–3
- Loading structures 3–4
- Load paths 16–17
- Load patterns, multistorey buildings 119–20
- Longitudinal shear 152–3, 155, 167–9
- Longitudinal wind load 72–3
  
- Masonry 2
- Materials, quantities 21–2
- Mathematical methods, design optimization 11–12
- Members
  - beams, design 151
  - design 34–5
  - space decks 222, 225–6
- Membrane analysis, Schwedler domes 238–9
- Mero Joint System 218, 229
- Metal spraying 41
- Mill scale 41
- Mobile cranes 23
- Modelling
  - preliminary design 48
  - structures 17–19
- Moment capacity, composite sections 149
- Moment coefficients, beam analysis 160
- Moment distribution factors, frame analysis 130–2
- Multistorey buildings 5
  - alternative designs 48

- braced rigid elastic design 109–18
- braced rigid plastic design 118–27
- columns 49
- design comparison 14–16
- frame design 53–6, 120–7, 132–41
- loads 102–4, 119–20, 185–91
- semirigid design *see* Semirigid design
- simple design 104–8
- specification 101–2, 185
- wind loads 196–200
- see also* Tall buildings
  
- Negative moments, longitudinal shear 169
- Network domes 227
- Nippon Steel Corporation NS Space Truss System 218, 229
- Nodus System 218
  
- Occupancy, tall buildings 171–2
- Optimization, design 11–12
- Overturning, stability 35
  
- Paints, steel 41–2
- Partial safety factors 31–2
- Piled foundations 6–7
- Pinned-base portals
  - design checks 77–83
  - design load 73–4
  - loading 69–74
  - pitched roof 51–3
  - plastic design 74–7
  - serviceability check 87–8
  - specification and framing 67–9
- Pitched roofs, trusses 49
- Planes, idealized structures 17
- Planning, structural engineering 10–11
- Plans, drawings 20
- Plastic analysis 34, 51
  - design checks 77–83
  - frame design 130
  - multistorey buildings 118–27
  - multistorey frames 53
  - pinned-base portals 74–7
  - portal design 51–2, 62, 63–5
- Plastic theory 28
- Plate girders
  - design 60–1
  - weld failure 39
- Plate thickness, brittle fracture 40
- Pneumatic structures 4
- Portal frames, members, design 62
- Portal method, analysis of multistorey buildings 54–5
- Portals
  - built-up tapered member 88–90
  - pinned-base, pitched roof 51–3
  - pinned-base *see* Pinned-base portals
  - plastic design 28, 62
  - three-pinned 51
  - two-pinned, plastic design 63–5
- Positive moments, longitudinal shear 167–8
- Preliminary design 47–9
  - analysis 49–56
  - space decks 219–26
  - tie-stayed roofs 206–13
- Production processes, steels 3
- Progressive collapse 36
- Pyramid unit, space decks 218
  
- Quantities, materials 21–2
  
- Rafters
  - endplates 86
  - haunches 80–2
  - hinges 52, 74–7, 82–3
  - near ridges 82–3
  - wind loads 76–7
  - wind uplift 83–4
- Ribbed domes 227
  - design 63
- Rib members, Schwedler domes 233–6, 237
- Ridge joints 87
- Rigid design 32
- Rigid frame structures, tall buildings 174–6
- Ring members, Schwedler domes 236–8
- Robustness, buildings 36
- Roof beams
  - design 104, 109, 120, 133
  - loads 191
- Roofs
  - cantilever 241
  - lattice girders 206
  - pitched, pinned-base portals 51–3
  - retractable 205, 239–43
  - slopes 13
  - suspended 16
  - tall buildings 183
  - tie-stayed 206–16
  - trusses 49–50
  - two-way spanning 216–17
- Roof structures, cable-supported 5
  
- Safety factors, partial 31–2
- Sagging moment, composite beams 162–4
- Schwedler domes 5, 227, 231–9
- Seismic loads 31
- Semirigid design 33–4
  - code requirements 127–8
  - frame analysis 130–2
  - frame design 132–41
  - joint types 128–30
- Serviceability, limit states 37–8
- Shear
  - composite beams 154
  - longitudinal 152–3, 155, 167–9
  - member design 56
  - vertical 151
  - webs, columns 86, 123
- Shear connectors 151–2
  - composite beams 154, 166–7
- Shear resistance 152
- Shear walls 2, 15, 176–8, 183

- Shell structures 4
- Simple design 32
- Single-storey buildings 67
  - alternative designs 48
  - design comparison 13
- Site joints 23
- Sites, tall buildings 173
- Slabs
  - design 104
  - effective breadth 148–9
  - flooring 145
- Space decks 5, 216–19
  - preliminary design 219–26
  - two-way spanning 203, 216–17
- Space structures 5
- Specifications 20–1
- Spine girders, analysis 207–9
- Stability
  - domes 230–1
  - limit state 35–6
  - multistorey buildings 15, 200–1
  - tie-stayed roofs 213–16
  - two-pinned arches 95
- Stadiums, retractable roofs 205, 239–43
- Stairs 172
- Statical analysis, Schwedler domes 233–7
- Statically determinate structures 49–51
- Statically indeterminate structures 52–6
- Statics 34
- Steels
  - structural *see* Structural steels
  - weathering 42
- Steel structures
  - alternative designs 12–13
  - design methods 32–5
  - structural integrity 36–7
  - types 5
- Steelwork
  - drawings 20
  - fire resistance 42–3
  - specifications 20–1
- Stiffeners, columns 87
- Stiffness, frame analysis 132
- Stress, brittle fracture 40
- Stresses, elastic behaviour 26–7
- Structural design 9
  - theories 25–9
- Structural engineering 7–9
  - conceptual design 9–11
- Structural materials 2–3
- Structural steels 2–3
  - design strengths 31
- Structures
  - analysis 49–56
  - idealization 17
  - modelling 17–19
  - special purpose 16
  - types 3–5
  - use 1–2
- Struts, design 57
- Stub girders 145
- Surface preparation, steel 41
- Suspended roofs 16
- Suspended structures, tall buildings 180
- Sway stability 35, 37
  - portals 77–8
- SWMB structures 182
- Tall buildings 171–2
  - composite structures 176–9
  - construction details 182–4
  - structural design 172–3
  - structural systems 173–82
  - tube construction 15
  - see also* Multistorey buildings
- Temperature, brittle fracture 40
- Tension structures 4, 5
- Three-pinned portals 51
- Ties
  - buildings 36, 37
  - design 57
  - roofs 211–13
- Tower cranes 23
- Towers 5
- Trade-ARBED 3, 183
- Transport, effects on design 22–3
- Transverse wind load 71–2, 83
- Trusses 49–50
- Tube structures, tall buildings 15, 180–2
- Two-pinned arches
  - design 93–6
  - loading 91–3
  - specification 91
- Two-pinned portals, plastic design 63–5
- Universal beams, design 57–60
- Vermiculite, casing, fire protection 44
- Vertical shear 151
- Vibration 38
- Wall-floor loads 104
- Walls
  - core, braced 194–6
  - dead loads 102, 104
  - loadbearing 2
  - shear 2, 176–8
  - steel-framed buildings 183
- Weldability, steels 3
- Welded joints, failure 38–9
- Welding 23
- Wide-span buildings 203–5
- Wind loads 30, 38, 49, 74
  - domes 230
  - multistorey buildings 196–200
  - pinned-base portals 70–3
  - rafters 76–7, 83–4
  - tie-stayed roofs 216
  - two-pinned arches 91, 93
- Wind speeds 71, 197

Zinc coatings 41